

THE MILLENNIUM COUPLING COMPANY
MCC GERMANY

2025

HOSE COUPLINGS · INDUSTRIAL HOSES · ACCESSORIES

WE DO IT UNDER PRESSURE



E-Mail: info@mcc-germany.com
Telefon: +49(0)2241/932580
Adresse: Langbaughstr. 5; 53842 Troisdorf

www.mcc-germany.com



THE MILLENNIUM COUPLING COMPANY
MCC GERMANY



DOWNLOAD PDF VERSION

2025

HOSE COUPLINGS · INDUSTRIAL HOSES · ACCESSORIES



Schnellkupplungen	13
Tankwagenarmaturen EN 14420 - 6	14
API Tankwagenarmaturen	28
Trockenkupplungen	34
Hebelarmaturen - System Kamlok - EN 14420-7/MIL	38
Schneekanonen - Kupplungen	98
Symmetrische Kupplungen - System Guillemin	100
DSP Kupplungen	121
Storz Kupplungen	124
Klauenkupplungen n. DIN3489 + US-Ausführung	146
Pressluftarmaturen - Express	158
Sandstrahlarmaturen	162
Wasserschlaucharmaturen 1/3+2/3 Verschraubungen / Sauger	164
Barcelona Armaturen	179
IBC-Armaturen	181
Composite	197
PFA Armaturen	207
Armaturen – Lebensmittel	225
Clamp Kupplungen	226
Milchrohrverschraubungen n. DIN11851	242
SMS Kupplungen 1145	276
Macon Kupplungen	290
Schlauchverschraubung	299
Schalenverschraubungen n. EN 14420-2	300
Kombination Nippel KC	318
Dampfschlaucharmaturen	325
Presshülsen & Klemmschalen	335
Klemmschalen EN 14420-3	336
Presshülsen	346
Jubilee - Schlauchklemmen & Zubehör	356
MCC Schellen	361
Flanscharmaturen	367
Fittings & Zubehör	373
Fittings	374
Kugelhähne & Ventile	386
Prallschutz	390
Wassersparventile	394
Dichtungen	396
Schlauchsicherungskabel-Whipchecks & Zubehör	426
PT Couplings - Produkte	432
Feuerschutz-Schläuche	437
Silikonschläuche	451
Arbeitsschutz	474



Quick Couplings	13
Tankwagon EN 14420 - 6	14
API Couplings	28
Dry-break Couplings	34
Cam & Groove Couplings	38
Snow Cannon Cam & Groove	98
Symmetric Coupling - System Guillemin	100
DSP Couplings	121
Storz Couplings	124
European Type Compressor Couplings + US -Type	146
Compressed Air Fittings - Express	158
Sandblasting Couplings	162
Water Hose Fittings + 1/3 + 2/3 Brass Garden / Fittings	164
Barcelona Couplings	179
IBC-Couplings	181
Composite	197
PFA Couplings	207
Hygenic Fittings – Food Industry	225
Clamp Couplings	226
Hygenic fittings DIN 11851	242
Hygenic fittings SMS Couplings 1145	276
Macon Couplings	290
Hose Coupling	299
Hose Shanks for safety clamps EN 14420-2	300
Combination Nipples KC	318
Steam hose Couplings	325
Crimping ferrules and hose clamps	335
Safety Clamps EN 14420-3	336
Crimping Ferrules	346
Jubilee – Hose Clips and Accessories	356
Clamps / Clips	361
Flanges	367
Fittings & Accessories	373
Fittings	374
Ball Valves & Valves	386
Protection Ring	390
Washdown Guns	394
Dichtungen	396
Whipchecks & Accessories	426
PT Couplings - Products	432
Fire Protection Hoses	437
Silicone Hoses	451
Personal Protection	474



Raccord à Accouplement Rapide 13

Tankwagen EN 14420-6	14
API	28
Raccord auto-obturant	34
Raccords à Cames - EN 14420-7/MIL	38
Camlock pour neige	98
Raccords Symétriques Guillemain	100
DSP	121
Storz	124
Européens DIN3489 + Américains DIN3489 + US	146
Express	158
Raccords de Sablage	162
Raccord pour tuyau d'eau + 1/3 + 2/3 Raccordement vissé	164
Raccords Barcelona	179

IBC 181

Douilles Helicoïdales pour Tuyaux Composite 197

PFA - Revêtu de PFA 207

Raccords Alimentaires 225

Raccords Clamp	226
Raccords DIN11851	242
Raccords SMS 1145	276
Raccords Macon	290

Raccords Filetés 299

Douilles Lisses EN 14420-2	300
Raccords Type KC	318

Raccords Vapeur 325

Jupe & Colliers 335

Colliers EN 14420-3	336
Jupe	346
Jubilee	356
Collier	361

Raccords Bride 367

Raccord & Accessoires 373

Raccords	374
Vannes & Clapets	386
Rondelles de protection	390
Pistolet de lavage	394
Joint	396
Cable anti-fouet	426

PT Accouplements 432

Tuyau de protection contre l'incendie 437

Tuyau en silicone 451

Sécurité au travail 474



Racorería general	13
Racor Tankwagon EN 14420 – 6	14
API Racores	28
Acople seco	34
Racor Camlok - EN 14420-7/Mil	38
Racor para la producción de nieve	98
Racor Guillemín	100
DSP Racores	121
Racor Storz	124
Racor para aire comprimido EA DIN3489 + Tipo USA	146
Racor - Express	158
Racor chorro de arena (Granallado)	162
Racor latón para agua 1/3 - 2/3	164
Racor Barcelona	179
Racor para contenedor IBC	181
Composite	197
Racor - Recubierto de PFA	207
Racores para alimentaria, química y farmacéutica	225
Racor CLAMP	226
Racor DIN 11851	242
Racor SMS 1145	276
Racor Macon	290
Terminal Rosca/Racor para manguera	299
TW - Terminal Rosca/ Racor de manguera de seguridad EN 14420-2	300
King Combination	318
Racor para manguera de vapor	325
Campanas para prensar y abrazaderas de seguridad	335
Abrazaderas de seguridad EN 14420-3	336
Campanas para prensar	346
Jubilee, abrazaderas y accesorios	356
Abrazaderas de seguridad	361
Bridas	367
Flexibles & Accesorios	373
NUEVO Flexibles	374
Válvulas de bola	386
Anillo de protección	390
Pistola de agua para limpieza industrial	394
Junta	396
Cables de seguridad para mangueras	426
PT Acoplamientos	432
Funda de protección contra incendios	437
NUEVO Mangueras de silicona	451
EPIS - Equipos de Protección Individual	474



Szybkozłącza	13
Złącza Tankwagen zgodnie EN 14420-6	14
Złącza API	28
Suchego sprzęgła	34
Złącza Camlock zgodnie EN 14420-7 / MIL	38
Złącza Camlock "Snow Master" do armatek śnieżnych	98
Złącza symetryczne - System Guillemin	100
Złącza DSP	121
Złącza strażackie	124
Złącza kłowe zgodnie DIN3489 + Typ Amerykański	146
Złącza kłowe do powietrza - Express	158
Złącza do piaskowania	162
Złącza kłowe do wody + 1/3 + 2/3 Króćce	164
Złącza - Barcelona	179
IBC-Armaturen	181
Composite	197
Złącza - Z powłoką PFA	207
Złączki dla przemysłu spożywczego	225
Złącza Clamp zgodnie	226
Złącza mleczarskie zgodnie DIN11851	242
Złącza SMS 1145	276
Złącza Macon	290
Złącza Macon	299
Złącza gwintowe do węży zgodnie EN 14420-2	300
Końcówki i łączniki - Typu CN	318
Końcówki i obejmy do pary wodnej	325
Tuleje zaciskowe i Obejmy skorupowe	335
Obejmy skorupowe zgodnie EN 14420-3	336
Tuleje zaciskowe	346
Jubilee - Opaski i Akcesoria	356
Opaski	361
Złącza kołnierzone	367
Złączki i Akcesoria	373
Złączki	374
Zawory kulowe/zwrotne	386
Ochrona przed uderzeniami	390
Pistolety do wody	394
Uszczelka	396
Linka zabezpieczająca Whipcheck do węży	426
PT Couplings	432
Wąż przeciwpożarowy	437
Wężę silikonowe	451
Bezpieczeństwo pracy	474



Racor Rápidos	13
Raccordi Tankwagon EN 14420 – 6	14
API Raccordi	28
Accoppiamento a secco	34
Raccordi Camlock EN 14420-7/Mil	38
Raccordi di produzione di neve	98
Raccordi Guillemin	100
DSP Raccordi	121
Raccordi Storz	124
Raccordi per aria compressa EA DIN3489 + Tipo USA	146
Raccordi - Express	158
Raccordo per sabbatura	162
Raccordi per acqua in ottone 1/3 - 2/3	164
Raccordi Barcelona	179
Raccordi IBC	181
Composite	197
Raccordi - Rivestimento in PFA	207
Raccordi per l'industria alimentare e chimica	225
Raccordi CLAMP DIN 32676	226
Raccordi DIN 11851	242
Raccordi SMS 1145	276
Raccordi Macon	290
Filetto terminale / raccordo per tubo flessibile	299
TW - Terminale filettatura / Raccordi per tubo flessibile di sicurezza EN 14420-2	300
King Combination	318
Raccordi per vapore	325
Boccole a pressare e morsetti di sicurezza	335
Morsetti di sicurezza EN 14420-3	336
Boccole a pressare	346
Jubilee, fascette di sicurezza ed accessori	356
Morsetti di sicurezza	361
Flange flessibili	367
Flessibile e accessori	373
Nuove flessibile	374
Valvole a sfera	386
Anello di protezione	390
Pistola per lavaggio	394
Guarnizione	396
Cavi di sicurezza per tubi	426
PT Accoppiamenti	432
Protezione antifiama per tubi	437
NUOVI tubi in silicone	451
DPI - Dispositivi Protezione Individuale	474



MCC GERMANY

Die MCC Millennium Coupling Germany GmbH ist spezialisiert auf die Herstellung und Distribution von Schlauch- und Armaturentechnik.

Unser Vertriebspartner ist der Technische Handel in Europa

UNSERE VORTEILE FÜR DEN TECHNISCHEN HANDEL

- Kein Mindestauftragswert
- Keine Verpackungseinheiten
- Niedrige Frachtkosten (Deutschland ab 300 Euro Armaturen frei Haus)
- Hohe Verfügbarkeit von über 5000 Artikeln auf 2000m² Lagerfläche
- Premium Service für Premium Partner: bei Bestellung bis 15 Uhr wird Ware am gleichen Tag versandt
- Alle gängigen europäischen Armaturen Systeme auf Lager
- Online Anfragen/Bestellungen möglich
- Sonderteilanfertigung möglich .

Die MCC Millennium Coupling Germany GmbH wurde 2011 mit einer klaren Vision gegründet: den technischen Handel in Europa mit eigenen, internationalen Fertigungsstätten zu verbinden. Heute zählen wir zu den Marktführern der europäischen Armaturenbranche und beliefern mehr als 28 Länder mit hochwertiger Schlauch- und Armaturentechnik.

Als Familienunternehmen legen wir besonderen Wert auf Qualität, gutem Service, einem schnellen Versandprozess, sowie Produktvielfalt.

Unser Produktsortiment umfasst eine breite Auswahl, von Industriearmaturen aus Edelstahl, Messing, Aluminium und Polypropylen bis hin zu Silikonschläuchen der USP Klasse VI für den Einsatz in Pharma- und Kosmetikanwendungen.

Zusätzlich bieten wir hochwertige PFA-ummantelte Armaturen, sowie eine umfassende Auswahl von Zertifikaten (u.a. 3.1 Zertifikate). Kurz gesagt: Wir haben immer die richtige Verbindung!

Unser Team ist für Sie erreichbar unter:

+49 (0) 22 41 93 25 80

info@mcc-germany.com

Langbaughstr. 5; DE-53842 Troisdorf

Öffnungszeiten:

Mo-Do:	8:00 Uhr - 12:00 Uhr 13:00 Uhr - 17:00 Uhr
Fr.:	8:00 Uhr - 12:00 Uhr 13:00 Uhr - 16:00 Uhr

MCC GERMANY

The MCC Millennium Coupling Germany GmbH is specialized in producing and distributing industrial hoses and coupling.



Our exclusive distribution partner is the European technical wholesale.

OUR ADVANTAGES FOR THE TECHNICAL WHOLESALERS

- No minimum order value
- No packaging units
- Low freight costs (free delivery in Germany from 300 Euro in couplings)
- High availability of over 5000 items in 2000m² warehouse
- Premium service for premium partners: goods are dispatched the same day if ordered by 3 p.m.
- All common European industrial hose coupling systems in stock
- Online inquiries/orders possible
- Customized production possible



MCC Millennium Coupling Germany GmbH was founded in 2011 with a clear vision: to connect technical wholesalers and dealers in Europe with its own international production facilities. Today, we are one of the market leaders in the European couplings industry and supply more than 28 countries with high-quality industrial hose and couplings solutions.

As a family business, we place particular emphasis on quality, good service, a fast-shipping process and product diversity.

Our product range includes a uniquely wide selection, from industrial fittings made of stainless steel, brass, aluminium and polypropylene to USP Class VI silicone hoses for use in pharmaceutical and cosmetic applications.

We also offer high-quality PFA-coated fittings and a comprehensive range of certificates (including 3.1 certificates). In other words: We always have the right connection!

You can reach our team at:

+49 (0) 22 41 93 25 80

info@mcc-germany.com

Langbaughstr. 5; DE-53842 Troisdorf

Opening times:

Mon-Thu:	8:00 a.m - 12:00 p.m 1:00 p.m - 05:00 p.m
Fri:	8:00 a.m - 12:00 p.m 1:00 p.m - 04:00 p.m



SCHNELL- KUPPLUNGEN

Tankwagenarmaturen EN 14420-6	14
API Tankwagenarmaturen	28
Trockenkupplungen	34
Hebelarmaturen-System, Kamlok - EN 14420-7/MIL	38
Schneekanonen-Kupplungen	98
Symmetrische Kupplungen - System Guillemin	100
DSP Kupplungen	121
Storz Kupplungen	124
Klauenkupplungen n. DIN3489 + US-Ausführung	146
Pressluftarmaturen-Express 25	158
Sandstrahlarmaturen	162
Wasserschlaucharmaturen 1/3+2/3 Verschraubungen/Sauger ..	164
Barcelona Armaturen	179

INFORMATIONEN

Tankwagenarmaturen

Die Tankwagenkupplung ist nach DIN EN 14420-6 genormt. Sie besteht aus einem Kupplungs-Mutterteil und einem Vaterteil. Das Mutterteil besteht aus einem drehbaren Spannring und einem inneren Kronenstück. In dem Kronenstück ist eine Formdichtung (oftmals aus Elastomeren) eingelegt.

Die TW-Armatur wird durch Aufdrehen des Spannringes auf die Nocken des Vaterteils gekuppelt. Der Hebel wird hierbei aufgestellt, um mehr Drehmoment aufzubringen. Der Hebel wird während des Betriebs wieder heruntergeklappt. Eine Rastung sichert gegen selbständiges Lösen des Spannringes.



Im gekuppelten Zustand greift das Kronenstück in die Nocken des Vaterteils und erzeugt so eine Verdrehsicherung. Dies hilft, dass sich die Verbindung, beim Bewegen eines Schlauches, nicht löst.

WARUM MCC?

- Präzise Nockenführung ermöglicht eine optimale und dauerhafte Dichtung und vermeidet Kippen
- Geschmiedete Hebel und feinkörnige Werkstoffe sorgen für eine hohe Festigkeit und Langlebigkeit
- Rippen sind auf den Schlauchstutzen auf die Optimale Eindichtung der Schläuche abgestimmt
- Vielfältige Ausführungen (u.a. abgewinkelten Hebel für enge Räume um die Handhabung zu erleichtern)
- PFA Beschichte Armaturen erhältlich (werden häufig verwendet, wenn Flexibilität und ein höherer Dauerbetriebstemperaturbereich erforderlich ist.)



TECHNISCHE INFORMATIONEN

- Normen: DIN EN 14420-6
- Gewinde: ISO 228 flachdichtend (Abmessungen Gewindelänge bzw. Gewindetiefe vergleichbar DIN EN 14420-5)
- Betriebsdruck: -0,8 bis 16 bar bei 65°C
- Werkstoffe:
Armaturen: Armaturenwerkstoffe: Messing, Edelstahl, Aluminium, Polypropylen
Kupplungsdichtung: NBR, FKM, CSM
Gewindedichtungen: PTFE, PU, FKM, EPDM, NBR, Silikon, nach EU1935/2004, FDA für Lebensmittel

EINSATZGEBIET

Die Tankwagenkupplung wird gerne an Be- und Entladestellen eingesetzt. Dies liegt an der leichten Bedienbarkeit. Ursprünglich fand diese Kupplung in der Messing Ausführung in der Mineralöl-industrie ihren Einsatz. Von dort aus hielt sie Einzug in die Chemieindustrie. Sie ist eher im deutschsprachigem Raum und Niederlande verbreitet.

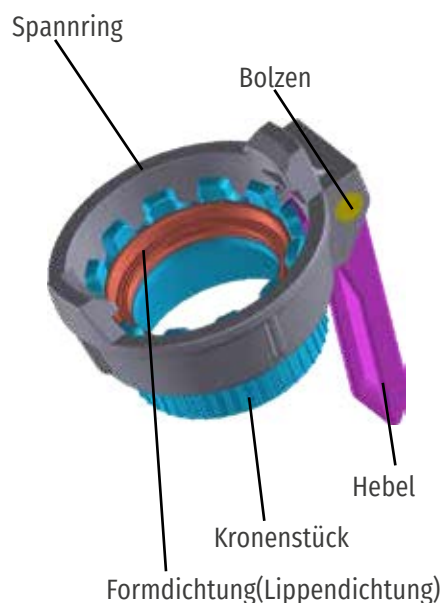



The TW coupling is standardized according to DIN EN 14420-6. It consists of a male and female part. The female part consists of a rotatable clamping ring and an inner crown piece. A molded gasket, mostly made of elastomers, is inserted in the crown piece.

The TW is coupled by screwing the

clamping ring onto the cams of the male part. The lever is raised to apply more torque. The lever is folded down again during operation to prevent the clamping ring from loosening on its own.

When coupled, the crown piece engages in the cams of the male part and thus creates an anti-rotation lock. This helps to ensure that the connection does not come loose when a hose is moved.

WHY MCC?

- Precise cam guidance enables an optimum and durable gasket and prevents tilting
- Forged levers and fine-grained materials ensure high strength and durability
- Ribs are matched to the hose nozzle for optimum sealing of the hoses
- Wide range of designs (including angled levers for tight spaces to facilitate handling)
- PFA coated fittings available (often used when flexibility and a higher continuous operating temperature range is required)



TECHNICAL INFORMATION

- Norm: DIN EN 14420-6
- Thread: ISO 228 flat sealing (dimensions of thread length and thread depth comparable to DIN EN 14420-5)
- Working pressure: -0.8 to 16 bar at 65°C
- Material:
 - Fittings: brass, stainless steel, aluminum, polypropylene,
 - Coupling seal: NBR, FKM, CSM
 - Thread gaskets: PTFE, PU, FKM, EPDM, NBR, silicone, according to EU1935/2004, FDA for foodstuffs

AREA OF APPLICATION

The TW coupling is often used at loading and unloading points. This is due to its ease of use. The brass version of this coupling was originally used in the mineral oil industry. From there, it found its way into the chemical industry. It is more popular in German-speaking countries and the Netherlands.

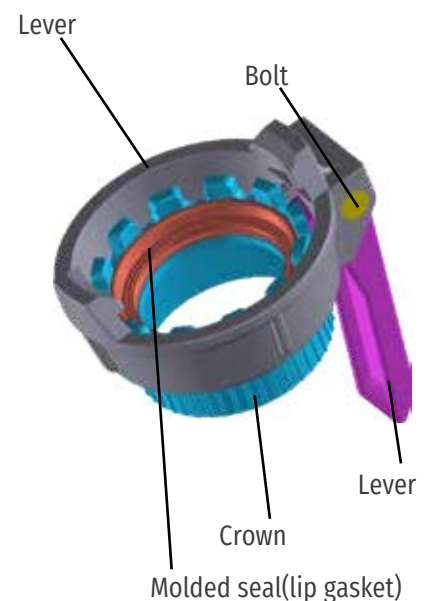



TW-Kupplung Typ MK mit BSPP - Innengewinde (Komplett)

mit CSM Lippendichtung und PTFE Gewindedichtung

Female coupler type MK BSPP female thread (complete) - CSM lip gasket PTFE thread-tasket
 Raccord type MK taraudé femelle BSPP (Complet) - Joint CSM pour raccord - Joint de fi letage PTFE
 TW-Acople hembra tipo MK con rosca hembra BSPP (completo) - Junta labial CSM Junta de rosca de PTFE
 TW Gniazdo typ MK z gwintem wewnętrznym BSPP (kompletny) - Uszczelka profilowa CSM Uszczelka o-ring PTFE
 TW-Tipo MK con filettato femmina BSPP (completo) - CSM, guarnizione filetatto PTFE

Part-No.	Material	WP	Dimension	Thread	Price
2MKS	SS 1.4408	16 bar	DN50	G2"	
3MKS	SS 1.4408	16 bar	DN80	G3"	
4MKS **	SS 1.4408	16 bar	DN100	G4"	

**einteilig - mit O-Ring statt Lippendichtung
 one pice - with O-ring instead of lip gasket

TW - Kupplung Typ MK mit BSPP - Innengewinde (Komplett) PFA ausgekleidet

mit FKM Lippendichtung

Female coupler type MK BSPP female thread (complete) PFA coated - FKM lip gasket
 Raccord type MK taraudé femelle BSPP (Complet) Revêtu de PFA - Joint pour raccord FKM
 TW- Acople hembra tipo MK con rosca hembra BSPP (completo) Recubierto de PFA - Junta FKM
 TW Gniazdo typ MK z gwintem wewnętrznym BSPP (kompletny) Z powłoką PFA - Uszczelka profilowa FKM
 TW - Tipo MK con filettato femmina BSPP (completo) Rivestimento in PFA - guarnizione FKM

NEW



Part-No.	Material	WP	Shank	Thread	Price
2MKSPFA-W	SS 1.4408 PFA white coated	25 bar	DN50	G2"	
3MKSPFA-W	SS 1.4408 PFA white coated	25 bar	DN80	G3"	
4MKSPFA-W**	SS 1.4408 PFA white coated	25 bar	DN100	G4"	
2MKSPFA-B	SS 1.4408 PFA black coated	25 bar	DN50	G2"	
3MKSPFA-B	SS 1.4408 PFA black coated	25 bar	DN80	G3"	
4MKSPFA-B**	SS 1.4408 PFA black coated	25 bar	DN100	G4"	

**einteilig - mit O-Ring statt Lippendichtung
 one pice - with O-ring instead of lip gasket



CONDUCTIVE



TW - Kupplung Typ MK (Spannringhebel)

Female coupler type MK (lever)

Raccord type MK (levier)

TW- Acople hembra tipo MK (palanca)

TW Gniazdo typ MK (Dźwignia pierścienia mocującego)

TW - Tipo MK senza corona (leva)



Part-No.	Material	WP	Dimension	Thread	Price
2MKSS	SS 1.4408	16 bar	DN50	G2"	
3MKSS	SS 1.4408	16 bar	DN80	G3"	

TW-Kupplung Typ MK (nur Spannringhebel mit 45° Hebel)

Female coupler type MK (only lever with 45° lever)

Raccord type MK (uniquement levier 45°)

TW-Acople hembra tipo MK (sin corona con palanca de 45°)

TW Gniazdo typ MK (Dźwignia pierścienia mocującego z 45 klamką)

TW-Tipo MK senza corona (leva singola leva a 45°)



NEW

Part-No.	Material	WP	Dimension	Thread	Price
2MKSS45	SS 1.4408	16 bar	DN50	G2"	

TW-Kupplung Typ MK mit BSPP – Innengewinde (Komplett mit 90° Hebel)

mit CSM Lippendichtung und PTFE Gewindedichtung

Female coupler type MK BSPP female thread (with 90° lever) - CSM lip gasket PTFE thread-gasket

Raccord type MK taraudé femelle BSPP (levier 90°) - Joint CSM pour raccord - Joint de filetage PTFE

TW-Acople hembra tipo MK con rosca hembra BSPP (con palanca de 90°) - Junta labial CSM Junta de rosca de PTFE

TW Gniazdo typ MK z gwintem wewnętrznym BSPP (z 90° klamką) - Uszczelka profilowa CSM Uszczelka o-ring PTFE

TW-Tipo MK filettato femmina BSPP (leva a 90°) - CSM Guarnizione filettato PTFE



Part-No.	Material	WP	Dimension	Thread	Price
3MKS90	SS 1.4408	16 bar	DN80	G3"	





TW-Kupplung Typ MK mit BSPP – Innengewinde (nur Kronenring)

mit CSM Lippendichtung und PTFE Gewindedichtung

Female coupler type MK BSPP female thread (only crown) – CSM lip gasket PTFE thread-gasket
 Raccord type MK taraudé femelle BSPP (uniquement la couronne) – Joint CSM pour raccord - Joint de filetage PTFE
 TW-Acople hembra tipo MK con rosca hembra BSPP (solo corona) - Junta labial CSM Junta de rosca de PTFE
 TW Gniazdo typ MK z gwintem wewnętrznym BSPP (Korona) – Uszczelka profilowa CSM Uszczelka o-ring PTFE
 TW-Tipo MK con filettato femmina BSPP (corona) – CSM guarnizione filettato PTFE

Part-No.	Material	WP	Dimension	Thread	Price
2MKS	SS 1.4408	16 bar	DN50	G2"	
3MKS	SS 1.4408	16 bar	DN80	G3"	



TW - Kupplung Typ VK mit BSPP - Innengewinde

mit PTFE Gewindedichtung

Male adapter type VK BSPP female thread - PTFE thread-gasket
 Raccord type VK taraudé femelle BSPP - Joint de filetage PTFE
 TW- Racor macho tipo VK con rosca hembra BSPP- Junta de rosca PTFE
 TW Wtyk typ VK z gwintem wewnętrznym BSPP- Uszczelka o-ring PTFE
 Raccordo maschio tipo VK filettato femmina BSPP - Guarnizione filettato PTFE

Part-No.	Material	WP	Dimension	Thread	Price
2VKS	SS 1.4408	16 bar	DN50	G2"	
3VKS	SS 1.4408	16 bar	DN80	G3"	
4VKS	SS 1.4408	16 bar	DN100	G4"	



TW - Kupplung Typ VK mit BSPP Innengewinde PFA ausgekleidet

Male adapter type VK BSPP female thread - PFA coated

Raccord type VK taraudé femelle BSPP - Revêtu de PFA

TW- Racor macho tipo VK con rosca hembra BSPP- Recubierto de PFA

TW Wtyk typ VK z gwintem wewnętrznym BSPP - Z powłoką PFA

Raccordo maschio tipo VK filettato femmina BSPP - Rivestimento in PFA

NEW

Part-No.	Material	WP	Shank	Thread	Price
2VKSPFA-W	SS 1.4408	25 bar	DN50	G2"	
3VKSPFA-W	SS 1.4408	25 bar	DN80	G3"	
4VKSPFA-W	SS 1.4408	25 bar	DN100	G4"	
2VKSPFA-B	SS 1.4408 PFA black coated	25 bar	DN50	G2"	
3VKSPFA-B	SS 1.4408 PFA black coated	25 bar	DN80	G3"	
4VKSPFA-B	SS 1.4408 PFA black coated	25 bar	DN100	G4"	



CONDUCTIVE

TW - Kappe Typ MB ohne Kette

CSM Dichtung

Cap MB for VK without chain - CSM gasket

Bouchon MB pour raccord VK - Joint CSM

TW- Tapa hembra tipo MB para VK sin cadena - Junta CSM

TW Pokrywa typ MB do VK bez łańcuszka - Uszczelka CSM

TW - Tappo MB per VK senza catena - Guarnizione CSM



Part-No.	Material	WP	Dimension	Price
2MBS	SS 1.4408	16 bar	DN50	
3MBS	SS 1.4408	16 bar	DN80	
4MBS	SS 1.4408	16 bar	DN100	





TW - Stopfen Typ VB ohne Kette

Plug VB for MK without chain
 Bouchon VB pour raccord MK - sans chaîne
 TW- Tapón macho tipo VB para MK sin cadena
 TW Korek typ VB do MK bez łańcuszka - bez łańcuszka
 TW - Tappo VB per MB - senza catena -

Part-No.	Material	WP	Dimension	Price
2VBS	SS 1.4408	16 bar	DN50	
3VBS	SS 1.4408	16 bar	DN80	
4VBS	SS 1.4408	16 bar	DN100	



TW - MK Kupplung einteilig mit Rillenstutzen für Klemmschaleneinband - ohne Spannringhebel mit CSM Lippendichtung

TW MK coupling one piece with serrated shank for safety clamps - without lever with CSM lip gasket
 Douille cannelée monobloc pour montage collier 1/2 coquille - sans Levier - Joint pour raccord CSM
 TW - Acople MK pieza única con espiga dentada para abrazadera de seguridad - sin palanca y junta CSM
 TW Złącze typ MK jednoczęściowe z karbowaną końcówką do węża pod obejmę skorupową - bez pierścieni uszczelniającej z uszczelką profilową
 TW - Tipo MK portagomma femmina - senza leva con guarnizione CSM

Part-No.	Material	WP	Dimension	Shank	Price
MK50ST	SS 1.4408	16 bar	DN50	50mm	
MK80ST	SS 1.4408	16 bar	DN80	76mm	



TW - VK Kupplung einteilig mit Rillenstutzen für Klemmschaleneinband

TW VK coupling one piece with serrated shank for safety clamps
 Douille cannelée monobloc pour montage collier coquille
 TW - Acople VK pieza única con espiga dentada para abrazadera de seguridad
 TW Złącze typ VK jednoczęściowe z karbowaną końcówką do węża pod obejmę skorupową
 TW -Tipo VK portagomma maschio

Part-No.	Material	WP	Dimension	Shank	Price
VK50ST	SS 1.4408	16 bar	DN50	50mm	
VK80ST	SS 1.4408	16 bar	DN80	76mm	



TW-Kupplung Typ MK mit BSPP - Innengewinde (Komplett)

mit NBR Lippendichtung und PU Gewindedichtung

Female coupler type MK BSPP female thread (complete) - NBR lip gasket PU thread gasket

Raccord type MK taraudé femeller BSPP (Complet) - Joint pour raccord NBR - Joint de filetage PU

TW- Acople hembra tipo MK con rosca hembra BSPP (completo) - Junta labial NBR Junta de rosca de PU

TW Gniazdo typ MK z gwintem wewnętrznym BSPP (kompletny) - Uszczelka profilowa NBR Uszczelka o-ring PU

TW - Tipo MK con filettato femmina BSPP (completo) - NBR, guarnizione filettato PU



Part-No.	Material	WP	Dimension	Thread	Price
2MKB	BR / CW617N	16 bar	DN50	G2"	
3MKB	BR / CW617N	16 bar	DN80	G3"	
4MKB**	BR / CW617N	16 bar	DN100	G4"	

**einteilig - mit O-Ring statt Lippendichtung

one piece - with O-Ring instead of Lip gasket

TW - Kupplung Typ MK (Spannringhebel)

Female coupler type MK (lever)

Raccord type MK (levier)

TW- Acople hembra tipo MK (palanca)

TW Gniazdo typ MK (Dźwignia pierścienia mocującego)

TW - Tipo MK senza corona (leva)



Part-No.	Material	WP	Dimension	Thread	Price
2MKBS	BR / CW617N	16 bar	DN50	G2"	
3MKBS	BR / CW617N	16 bar	DN80	G3"	

TW-Kupplung Typ MK mit BSPP – Innengewinde (nur Kronenring)

mit NBR Lippendichtung und PU Gewindedichtung

Female coupler type MK BSPP female thread (only crown) - NBR lip gasket PU thread-gasket

Raccord type MK taraudé femeller BSPP (uniquement la couronne) - Joint NBR pour raccord - Joint de filetage PU

TW- Acople hembra tipo MK con rosca hembra BSPP (solo la corona) - Junta labial NBR Junta de rosca de PU

TW Gniazdo typ MK z gwintem wewnętrznym BSPP (Korona) - Uszczelka profilowa NBR Uszczelka PU

TW - Tipo MK con filettato femmina BSPP (corona) - NBR guarnizione filettato PU



Part-No.	Material	WP	Dimension	Thread	Price
2MKBK	BR / CW617N	16 bar	DN50	G2"	
3MKBK	BR / CW617N	16 bar	DN80	G3"	





TW - Kupplung Typ VK mit BSPP - Innengewinde
mit PU Gewindedichtung

Male adapter type VK BSPP female thread - PU thread-gasket
 Raccord type VK taraudé femeller BSPP - Joint de filetage PU
 TW- Racor macho tipo VK con rosca hembra BSPP - Junta de rosca PU
 TW Wtyk typ VK z gwintem wewnętrznym BSPP- Uszczelka o-ring PU
 TW - Tipo VK con filettato femmina BSPP senza leva - Guarnizione filettato PU

Part-No.	Material	WP	Dimension	Thread	Price
2VKB	BR / CW617N	16 bar	DN50	G2"	
3VKB	BR / CW617N	16 bar	DN80	G3"	
4VKB	BR / CW617N	16 bar	DN100	G4"	



TW - Kappe Typ MB ohne Kette
NBR Dichtung

Cap MB for VK without chain - NBR gasket
 Bouchon MB pour raccord VK - Joint NBR
 TW- Tapa hembra tipo MB para VK sin cadena - Junta NBR
 TW Pokrywa typ MB do VK bez łańcuszka - Uszczelka NBR
 TW - Tappo MB per VK senza catena - Guarnizione NBR

Part-No.	Material	WP	Dimension	Price
2MBB	BR / CW617N	16 bar	DN50	
3MBB	BR / CW617N	16 bar	DN80	
4MBB	BR / CW617N	16 bar	DN100	



TW - Stopfen Typ VB ohne Kette

Plug VB for MK without chain
 Bouchon VB pour raccord MK - sans chaîne
 TW Tapón VB para MK - sin cadena
 TW Korek typ VB do MK bez łańcuszka - bez łańcuszka
 TW Tappo VB per MK senza catena

Part-No.	Material	WP	Dimension	Price
2VBB	BR / CW617N	16 bar	DN50	
3VBB	BR / CW617N	16 bar	DN80	
4VBB	BR / CW617N	16 bar	DN100	



TW - MK Kupplung einteilig, mit Rillenstutzen für Klemmschaleneinband

ohne Spannringhebel mit NBR Lippendichtung

TW MK coupling one piece with serrated shank for safety clamps - without lever with NBR lip gasket

Douille cannelée monobloc pour montage collier coquille - sans levier avec joint NBR pour raccord

TW- Acople MK pieza única con espiga dentada para abrazaderas de seguridad - sin palanca con junta NBR

TW Złącze typ MK jednoczęściowe z karbowaną końcówką do węża pod obejmę skorupową - bez pierścienia uszczelniającej z uszczelką profilową NBR

TW - Tipo MK portagomma femmina - senza leva con guarnizione NBR



Part-No.	Material	WP	Dimension	Shank	Price
MK50BT	BR / CW617N	16 bar	DN50	50mm	
MK80BT	BR / CW617N	16 bar	DN80	76mm	

TW - VK Kupplung einteilig, mit Rillenstutzen für Klemmschaleneinband

TW VK coupling one piece with serrated shank for safety clamps

Douille cannelée monobloc pour montage collier coquille

TW Acople VK pieza única con espiga dentada para abrazaderas de seguridad

TW Złącze typ VK jednoczęściowe z karbowaną końcówką do węża pod obejmę skorupową

TW Tipo VK portagomma maschio



Part-No.	Material	WP	Dimension	Shank	Price
VK50BT	BR / CW617N	16 bar	DN50	50mm	
VK80BT	BR / CW617N	16 bar	DN80	76mm	

TW - Kronenring mit Außengewinde

mit NBR Lippendichtung

TW crownring with male thread - NBR lip gasket

Raccord type MK couronne filetée mâle - Joint pour raccord NBR

TW Corona con rosca macho - Junta NBR

TW Korona z gwintem zewnętrznym - Uszczelka profilowa NBR

TW Corona con filettato maschio - Guarnizione NBR



Part-No.	Material	WP	Dimension	Thread	Price
2MKBK-1.5AG	BR / CW617N	16 bar	DN50	1 1/2"	
2MKBK-2AG	BR / CW617N	16 bar	DN50	2"	





TW - Kappe Typ MB ohne Kette

NBR Dichtung

Cap MB for VK without chain - NBR gasket

Bouchon MB pour raccord VK - Joint NBR

TW- Tapa hembra tipo MB para VK sin cadena - Junta NBR

TW Pokrywa typ MB do VK bez łańcuszka - Uszczelka NBR

TW - Tappo MB per VK senza catena - Guarnizione NBR

Part-No.	Material	WP	Dimension	Price
2MBA	Aluminum	16 bar	DN50	
3MBA	Aluminum	16 bar	DN80	
4MBA	Aluminum	16 bar	DN100	



TW - Stopfen Typ VB ohne Kette

Plug VB for MK without chain

Bouchon VB pour raccord MK - sans chaîne

TW- Tapón VB para MK - sin cadena

TW Korek typ VB do MK bez łańcuszka - bez łańcuszka

TW - Tappo VB per MK senza catena

Part-No.	Material	WP	Dimension	Price
2VBA	Aluminum	16 bar	DN50	
3VBA	Aluminum	16 bar	DN80	
4VBA	Aluminum	16 bar	DN100	



TW-Schlüssel

TW spanner
Clé pour Tankwagen
Llave plana TW
TW Klucz montażowy
TW chiave piatta



Part-No.	Material	Dimension	Dimension	Price
SGE	SS 304	DN50	DN100	

Zubehör - Kette

Accessories - chain
Accessoires - chaîne
Accesorios - cadena
Akcesoria - łańcuszek
Accessori - Catenella



Part-No.	Material	Price
36310 ⁽¹⁾	Brass	
36310-SS ⁽²⁾	Stainless Steel	
SS12CH ⁽³⁾	Stainless Steel	

Schauglas mit beidseitigem BSPP Außengewinde, Material PC

Sight glass with both sides BSPP male thread, polycarbonate
Tube transparent Filetage mâle BSPP des deux côtés, polycarbonate
Mirilla con rosca macho BSPP en ambos lados, material PC
Tubo transparente rosca macho BSPP en ambos lados, policarbonato
Tubo trasparente con filetto maschio BSPP su entrambi i lati, policarbonato



Part-No.	Material	WP	Thread	Thread	Length	Price
SGBSPM200	Polycarbonate	10 bar	2"	2"	200mm	
SGBSPM300	Polycarbonate	10 bar	3"	3"	200mm	
SGBSPM400	Polycarbonate	10 bar	4"	4"	200mm	



Zapfpistole Polypropylen

Nozzle polypropylene

Pistolet de distribution PP

Boquerel de PP

Dysza PP

Pistola di riempimento in PP

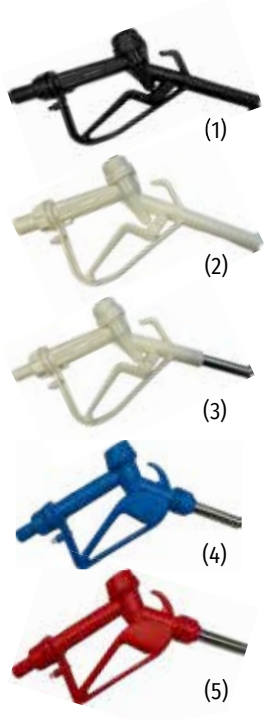

Part-No.	Material	WP	Inlet	Outlet	Price
NZP100HTP075	(1) Black - PP outlet Medium: diesel, kerosene, no corrosive liquid	5 bar	3/4"	1"	
NZP100HTP100	(1) Black - PP outlet Medium: diesel, kerosene, no corrosive liquid	5 bar	1"	1"	
NZP100HTP075-W	(2) White - PP outlet Medium: diesel, gasoline, kerosene, AdBlue and other low corrosive liquids	5 bar	3/4"	1"	
NZP100HTP100-W	(2) White - PP outlet Medium: diesel, gasoline, kerosene, AdBlue and other low corrosive liquids	5 bar	1"	1"	
NZS075HTP075-W	(3) White - SS304 outlet Medium: diesel, gasoline, kerosene, AdBlue and other low corrosive liquids	5 bar	3/4"	3/4"	
NZS075HTP100-W	(3) White - SS304 outlet Medium: diesel, gasoline, kerosene, AdBlue and other low corrosive liquids	5 bar	1"	3/4"	
NZS075HTP075-B	(4) Blue - FSS304 outlet Medium: diesel, gasoline, kerosene, AdBlue and other low corrosive liquids	5 bar	3/4"	3/4"	
NZS075HTP075-R	(5) Red - SS304 outlet Medium: diesel, gasoline, kerosene, AdBlue and other low corrosive liquids	5 bar	3/4"	3/4"	

10 bar Platzdruck

10 bar burst pressure



Zapfpistole mit Schlauch

Nozzle PP with hose

Pistolet de distribution PP avec tuyau

Boquerel de PP con manguera

Dysza PP z wężem

Pistola di riempimento in PP con tubo flessibile



Part-No.	Hose	WP	Side 1	Side 2	Price
NZS075IBCF60-2M	PVC black, 2 meter length	5 bar	white PP Nozzle Outlet 3/4" in SS304	IBC S60X6 female thread, black	

10 bar Platzdruck

10 bar burst pressure



INFORMATIONEN

API-Tankwagenarmaturen



Die API-Kupplung, ursprünglich für die Kraftstoffbetankung entwickelt, ist eine zuverlässige Trockenkupplung für den Einsatz mit Ölen und Kohlenwasserstoffen.

Sie erfüllt international anerkannte Standards und verfügt über die kanadische CRN-Zulassung. Ein wesentliches Merkmal dieser Kupplung ist die präzise

Nockenführung im Inneren, die eine optimale Funktionalität gewährleistet.

Die Produkte von MCC sind mit anlagen- oder TKW-seitigen Varterteilen kompatibel. API-Kupplungen werden in der Regel aus Aluminiumlegierungen gefertigt, da diese durch ihr geringes Gewicht einfach zu handhaben sind. Es ist jedoch zu beachten, dass Aluminiumkupplungen

bei einem Fall Schlagfunken erzeugen können und somit nicht für den Einsatz in ATEX-Bereichen geeignet sind.

Trotz der potenziellen Einschränkungen erfreuen sich Aluminium-API-Kupplungen aufgrund ihres niedrigen Gewichts großer Beliebtheit und haben sich in zahlreichen Anwendungen bewährt.

WARUM MCC?

- Armatur ist aus duktilem zähem Aluminium gefertigt
- Hochwertige Hebel in Stahl, sowie zusätzliche Hebelverriegelung auch einzeln erhältlich
- Vielfältige Anschlußstücke wie ISO 228 Anschlußgewinde, Winkelstücke, Sichtfenster
- Winkelstücke verfügbar, die ein Abknicken des Schlauches verhindern
- Kompatible Adapter erhältlich



TECHNISCHE INFORMATIONEN

- a. Normen: CRN Kanada
- b. Werkstoffe:
 Armaturen: Aluminium AIMGS1
 Hebel: Messing
 Schaugläser: Silikatglass

EINSATZGEBIET

- Mineralölverladung
 Vollschlauchsysteme
 Verladung von Kohlenwasserstoffen wie Benzin oder Additiven

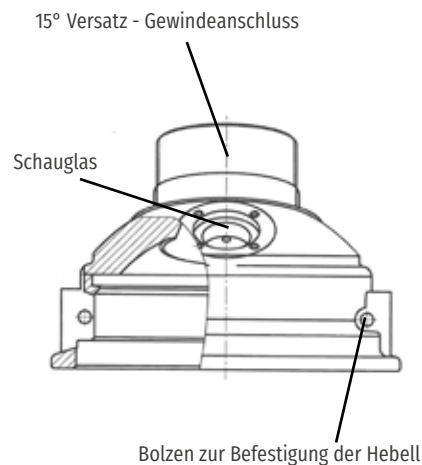
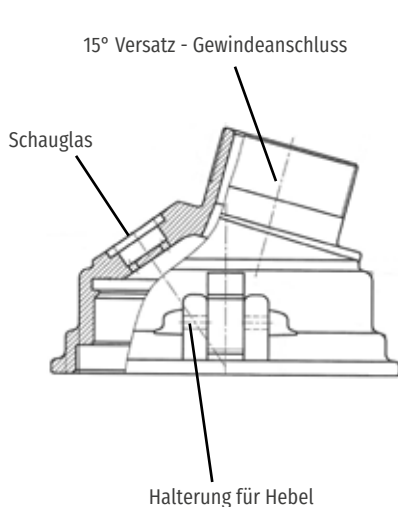



INFORMATION API-Couplings

The API coupling, originally developed for fuel refueling, is a reliable dry coupling for use with oils and hydrocarbons.

It meets internationally recognized standards and has Canadian CRN approval. A key feature of this coupling is the precise cam guide inside, which ensures optimum functionality.

MCC products are compatible with plant or TKW-side male parts. API couplings are usually made of aluminum alloys, as they are easy to handle due to their low weight. However, it should be noted that aluminum couplings can generate impact sparks if dropped and are therefore not suitable for use in ATEX areas.

Despite the potential limitations,

aluminum API couplings are very popular due to their low weight and have proven themselves in numerous applications.

WHY MCC?

- Fitting is made of ductile, tough aluminum
- High-quality lever in steel and additional lever lock also available separately
- Wide range of connectors such as ISO 228 connection threads, elbows, inspection windows
- Elbows available to prevent the hose from kinking
- Compatible adapters available



TECHNICAL INFORMATION

- Norm: CRN Canada
- Material:
Coupling: Aluminium AIMGS1
Lever: Brass
View: silicate glass

AREA OF APPLICATION

- Mineral oil loading
- Full hose systems
- Loading of hydrocarbons such as gasoline or additives

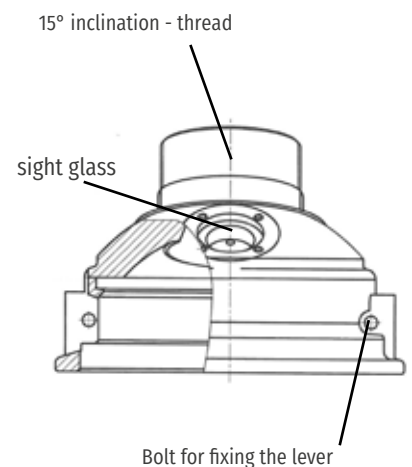
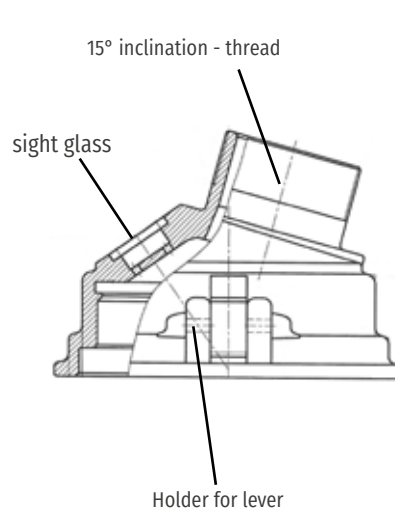



API Mutterteil-Kupplung mit Schlauchstutzen

mit NBR Dichtung

API female coupling with hose shank - NBR gasket

Coupleur pour récupération de vapeur à douille annelée et hélicoïdale - Joint NBR

API para manguera de vapor - Junta NBR

Złącze żeńskie API z dyszą do węża - Uszczelka NBR

Accoppiatore tipo API elicoidale per tubo di vapore - Guarnizione NBR

Part-No.	Material	WP	Dimension	Shank	Price
API300H76	Aluminum	10 bar	DN80	76mm	
API400H76	Aluminum	10 bar	DN100	76mm	
API400H100	Aluminum	10 bar	DN100	100mm	



API Mutterteil-Kupplung mit BSPP Innengewinde

mit NBR Dichtung

API female coupling with BSPP female thread - NBR gasket

Coupleur API taraudé femelle BSPP - Joint NBR

API rosca hembra BSPP- Junta NBR

Złącze żeńskie API z gwintem wewnętrznym BSPP- Uszczelka NBR

Accoppiatore tipo API filettatura femina - Guarnizione NBR

Part-No.	Material	WP	Dimension	Thread	Price
API300F300	Aluminum	10 bar	DN80	3"	
API400F300	Aluminum	10 bar	DN100	3"	
API400F400	Aluminum	10 bar	DN100	4"	



API Mutterteil-Kupplung mit BSP AG und 15° Versatz

mit NBR Dichtung

Female API gravity drop adapter with BSP male thread and 15° inclination - NBR gasket

Coupleur API filetage extérieur et inclinaison de 15° - Joint NBR

API rosca exterior e inclinación de 15° - Junta NBR

Złącze żeńskie API z gwintem zewnętrznym BSP, kąt 15° - Uszczelka NBR

Accoppiatore tipo API filettatura esterno e inclinazione di 15° - Guarnizione NBR

Part-No.	Material	WP	Dimension	Thread	Price
API400M300-15	Aluminum	10 bar	DN100	3"	
API400M400-15	Aluminum	10 bar	DN100	4"	



API Mutterteil-Kupplung mit BSP AG, 15° Versatz und Sichtfenster mit NBR Dichtung

Female API gravity drop adapter with BSP male thread, 15° inclination and sight glass - NBR gasket

Coupleur API filetage extérieur et inclinaison de 15° et fenêtre d'affichage - Joint NBR

API rosca exterior e inclinación de 15° y ventana de visualización - Junta NBR

Złącze żeńskie API z gwintem zewnętrznym BSP i z okienkiem, kąt 15° - Uszczelka NBR

Accoppiatore tipo API filettatura esterno e inclinazione di 15° e finestra di visualizzazione - Guarnizione NBR



Part-No.	Material	WP	Dimension	Thread	Price
API400M300-15SG	Aluminum	10 bar	DN100	3"	
API400M400-15SG	Aluminum	10 bar	DN100	4"	

API Mutterteil-Kupplung auf Kamlok Vaterteil und 15° Versatz mit NBR Dichtung

Female API gravity drop adapter with C&G male adapter and 15° inclination - NBR gasket

Coupleur API - sur la partie mâle et inclinaison de 15° - Joint NBR

API en la parte macho e inclinación de 15° - Junta NBR

Złącze żeńskie API z Camlock wtykiem, kąt 15° - Uszczelka NBR

Accoppiatore tipo API nella parte maschile e inclinazione di 15° - Guarnizione NBR



Part-No.	Material	WP	Dimension	Male	Price
API400A300-15	Aluminum	10 bar	DN100	3"	
API400A400-15	Aluminum	10 bar	DN100	4"	

API Mutterteil-Kupplung auf Kamlok Vaterteil, 15° Versatz und Sichtfenster mit NBR Dichtung

Female API gravity drop adapter with C&G male adapter and 15° inclination and sight glass - NBR gasket

Coupleur API - sur la partie mâle et inclinaison de 15° et fenêtre d'affichage - Joint NBR

API en la parte macho e inclinación de 15° y ventana de visualización - Junta NBR

Złącze żeńskie API z Camlock wtykami i z okienkiem, kąt 15° - Uszczelka NBR

Accoppiatore tipo API nella parte maschile e inclinazione di 15° e finestra di visualizzazione - Guarnizione NBR



Part-No.	Material	WP	Dimension	Male	Price
API400A300-15SG	Aluminum	10 bar	DN100	3"	
API400A400-15SG	Aluminum	10 bar	DN100	4"	



API Mutterteil-Kupplung auf Kamlok Mutterteil-Kupplung und 15° Versatz mit NBR Dichtung



Female API gravity drop adapter with C&G female coupling and 15° inclination - NBR gasket

Coupleur API - sur écrou et inclinaison de 15° - Joint NBR

API en tuerca e inclinación de 15° - Junta NBR

Złącze żeńskie API z Camlock gniazdem, kąt 15° - Uszczelka NBR

Accoppiatore tipo API filettatura e inclinazione di 15° - Guarnizione NBR

Part-No.	Material	WP	Dimension	Female	Price
API400B300-15	Aluminum	10 bar	DN100	3"	
API400B400-15	Aluminum	10 bar	DN100	4"	

API Ersatzhebel

Replacement handle for API coupling

Kit de réparation - levier

Set de reparación para acoples API

Uchwyt zamienny do złącza API

Set di riparazioni per accoppiamenti di API



Part-No.	Material	Description	Price
APIH1BR	Brass	Steel Ring Steel Pin For Couplings: API300H76, API400H76, API400H100, API300F300, API400F300, API400F400, API400M300-15, API400M400-15, API400A300-15, API400A400-15, API400B300-15, API400B400-15	
APIH2BR	Brass	Handle without hole Steel Pin For Couplings: API400M300-15SG, API400M400-15SG, API400A300-15SG, API400A400-15SG	
APIH3BR	Brass	Steel Ring Steel Pin For Couplings: API400G300-15SG	



INFORMATIONEN

Trockenkupplung



Trockenkupplung oder auch Dry Disconnect Couplings, dichten während des Entkuppelns die Schlauch- und Rohrseite ab, so dass kein Medium auslaufen kann. Solche Sicherheitskupplungen sind in Anwendungen erforderlich, bei denen kein Medium in die Umwelt gelangen darf und Schnellkupplungen untersagt sind.

Diese Sicherheitskupplungen gibt es in den unterschiedlichsten Ausführungen. Daher sollten Kupplungsteil und Mutterteil möglichst von einem Hersteller genommen werden. Diese Kupplung stellt ein bewährtes System dar. Sie ist für den US-militärischen Einsatz entwickelt worden und findet sich im heutigen STARNAK Standard wieder. Diese Kupplung

öffnet durch eine 120° Drehbewegung, nachdem die Rollen im Mutterteil hinter den Steg des Kupplungsteils gegriffen haben. Die Drehbewegung schiebt die beiden Ventile in das Kupplungsteil. Das Entkuppeln erfolgt durch Zurückdrehen. Erst wenn die Ventile dichten, lässt sich das Mutterteil trennen.

WARUM MCC?

- Armatur ist grundsätzlich mit hochwertigen FKM-Dichtungen ausgestattet.
- Die Gehäusewerkstoffe sind aus SS 316 Edelstahl
- Die Hebel sind aus bruchfesten Werkstoffen, ergonomisch geformt
- Die Ventile haben eine zusätzliche stirnseitige Dichtung, die die Tropfenengen reduziert



TECHNISCHE INFORMATIONEN

- a. Starnak Standard
- b. Anschlussgewinde: ISO 228 flachdichtend (Abmessungen Gewindelänge bzw. Gewindetiefe vergleichbar DIN EN 14420-5)
- c. Flansch entsprechend EN 1092
- d. Betriebsdruck: -0,8 bis 25 bar bei 65°C
- e. Werkstoffe:
Armaturen: Edelstahl
Kupplungsdichtung: FKML

EINSATZGEBIET

Be- und Entladung von TKW, Kesselwagen oder Containern.

Top-Loading

Bottom-Loading

Chemische Prozesse bei denen die Fluide in der Schlauchleitung nicht mit der Umwelt in Kontakt kommen darf.

Nicht für aushärtende Medien und stark sedimenthaltige Medien geeignet.

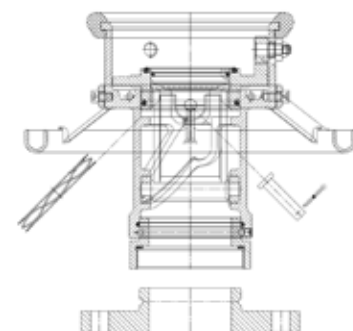
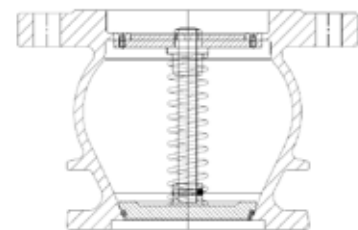



INFORMATION

Dry Disconnect Coupling

Dry disconnect couplings gasket the hose and pipe side during disconnection so that no medium can leak out.

Such safety couplings are required in applications where no medium may be released into the environment and quick couplings are prohibited. These safety couplings are available in a wide variety of designs. For this reason, the coupling

part and nut part should preferably be from the same manufacturer. This coupling is a tried and tested system. It was developed for US military use and can be found in today's STARNAK standard. This coupling opens by a 120° rotary movement after the rollers in the nut have engaged behind the web of the coupling part. The rotary movement pushes the

two valves into the coupling part. Uncoupling is achieved by turning back. The female part can only be disconnected when the valves seal.

WHY MCC?

- Fittings are always equipped with high-quality FKM gaskets.
- The body materials are made of SS 316 stainless steel
- The levers are made of break-proof materials, ergonomically shaped
- The valves have an additional face gasket that reduces drips



TECHNICAL INFORMATION

- Starnak standard
- Thread: ISO 228 flat sealing (Dimensions thread length or thread depth comparable to DIN EN 14420-5)
- Flange like EN 1092
- Working pressure: -0,8 to 25 bar with 65°C
- Material:
 - Coupling: stainless steel
 - Gasket: FKMI

AREA OF APPLICATION

Loading and unloading of trucks, tank wagons or containers.

- Top loading
- Bottom loading

Chemical processes in which the fluids in the hose line must not come into contact with the environment. Not suitable for hardening media and media with a high sediment content.

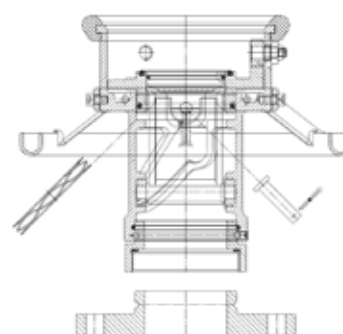
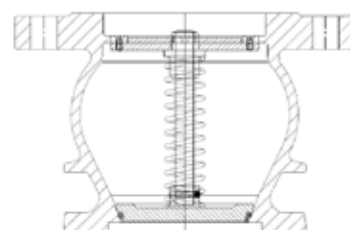



Trockenkupplung Mutterteil mit BSPP Innengewinde mit FKM Dichtung

Female dry disconnet coupling female thread - FKM gasket
 Raccord auto-obturant femelle avec taraudage femelle - Joint FKM
 Acople seco hembra con rosca hembra BSP - Junta FKM
 Część żeńska suchego sprzęgła z gwintem wewnętrznym BSPP - Uszczelka FKM
 Accoppiamento a secco femmina con filetto femmina - Guarnizione FKM

Part-No.	Material	WP	Coupling	Thread	Price
DDF200BSPF200SS	SS 1.4408	25 bar	2"	2"	
DDF300BSPF300SS	SS 1.4408	25 bar	3"	3"	
DDF400BSPF400SS	SS 1.4408	25 bar	4"	4"	



Trockenkupplung Vaterteil mit BSPP Innengewinde mit FKM Dichtung

Male dry disconnet coupling female thread - FKM gasket
 Raccord auto-obturant mâle avec taraudage femelle - Joint FKM
 Acople seco macho con rosca hembra BSP - Junta FKM
 Część męska suchego sprzęgła z gwintem wewnętrznym BSPP - Uszczelka FKM
 Accoppiamento a secco maschio con filetto femmina - Guarnizione FKM

Part-No.	Material	WP	Coupling	Thread	Price
DDM200BSPF200SS	SS 1.4408	25 bar	2"	2"	
DDM300BSPF300SS	SS 1.4408	25 bar	3"	3"	
DDM400BSPF400SS	SS 1.4408	25 bar	4"	4"	



Trockenkupplung Mutterteil mit Flansch nach EN1092 mit FKM Dichtung

Female dry disconnet coupling with flange according EN1092 - FKM gasket - FKM gasket
 Raccord auto-obturant femelle avec bride - Joint FKM
 Acople seco hembra con brida EN1092 - Junta FKM
 Suchy łącznik część żeńska z kołnierzem zgodnie z EN1092 - Uszczelka FKM
 Accoppiamento a secco femmina con flangia EN1092 - Guarnizione FKM

Part-No.	Material	WP	Coupling	Flange	Price
DDF200FL200SS	SS 1.4408	25 bar	2"	2"	
DDF300FL300SS	SS 1.4408	25 bar	3"	3"	
DDF400FL400SS	SS 1.4408	25 bar	4"	4"	

Trockenkupplung Vaterteil mit Flansch nach EN1092
mit FKM Dichtung

Male dry disconnet coupling with flange according EN1092 - FKM gasket
Raccord auto-obturant mâle avec bride EN1092 - Joint FKM
Acople seco macho con brida EN1092 - Junta FKM
Suchy łącznik część męska z kotnierzem zgodnie z EN1092 - Uszczelka FKM
Accoppiamento a secco maschio con flangia EN1092 - Guarnizione FKM



Part-No.	Material	WP	Coupling	Flange	Price
DDM200FL200SS	SS 1.4408	25 bar	2"	2"	
DDM300FL300SS	SS 1.4408	25 bar	3"	3"	
DDM400FL400SS	SS 1.4408	25 bar	4"	4"	

Trockenkupplung Mutterteil mit BSPP Innengewinde
mit FKM Dichtung

Female dry disconnet coupling with female thread - FKM gasket
Raccord auto-obturant femelle avec taraudage femelle - Joint FKM
Acople seco hembra con rosca hembra BSP - Junta FKM
Część żeńska suchego sprzęgła z gwintem wewnętrznym BSPP - Uszczelka FKM
Accoppiamento a secco femmina con filetto femmina - Guarnizione FKM



Part-No.	Material	WP	Coupling	Thread	Price
DDF200BSPF200AL	Aluminum	16 bar	2"	2"	
DDF300BSPF300AL	Aluminum	16 bar	3"	3"	
DDF400BSPF400AL	Aluminum	16 bar	4"	4"	

Trockenkupplung Vaterteil mit BSPP Innengewinde
mit FKM Dichtung

Male dry disconnet coupling with female thread - FKM gasket
Raccord auto-obturant mâle avec taraudage femelle - Joint FKM
Acople seco macho con rosca hembra BSP - Junta FKM
Część męska suchego sprzęgła z gwintem wewnętrznym BSPP - Uszczelka FKM
Accoppiamento a secco maschio con filetto femmina - Guarnizione FKM



Part-No.	Material	WP	Dimension	Thread	Price
DDM200BSPF200AL	Aluminum	16 bar	2"	2"	
DDM300BSPF300AL	Aluminum	16 bar	3"	3"	
DDM400BSPF400AL	Aluminum	16 bar	4"	4"	

INFORMATIONEN

Hebelarmaturen Kamlok



Die Kamlok-Kupplung, auch bekannt als Hebelarm-Kupplung, basiert auf der Mil A-A-59326A. Sie ist in Europa durch die DIN EN 14420-7 genormt.

Diese Schnelkkupplungen werden verwendet, um Schlauchleitungen mit Rohrleitungen zu verbinden.

Sie dienen dem Transport von Flüssigkeiten und Granulaten. MCC bietet eine zusätzliche und clevere Hebelsicherung an, um ein unbeabsichtigtes Lösen zu verhindern. Diese gleicht die Nachteile eines solchen Hebelprinzips aus.

WARUM MCC?

- Präzise und qualitativ hochwertige Fertigung (Materialstärke und verstärkte Hebel)
- Dichtung wird nicht einseitig belastet und erhöht somit die Dichtigkeit.
- Vielfältige Ausführungen (u.a. eine clevere Hebelsicherung, die ein unbeabsichtigtes Lösen des Hebels verhindert und mit einer Hand geöffnet werden kann).
- Zusätzliche Bearbeitung: Armatur ist im Kupplungsbereich nachgearbeitet, um ein Kippen des Vatterteils zu vermeiden. Hierdurch liegt das Vatterteil gleichmäßig an der Dichtung an, auch wenn ein Schlauch ein Kippmoment aufbringt.
- PFA Beschichtete Armaturen erhältlich (werden häufig verwendet, wenn Flexibilität und ein höherer Dauerbetriebstemperaturbereich erforderlich ist.)



TECHNISCHE INFORMATIONEN

- Normen: DIN EN 14420-7
- Gewinde: ISO 228 flachdichtend (Abmessungen Gewindelänge bzw. Gewindetiefe vergleichbar DIN EN 14420-5)
- Betriebsdruck: -0,8 bis 16 bar bei 65°C, Alu bis 10 bar. Eine 60 bar Variante ist verfügbar
- Werkstoffe:
 Armaturen: Messing, Edelstahl, Aluminium, Polypropylen
 Kupplungsdichtung: NBR, FKM, CSM, FEP, PTFE, Silikon
 Gewindedichtungen: PTFE, PU, FKM, EPDM, NBR, Silikon, nach EU1935/2004, FDA für Lebensmittel

EINSATZGEBIET

Diese Schnelkkupplung wird verwendet, um Schläuche untereinander oder mit Rohrleitungen zu verbinden. Sie dienen dem Transport von Flüssigkeiten und Feststoffen. Durch den Ursprung aus einer amerikanischen MIL-Norm ist sie nahezu kompatibel mit Kupplungen gleichen Typs, auch wenn sie nicht nach DIN EN 14420-7 genormt sind.

Sie wird wegen der einfachen und leichten Bedienbarkeit gerne an Be- und Entladestellen eingesetzt.

Typ C

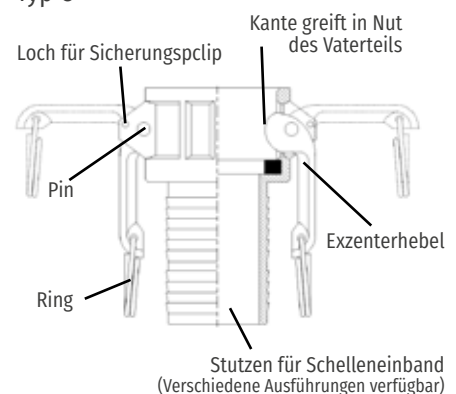

Typ E

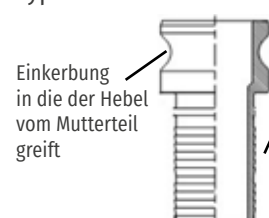



INFORMATION

Cam and groove couplings

The camlock coupling, also known as a “lever arm coupling”, is originally based on the MIL A-A-59326A. It is standardized in Europe by DIN EN 14420-7.

MCC offers an additional and clever lever lock to prevent unintentional loosening.

These quick couplings are used to connect flexible hose to each other or pipelines. They are used to transport liquids and granulates.

WHY MCC?

- Precise and high-quality manufacturing (material thickness and reinforced lever)
- Gasket is not loaded on one side and therefore increases tightness.
- Wide range of designs (including a clever lever lock that prevents unintentional release of the lever and can be opened with one hand.
- Additional machining: The fitting is reworked in the coupling area to prevent the male part from tilting. This ensures that the male part lies evenly against the seal, even if a hose applies a tilting moment.
- PFA lined couplings available (often used when flexibility and a higher continuous operating temperature range is required).



TECHNICAL INFORMATION

- Norm: DIN EN 14420-6
- Thread: ISO 228 flat sealing (dimensions thread length or thread depth comparable to DIN EN 14420-5)
- working pressure: -0.8 to 16 bar at 65°C, aluminum up to 10 bar. A 60 bar version is available
- Materials:
 Armaturen: Messing, Edelstahl, Aluminium, Polypropylen
 Kupplungsdichtung: NBR, FKM, CSM, FEP, PTFE, Silikon
 Thread Gaskets: PTFE, PU, FKM, EPDM, NBR, silicone, according to EU1935/2004, FDA for foodstuffs

AREA OF APPLICATION

This quick coupling is used to connect flexible hoses to each other or to pipelines. They are used to transport liquids and solids. Due to its origin in an American MIL standard, it is almost compatible with couplings of the same type, even if they are not standardised in accordance with DIN EN 14420-7.

It is often used on loading and unloading stations due to its simple and easy operation.

Typ C

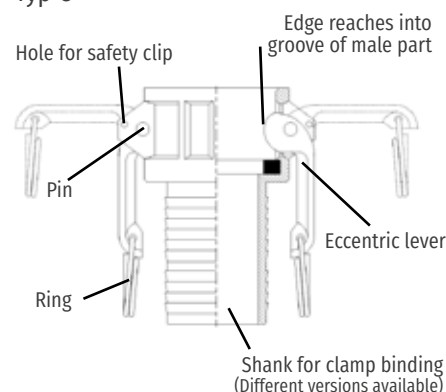

Typ E

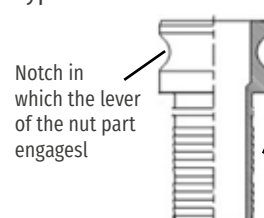



Vaterteil Typ A - MIL A-A-59326A mit BSPP Innengewinde

Male adapter type A - MIL A-A-59326A with female BSPP thread
 Adaptateur type A taraudé femelle BSPP - MIL A-A-59326A
 Camlock tipo A: acople macho - rosca hembra BSPP
 Męczyzna Typ A - MIL A-A-59326A - Wtyk z gwintem wewnętrznym BSPP
 Camlock tipo A: versione maschio filettato femmina BSPP

Part-No.	Material	WP	Dimension	Thread	Price
A050SS	SS316/CF8M	10 bar	DN15	1/2"	
A075SS	SS316/CF8M	10 bar	DN20	3/4"	
A100SS	SS316/CF8M	10 bar	DN25	1"	
A125SS	SS316/CF8M	10 bar	DN32	1 1/4"	
A150SS	SS316/CF8M	10 bar	DN40	1 1/2"	
A200SS	SS316/CF8M	10 bar	DN50	2"	
A250SS	SS316/CF8M	10 bar	DN65	2 1/2"	
A300SS	SS316/CF8M	10 bar	DN80	3"	
A400SS	SS316/CF8M	7 bar	DN100	4"	
A500SS	SS316/CF8M	5 bar	DN125	5"	
A600SS*	SS316/CF8M	5 bar	DN150	6"	



Vaterteil Typ A - MIL A-A-59326A mit NPT Innengewinde

Male adapter type A - MIL A-A-59326A with female NPT thread

Adaptateur type A taraudé femelle NPT - MIL A-A-59326A

Camlock tipo A: acople macho - rosca hembra NPT

Męczyzna Typ A - MIL A-A-59326A - Wtyk z gwintem wewnętrznym NPT

Camlock tipo A: versione maschio filettato femmina NPT



Part-No.	Material	WP	Dimension	Thread	Price
A050SS-NPT	SS316/CF8M	10 bar	DN15	1/2"	
A075SS-NPT	SS316/CF8M	10 bar	DN20	3/4"	
A100SS-NPT	SS316/CF8M	10 bar	DN25	1"	
A125SS-NPT	SS316/CF8M	10 bar	DN32	1 1/4"	
A150SS-NPT	SS316/CF8M	10 bar	DN40	1 1/2"	
A200SS-NPT	SS316/CF8M	10 bar	DN50	2"	
A250SS-NPT	SS316/CF8M	10 bar	DN65	2 1/2"	
A300SS-NPT	SS316/CF8M	10 bar	DN80	3"	
A400SS-NPT	SS316/CF8M	7 bar	DN100	4"	





Mutterteil Typ B - MIL A-A-59326A mit BSPT Außengewinde
mit NBR Dichtung

Female coupler type B - MIL A-A-59326A with male BSPT thread - NBR gasket
 Coupleur type B fileté mâle BSPT - MIL A-A-59326A - Joint NBR
 Camlock tipo B: acople hembra - rosca macho BSPT - Junta NBR
 Kobieta Typ B - MIL A-A-59326A - Gniazdo z gwintem zewnętrznym BSPT - NBR Uszczelka
 Camlock tipo B: versione femmina filettata maschio - Guarnizione NBR

Part-No.	Material	WP	Dimension	Thread	Price
B050SS2	SS316/CF8M	10 bar	DN15	1/2"	
B075SS	SS316/CF8M	10 bar	DN20	3/4"	
B100SS	SS316/CF8M	10 bar	DN25	1"	
B125SS	SS316/CF8M	10 bar	DN32	1 1/4"	
B150SS	SS316/CF8M	10 bar	DN40	1 1/2"	
B200SS	SS316/CF8M	10 bar	DN50	2"	
B250SS	SS316/CF8M	10 bar	DN65	2 1/2"	
B300SS	SS316/CF8M	10 bar	DN80	3"	
B400SS	SS316/CF8M	7 bar	DN100	4"	
B500SS	SS316/CF8M	5 bar	DN125	5"	
B600SS	SS316/CF8M	5 bar	DN150	6"	



Mutterteil Typ B - MIL A-A-59326A mit BSPT Außengewinde
Sicherheitsverschluss System Self-Lock - NBR Dichtung

Female coupler type B - MIL A-A-59326A with male BSPT thread - System Self-Lock - NBR gasket
 Coupleur type B fileté mâle BSPT - MIL A-A-59326A - Système Self-Lock - Joint NBR
 Camlock tipo B - Security: acople hembra - rosca macho BSPT - Anillas de seguridad - Junta NBR
 Kobieta Typ B - MIL A-A-59326A - Gniazdo z gwintem zewnętrznym BSPT - Samozamykacz systemowy - NBR Uszczelka
 Camlock tipo B - Security: versione femmina filettata maschio - Anello di sicurezza autobloccante - Guarnizione NBR

Part-No.	Material	WP	Dimension	Thread	Price
B200SS-SLL	SS316/CF8M	10 bar	DN50	2"	
B300SS-SLL	SS316/CF8M	10 bar	DN80	3"	
B400SS-SLL	SS316/CF8M	7 bar	DN100	4"	



Mutterteil Typ B - MIL A-A-59326A mit NPT Außengewinde mit NBR Dichtung

Female coupler type B - MIL A-A-59326A with male NPT thread - NBR gasket

Coupleur type B fileté mâle NPT - MIL A-A-59326A - Joint NBR

Camlock tipo B: acople hembra - rosca macho NPT - Junta NBR

Kobieta Typ B - MIL A-A-59326A - Gniazdo z gwintem zewnętrznym NPT - NBR Uszczelka

Camlock tipo B: versione femmina filettata maschio NPT - Guarnizione NBR



Part-No.	Material	WP	Dimension	Thread	Price
B075SS-NPT	SS316/CF8M	10 bar	DN20	3/4"	
B100SS-NPT	SS316/CF8M	10 bar	DN25	1"	
B125SS-NPT	SS316/CF8M	10 bar	DN32	1 1/4"	
B150SS-NPT	SS316/CF8M	10 bar	DN40	1 1/2"	
B200SS-NPT	SS316/CF8M	10 bar	DN50	2"	
B250SS-NPT	SS316/CF8M	10 bar	DN65	2 1/2"	
B300SS-NPT	SS316/CF8M	10 bar	DN80	3"	
B400SS-NPT	SS316/CF8M	7 bar	DN100	4"	

Mutterteil Typ B - MIL A-A-59326A mit BSPT Außengewinde

Sicherheitsverschluss System Security - NBR Dichtung

Female coupler type B - MIL A-A-59326A with male BSPT thread - Type Security Lock - NBR gasket

Coupleur Type B - MIL A-A-59326A fileté mâle BSPT - Type Autolock - Joint NBR

Camlock tipo B - Security: acople hembra - rosca macho BSPT - palancas de seguridad - Junta NBR

Kobieta Typ B - MIL A-A-59326A - Gniazdo z gwintem zewnętrznym BSPT z rączkami zabezpieczającymi - NBR Uszczelka

Camlock tipo B - Security: versione femmina filettata maschio e leve di sicurezza - Guarnizione NBR



Keine Lagerware!
No stock item!

NEW

Part-No.	Material	WP	Dimension	Thread	Price
B075SECURITY	SS316/CF8M	10 bar	DN20	3/4"	
B100SECURITY	SS316/CF8M	10 bar	DN25	1"	
B125SECURITY	SS316/CF8M	10 bar	DN32	1 1/4"	
B150SECURITY	SS316/CF8M	10 bar	DN40	1 1/2"	
B200SECURITY	SS316/CF8M	10 bar	DN50	2"	
B300SECURITY	SS316/CF8M	10 bar	DN80	3"	
B400SECURITY	SS316/CF8M	7 bar	DN100	4"	





Mutterteil Typ C - MIL A-A-59326A mit Stutzen für Schelleneinband
mit NBR Dichtung

Female coupler type C - MIL A-A-59326A with grooved hose-shank - NBR gasket

Coupleur type C douille annelée sans collerette - MIL A-A-59326A - Joint NBR

Camlock tipo C: acople hembra - espiga para manguera - Junta NBR

Kobieta Typ C - MIL A-A-59326A - Gniazdo z karbowaną końcówką do węża do mocowania opaskami - NBR Uszczelka

Camlock tipo C: versione femmina portagomma - Guarnizione NBR

Part-No.	Material	WP	Dimension	Shank	Price
C050SS2	SS316/CF8M	10 bar	DN15	13mm	
C075SS	SS316/CF8M	10 bar	DN20	21mm	
C100SS	SS316/CF8M	10 bar	DN25	27mm	
C125SS	SS316/CF8M	10 bar	DN32	34mm	
C150SS	SS316/CF8M	10 bar	DN40	40mm	
C200SS	SS316/CF8M	10 bar	DN50	51mm	
C200x150SS	SS316/CF8M	10 bar	DN50	40mm	
C250SS	SS316/CF8M	10 bar	DN65	64mm	
C300SS	SS316/CF8M	10 bar	DN80	76mm	
C400SS	SS316/CF8M	7 bar	DN100	103mm	
C500SS	SS316/CF8M	5 bar	DN125	128mm	
C600SS	SS316/CF8M	5 bar	DN150	152mm	



Mutterteil Typ C - MIL A-A-59326A mit Stutzen für Schelleneinband
Sicherheitsverschluss System Self-Lock - NBR Dichtung

Female coupler type C - MIL A-A-59326A with grooved hose-shank - System Self-Lock - NBR gasket

Coupleur type C douille annelée sans collerette - MIL A-A-59326A - Système Self-Lock - Joint NBR

Camlock tipo C - Security: acople hembra - espiga con cuello de seguridad - Anillas de seguridad - Junta NBR

Kobieta Typ C - MIL A-A-59326A - Gniazdo z karbowaną końcówką do węża do mocowania opaskami - Samozamykacz systemowy - NBR Uszczelka

Camlock femmina tipo C - MIL A-A 59326A - Anello di sicurezza autobloccante - Guarnizione NBR

Part-No.	Material	WP	Dimension	Shank	Price
C200SS-SLL	SS316/CF8M	10 bar	DN50	51mm	
C300SS-SLL	SS316/CF8M	10 bar	DN80	76mm	
C400SS-SLL	SS316/CF8M	7 bar	DN100	103mm	



Mutterteil Typ C - MIL A-A-59326A - Stutzen für Schelleneinband

Sicherheitsverschluss System Security - NBR Dichtung

Female coupler type C - MIL A-A-59326A with grooved hose-shank - Type Security Lock - NBR gasket

Coupleur Type C - MIL A-A-59326A douille annelée sans collerette - Type Autolock - Joint NBR

Camlock tipo C - Security: acople hembra - espiga para manguera - palancas de seguridad - Junta NBR

Kobieta Typ C - MIL A-A-59326A - Gniazdo z karbowaną końcówką do węża do mocowania opaskami z rączkami zabezpieczającymi - NBR Uszczelka

Camlock tipo C - Security: versione femmina portagomma e leve di sicurezza - Guarnizione NBR

**NEW**

Part-No.	Material	WP	Dimension	Shank	Price
C075SECURITY	SS316/CF8M	10 bar	DN19	21mm	
C100SECURITY	SS316/CF8M	10 bar	DN25	27mm	
C125SECURITY	SS316/CF8M	10 bar	DN32	34mm	
C150SECURITY	SS316/CF8M	10 bar	DN40	40mm	
C200SECURITY	SS316/CF8M	10 bar	DN50	51mm	
C300SECURITY	SS316/CF8M	10 bar	DN80	76mm	
C400SECURITY	SS316/CF8M	7 bar	DN100	103mm	

Keine Lagerware!
No stock item!



Mutterteil Typ D - MIL A-A-59326A mit BSPP Innengewinde
mit NBR Dichtung

Female coupler type D - MIL A-A-59326A with female BSPP thread - NBR gasket
 Coupleur type D taraudé femelle BSPP - MIL A-A-59326A - Joint NBR
 Camlock tipo D: acople hembra - rosca hembra BSPP - Junta NBR
 Kobieta Typ D - MIL A-A-59326A - Gniazdo z gwintem wewnętrznym BSPP - NBR Uszczelka
 Camlock tipo D: versione femmina filettato femmina BSPP - Guarnizione NBR

Part-No.	Material	WP	Dimension	Thread	Price
D050SS2	SS316/CF8M	10 bar	DN15	1/2"	
D075SS	SS316/CF8M	10 bar	DN20	3/4"	
D100SS	SS316/CF8M	10 bar	DN25	1"	
D125SS	SS316/CF8M	10 bar	DN32	1 1/4"	
D150SS	SS316/CF8M	10 bar	DN40	1 1/2"	
D200SS	SS316/CF8M	10 bar	DN50	2"	
D250SS	SS316/CF8M	10 bar	DN65	2 1/2"	
D300SS	SS316/CF8M	10 bar	DN80	3"	
D400SS	SS316/CF8M	7 bar	DN100	4"	
D500SS	SS316/CF8M	5 bar	DN125	5"	
D600SS	SS316/CF8M	5 bar	DN150	6"	



Mutterteil Typ D - MIL A-A-59326A mit BSPP Innengewinde
Sicherheitsverschluss System Self-Lock - NBR Dichtung

Female coupler type D - MIL A-A-59326A with female BSPP thread - System Self-Lock - NBR gasket
 Coupleur type D taraudé femelle BSPP - MIL A-A-59326A - Système Self-Lock Joint NBR
 Camlock tipo D - Security: acople hembra - rosca hembra BSPP - Anillas de seguridad - Junta NBR
 Kobieta Typ D - MIL A-A-59326A - Gniazdo z gwintem wewnętrznym BSPP - Samozamykacz systemowy - NBR Uszczelka
 Camlock tipo D - MIL A-A 59326A - versione femmina con filettatura femmina BSPP - Anello di sicurezza autobloc-
 cante - Guarnizione NBR

Part-No.	Material	WP	Dimension	Thread	Price
D200SS-SLL	SS316/CF8M	10 bar	DN50	2"	
D300SS-SLL	SS316/CF8M	10 bar	DN80	3"	
D400SS-SLL	SS316/CF8M	7 bar	DN100	4"	



Mutterteil Typ D - MIL A-A-59326A mit NPT Innengewinde

mit NBR Dichtung

Female coupler type D - MIL A-A-59326A with female NPT thread - NBR gasket

Coupleur type D taraudé femelle NPT - MIL A-A-59326A - Joint NBR

Camlock tipo D: acople hembra - rosca hembra NPT - Junta NBR

Kobieta Typ D - MIL A-A-59326A - Gniazdo z gwintem wewnętrznym NPT - NBR Uszczelka

Camlock tipo D: versione femmina filettato femmina NPT - Guarnizione NBR



Part-No.	Material	WP	Dimension	Thread	Price
D075SS-NPT	SS316/CF8M	10 bar	DN20	3/4"	
D100SS-NPT	SS316/CF8M	10 bar	DN25	1"	
D125SS-NPT	SS316/CF8M	10 bar	DN32	1 1/4"	
D150SS-NPT	SS316/CF8M	10 bar	DN40	1 1/2"	
D200SS-NPT	SS316/CF8M	10 bar	DN50	2"	
D250SS-NPT	SS316/CF8M	10 bar	DN65	2 1/2"	
D300SS-NPT	SS316/CF8M	10 bar	DN80	3"	
D400SS-NPT	SS316/CF8M	7 bar	DN100	4"	

Mutterteil Typ D - MIL A-A-59326A mit BSPP Innengewinde

Sicherheitsverschluss System Security - NBR Dichtung

Female coupler type D - MIL A-A-59326A with female BSPP thread - Type Security Lock - NBR gasket

Coupleur Type D- MIL A-A-59326A taraudé femelle BSPP - Type Autolock - Joint NBR

Camlock tipo D - Security: acople hembra - rosca hembra BSPP - palancas de seguridad - Junta NBR

Kobieta Typ D - MIL A-A-59326A - Gniazdo z gwintem wewnętrznym BSPP z rączkami zabezpieczającymi - NBR Uszczelka

Camlock tipo D - Security: versione femmina filettato femmina BSPP e leve di sicurezza - Guarnizione NBR

Keine Lagerware!
No stock item!**NEW**

Part-No.	Material	WP	Dimension	Thread	Price
D075SECURITY	SS316/CF8M	10 bar	DN20	3/4"	
D100SECURITY	SS316/CF8M	10 bar	DN25	1"	
D125SECURITY	SS316/CF8M	10 bar	DN32	1 1/4"	
D150SECURITY	SS316/CF8M	10 bar	DN40	1 1/2"	
D200SECURITY	SS316/CF8M	10 bar	DN50	2"	
D300SECURITY	SS316/CF8M	10 bar	DN80	3"	
D400SECURITY	SS316/CF8M	7 bar	DN100	4"	





Vaterteil Typ E - MIL A-A-59326A mit Stutzen für Schelleneinband

Male adapter type E - MIL A-A-59326A with grooved hose-shank
 Adaptateur type E douille annelée sans collerette - MIL A-A-59326A
 Camlock tipo E: acople macho - espiga para manguera
 Męczyzna Typ E - MIL A-A-59326A - Wtyk z karbowaną końcówką do węża do mocowania opaskami
 Camlock tipo E: versione maschio portagomma

Part-No.	Material	WP	Dimension	Shank	Price
E050SS	SS316/CF8M	10 bar	DN15	13mm	
E075SS	SS316/CF8M	10 bar	DN20	21mm	
E100SS	SS316/CF8M	10 bar	DN25	27mm	
E125SS	SS316/CF8M	10 bar	DN32	34mm	
E150SS	SS316/CF8M	10 bar	DN40	40mm	
E200SS	SS316/CF8M	10 bar	DN50	51mm	
E250SS	SS316/CF8M	10 bar	DN65	64mm	
E300SS	SS316/CF8M	10 bar	DN80	76mm	
E400SS	SS316/CF8M	7 bar	DN100	103mm	
E500SS	SS316/CF8M	5 bar	DN125	128mm	
E600SS	SS316/CF8M	5 bar	DN150	152mm	



Vaterteil Typ F - MIL A-A-59326A mit BSPT Außengewinde

Male adapter type F - MIL A-A-59326A with male BSPT thread

Adaptateur type F fileté mâle BSPT - MIL A-A-59326A

Camlock tipo F: acople macho - rosca macho BSPT

Męczyzna Typ F - MIL A-A-59326A - Wtyk z gwintem zewnętrznym BSPT

Camlock tipo F: versione maschio filettato maschio BSPT



Part-No.	Material	WP	Dimension	Thread	Price
F050SS	SS316/CF8M	10 bar	DN15	1/2"	
F075SS	SS316/CF8M	10 bar	DN20	3/4"	
F100SS	SS316/CF8M	10 bar	DN25	1"	
F125SS	SS316/CF8M	10 bar	DN32	1 1/4"	
F150SS	SS316/CF8M	10 bar	DN40	1 1/2"	
F200SS	SS316/CF8M	10 bar	DN50	2"	
F250SS	SS316/CF8M	10 bar	DN65	2 1/2"	
F300SS	SS316/CF8M	10 bar	DN80	3"	
F400SS	SS316/CF8M	7 bar	DN100	4"	
F500SS	SS316/CF8M	5 bar	DN125	5"	
F600SS	SS316/CF8M	5 bar	DN150	6"	

Vaterteil Typ F - MIL A-A-59326A mit NPT Außengewinde

Male adapter type F - MIL A-A-59326A with male NPT thread

Adaptateur type F fileté mâle NPT - MIL A-A-59326A

Camlock tipo F: acople macho - rosca macho NPT

Męczyzna Typ F - MIL A-A-59326A - Wtyk z gwintem zewnętrznym NPT

Camlock tipo F: versione maschio filettato maschio NPT



Part-No.	Material	WP	Dimension	Thread	Price
F100SS-NPT	SS316/CF8M	10 bar	DN25	1"	
F125SS-NPT	SS316/CF8M	10 bar	DN32	1 1/4"	
F150SS-NPT	SS316/CF8M	10 bar	DN40	1 1/2"	
F200SS-NPT	SS316/CF8M	10 bar	DN50	2"	
F250SS-NPT	SS316/CF8M	10 bar	DN65	2 1/2"	
F300SS-NPT	SS316/CF8M	10 bar	DN80	3"	
F400SS-NPT	SS316/CF8M	7 bar	DN100	4"	





Kappe Typ DC - MIL A-A-59326A

mit NBR Dichtung

- Dust cap type DC - MIL A-A-59326A - NBR gasket
- Bouchon adaptateur type DC - MIL A-A-59326A - Joint NBR
- Camlock tipo DC: tapón hembra - Junta NBR
- Zaślepka wtyku Typ DC - MIL A-A-59326A - NBR Uszczelka
- Camlock tipo DC: tappo femmina - Guarnizione NBR

Part-No.	Material	WP	Dimension	Price
DC050SS2	SS316/CF8M	10 bar	DN15	
DC075SS	SS316/CF8M	10 bar	DN20	
DC100SS	SS316/CF8M	10 bar	DN25	
DC125SS	SS316/CF8M	10 bar	DN32	
DC150SS	SS316/CF8M	10 bar	DN40	
DC200SS	SS316/CF8M	10 bar	DN50	
DC250SS	SS316/CF8M	10 bar	DN65	
DC300SS	SS316/CF8M	10 bar	DN80	
DC400SS	SS316/CF8M	7 bar	DN100	
DC500SS	SS316/CF8M	5 bar	DN125	
DC600SS	SS316/CF8M	5 bar	DN150	



Kappe Typ DC nach MIL A-A-59326A

Sicherheitsverschluss System Self-Lock - NBR Dichtung

- Dust cap type DC - MIL A-A-59326A - System Self-Lock - NBR gasket
- Bouchon coupleur type DC -MIL A-A-59326A - Système Self-Lock - Joint NBR
- Camlock tipo DC - Security: Tapón hembra - Anillas de seguridad - Junta NBR
- Zaślepka wtyku Typ DC - MIL A-A-59326A - Samozamykacz systemowy - NBR Uszczelka
- Tappo Camlock tipo DC - MIL A-A-59326A - Anello di sicurezza autobloccante- Guarnizione NBR

Part-No.	Material	WP	Dimension	Price
DC200SS-SLL	SS316/CF8M	10 bar	DN50	
DC300SS-SLL	SS316/CF8M	10 bar	DN80	
DC400SS-SLL	SS316/CF8M	7 bar	DN100	



Kappe Typ DC - MIL A-A-59326A

Sicherheitsverschluss System Security - NBR Dichtung

Dust cap type DC - MIL A-A-59326A - Type Security Lock - NBR gasket

Bouchon coupleur type DC - MIL A-A-59326A - Type Autolock - Joint NBR

Camlock tipo DC - Security: tapón hembra - palancas de seguridad - Junta NBR

Zaślepka wtyku Typ DC - MIL A-A-59326A - z rączkami zabezpieczającymi - NBR Uszczelka

Camlock tipo DC - Security: tappo femmina e leve di sicurezza - Guarnizione NBR

Keine Lagerware!
No stock item!**NEW**

SCHWELLKUPPLUNGEN

Part-No.	Material	WP	Dimension	Price
DC100SECURITY	SS316/CF8M	10 bar	DN25	
DC125SECURITY	SS316/CF8M	10 bar	DN32	
DC150SECURITY	SS316/CF8M	10 bar	DN40	
DC200SECURITY	SS316/CF8M	10 bar	DN50	
DC300SECURITY	SS316/CF8M	10 bar	DN80	
DC400SECURITY	SS316/CF8M	7 bar	DN100	

Stopfen Typ DP - MIL A-A-59326A

Dust plug type DP - MIL A-A-59326A

Bouchon adaptateur type DP - MIL A-A-59326A

Camlock tipo DP: tapón macho

Zaślepka gniazda Typ DP - MIL A-A-59326A

Camlock tipo DP: tappo maschio



Part-No.	Material	WP	Dimension	Price
DP050SS	SS316/CF8M	10 bar	DN15	
DP075SS	SS316/CF8M	10 bar	DN20	
DP100SS	SS316/CF8M	10 bar	DN25	
DP125SS	SS316/CF8M	10 bar	DN32	
DP150SS	SS316/CF8M	10 bar	DN40	
DP200SS	SS316/CF8M	10 bar	DN50	
DP250SS	SS316/CF8M	10 bar	DN65	
DP300SS	SS316/CF8M	10 bar	DN80	
DP400SS	SS316/CF8M	7 bar	DN100	
DP500SS	SS316/CF8M	5 bar	DN125	
DP600SS	SS316/CF8M	5 bar	DN150	





Vaterteil - Kupplung - MIL A-A-59326A mit Anschweißende (BW)

Male - butweld camlock - MIL A-A-59326A
 Adaptateur mâle à souder - MIL A-A-59326A
 Camlock tipo AW: acople macho - para soldar
 Mężczyzna - MIL A-A-59326A - Wtyk z końcówką do wspaniania
 Camlock maschio a saldare MIL A-A 59326A

Part-No.	Material	WP	Dimension	BW (IDxOD)	Price
F050SSBW	SS316/CF8M	10 bar	DN15	14,4 x 21,3	
F075SSBW	SS316/CF8M	10 bar	DN20	20 x 26,7	
F100SSBW	SS316/CF8M	10 bar	DN25	26 x 33,4	
F125SSBW	SS316/CF8M	10 bar	DN32	34 x 42,2	
F150SSBW	SS316/CF8M	10 bar	DN40	39 x 48,3	
F200SSBW	SS316/CF8M	10 bar	DN50	51 x 60,3	
F250SSBW	SS316/CF8M	10 bar	DN65	66,5 x 76,1	
F300SSBW	SS316/CF8M	10 bar	DN80	78 x 88,9	
F400SSBW	SS316/CF8M	7 bar	DN100	102 x 114,3	
F500SSBW	SS316/CF8M	5 bar	DN125	129,8 x 141,3	
F600SSBW	SS316/CF8M	5 bar	DN150	150,8 x 168,3	



Vaterteil - Kupplung - MIL A-A-59326A auf Festflansch

Male flanged camlock coupling - MIL A-A-59326A
 Raccord à cames adaptateur sur bride PN 10/16 en inox - MIL A-A-59326A
 Camlock tipo LAS: acople macho con brida fija
 Mężczyzna - MIL A-A-59326A - Wtyk z przyłączem kołnierowym
 Camlock tipo LAS: versione maschio flangiato

Part-No.	Material	WP	Dimension	Flange	Price
100ANP	SS316/CF8M	10 bar	DN25	PN 10/16	
125ANP	SS316/CF8M	10 bar	DN32	PN 10/16	
150ANP	SS316/CF8M	10 bar	DN40	PN 10/16	
200ANP	SS316/CF8M	10 bar	DN50	PN 10/16	
250ANP	SS316/CF8M	10 bar	DN65	PN 10/16	
300ANP	SS316/CF8M	10 bar	DN80	PN 10/16	
400ANP	SS316/CF8M	10 bar	DN100	PN 10/16	



Mutterteil - Kupplung - MIL A-A-59326A mit Anschweißende (BW) mit NBR Dichtung

Female - butweld camlock - MIL A-A-59326A - NBR gasket

Coupleur femelle à souder - MIL A-A-59326A - Joint NBR

Camlock tipo BW: acople hembra - para soldar- Junta NBR

Kobieta - MIL A-A-59326A - Gniazdo z końcówką do wstawiania -NBR Uszczelka

Camlock femmina a saldare MIL A-A 59326A - Guarnizione NBR



Part-No.	Material	WP	Dimension	BW (IDxOD)	Price
B050SSBW	SS316/CF8M	10 bar	DN15	14,4 x 21,3	
B075SSBW	SS316/CF8M	10 bar	DN20	20 x 26,7	
B100SSBW	SS316/CF8M	10 bar	DN25	26 x 33,4	
B125SSBW	SS316/CF8M	10 bar	DN32	34 x 42,2	
B150SSBW	SS316/CF8M	10 bar	DN40	39 x 48,3	
B200SSBW	SS316/CF8M	10 bar	DN50	51 x 60,3	
B250SSBW	SS316/CF8M	10 bar	DN65	66,5 x 76,1	
B300SSBW	SS316/CF8M	10 bar	DN80	78 x 88,9	
B400SSBW	SS316/CF8M	7 bar	DN100	102 x 114,3	
B500SSBW	SS316/CF8M	5 bar	DN125	129,8 x 141,3	
B600SSBW	SS316/CF8M	5 bar	DN150	150,8 x 168,3	

Mutterteil- Kupplung - MIL A-A-59326A auf Festflansch mit NBR Dichtung

Female flanged camlock coupling - MIL A-A-59326A -NBR gasket

Coupleur femelle sur bride PN 10/16 en inox - Joint NBR

Camlock tipo LBS: acople hembra con brida fija - Junta NBR

Kobieta - MIL A-A-59326A - Gniazdo z przyłączem kotłowym - NBR Uszczelka

Camlock tipo LBS: versione femmina flangiato



Part-No.	Material	WP	Dimension	Flange	Price
100CNP	SS316/CF8M	10 bar	DN25	PN 10/16	
125CNP	SS316/CF8M	10 bar	DN32	PN 10/16	
150CNP	SS316/CF8M	10 bar	DN40	PN 10/16	
200CNP	SS316/CF8M	10 bar	DN50	PN 10/16	
250CNP	SS316/CF8M	10 bar	DN65	PN 10/16	
300CNP	SS316/CF8M	10 bar	DN80	PN 10/16	
400CNP	SS316/CF8M	10 bar	DN100	PN 10/16	



Kamlok Adapter Stücke - MIL A-A-59326A

weitere Nennweiten und Kombinationen auf Anfrage

- Camlock adapter - MIL A-A-59326A - Other sizes and adapter available
- Raccords à cames - MIL A-A-59326A - Autres largeurs nominales et combinaisons disponibles
- Adaptador camlock - MIL A-A-59326A - Otras medidas y adaptadores disponibles
- Camlock Adapter - MIL A-A-59326A - Inne rozmiary i adaptory dostępne
- Adattatore camlock - MIL A-A- 59326A - Altre dimensioni e adattatori disponibili



Typ A-A



Typ D-A

Part-No.	Material	Typ	WP	DN1	DN2	Price
AA100100SS	SS316/CF8M	A-A	10 bar	DN25	DN25	
AA200200SS	SS316/CF8M	A-A	10 bar	DN50	DN50	
AA300300SS	SS316/CF8M	A-A	10 bar	DN80	DN80	
DA300200SS	SS316/CF8M	D-A	10 bar	DN80	DN50	
DA400300SS	SS316/CF8M	D-A	10 bar	DN100	DN80	

Vaterteil Typ A - EN14420-7 mit BSPP Innengewinde - flachdichtend mit PTFE Gewindedichtung

- Male adapter type A - EN14420-7 with female BSPP thread - flat sealed - PTFE thread gasket
- Adaptateur taraudé femelle - EN14420-7 - Joint de filetage PTFE
- Camlock tipo A - DIN: acople macho - rosca hembra BSPP - Junta rosca PTFE
- Męczyzna Typ A zgodnie EN14420-7 - Wtyk z gwintem wewnętrznym BSPP uszczelnienie płaskie - Uszczelka gwintowana
- Camlock tipo A - DIN: versione maschio filettato femmina BSPP - Guarnizione filettato PTFE



Part-No.	Material	WP	Dimension	Thread	Price
A075DINSS	SS 1.4408	10 bar	DN19	3/4"	
A100DINSS	SS 1.4408	10 bar	DN25	1"	
A125DINSS	SS 1.4408	10 bar	DN32	1 1/4"	
A150DINSS	SS 1.4408	10 bar	DN40	1 1/2"	
A200DINSS	SS 1.4408	10 bar	DN50	2"	
A250DINSS	SS 1.4408	10 bar	DN65	2 1/2"	
A300DINSS	SS 1.4408	10 bar	DN80	3"	
A400DINSS	SS 1.4408	7 bar	DN100	4"	



Vaterteil Typ A - EN14420-7 mit BSPP Innengewinde - flachdichtend

PFA ausgekleidet

Male adapter type A - EN14420-7 with female BSPP thread - flat sealed - PFA coated

Adaptateur taraudé femelle - EN14420-7 - Revêtu de PFA

Camlock tipo A - DIN: acople macho - rosca hembra BSPP - Recubierto de PFA

Męczyzna Typ A zgodnie EN14420-7 - Wtyk z gwintem wewnętrznym BSPP uszczelnienie płaskie - Z powłoką PFA

Camlock tipo A - DIN: versione maschio filettato femmina BSPP - Rivestimento in PFA

NEW

Part-No.	Material	WP	Dimension	Shank	Price
A100DINSSPFA-W	SS 1.4408 PFA white coated	25 bar	DN25	1"	
A125DINSSPFA-W	SS 1.4408 PFA white coated	25 bar	DN32	1 1/4"	
A150DINSSPFA-W	SS 1.4408 PFA white coated	25 bar	DN40	1 1/2"	
A200DINSSPFA-W	SS 1.4408 PFA white coated	25 bar	DN50	2"	
A250DINSSPFA-W	SS 1.4408 PFA white coated	25 bar	DN65	2 1/2"	
A300DINSSPFA-W	SS 1.4408 PFA white coated	25 bar	DN80	3"	
A100DINSSPFA-B	SS 1.4408 PFA black coated	25 bar	DN25	1"	
A125DINSSPFA-B	SS 1.4408 PFA black coated	25 bar	DN32	1 1/4"	
A150DINSSPFA-B	SS 1.4408 PFA black coated	25 bar	DN40	1 1/2"	
A200DINSSPFA-B	SS 1.4408 PFA black coated	25 bar	DN50	2"	
A250DINSSPFA-B	SS 1.4408 PFA black coated	25 bar	DN65	2 1/2"	
A300DINSSPFA-B	SS 1.4408 PFA black coated	25 bar	DN80	3"	



CONDUCTIVE



Mutterteil Typ C - EN 14420-7 - mit glattem Stutzen und Sicherungsbund
mit NBR Dichtung

Female coupler type C - EN 14420-7 - with smooth shank and collar - NBR gasket

Coupleur Type C - Douille lisse et collerette - EN 14420-7- Joint NBR

Camlock tipo C - DIN: acople hembra - espiga lisa y cuello de seguridad - Junta NBR

Kobieta Typ C zgodnie EN14420-7 - Gniazdo z gładką końcówką do węża pod obejmę skorupową - NBR Uszczelka

Camlock tipo C - DIN: versione femmina portagomma liscio e collare di sicurezza - Guarnizione NBR

Part-No.	Material	WP	Dimension	Shank	Price
C075DINSS	SS 1.4408	16 bar	DN19	19mm	
C100DINSS	SS 1.4408	16 bar	DN25	25mm	
C125DINSS	SS 1.4408	16 bar	DN32	32mm	
C150DINSS	SS 1.4408	16 bar	DN40	38mm	
C200DINSS	SS 1.4408	16 bar	DN50	50mm	
C250DINSS	SS 1.4408	16 bar	DN65	63mm	
C300DINSS	SS 1.4408	16 bar	DN80	75mm	
C400DINSS	SS 1.4408	16 bar	DN100	100mm	



Mutterteil Typ C - EN 14420-7 - mit gerilltem Stutzen und Sicherungsbund
mit NBR Dichtung

Female coupler type C - EN 14420-7 - with serrated shank and collar - NBR gasket

Coupleur type C - EN 14420-7 - Douille annelée et collerette - Joint NBR

Camlock tipo C - DIN: acople hembra - espiga dentada y cuello de seguridad - Junta NBR

Kobieta Typ C - EN 14420-7 - Gniazdo z karbowaną końcówką do węża pod obejmę skorupową - NBR Uszczelka

Camlock tipo C: versione femmina portagomma e collare di sicurezza - Guarnizione NBR

Part-No.	Material	WP	Dimension	Shank	Price
C075DINSS-R	SS 1.4408	16 bar	DN19	19mm	
C100DINSS-R	SS 1.4408	16 bar	DN25	25mm	
C125DINSS-R	SS 1.4408	16 bar	DN32	32mm	
C150DINSS-R	SS 1.4408	16 bar	DN40	38mm	
C200DINSS-R	SS 1.4408	16 bar	DN50	50mm	
C250DINSS-R	SS 1.4408	16 bar	DN65	63mm	
C300DINSS-R	SS 1.4408	16 bar	DN80	75mm	
C400DINSS-R	SS 1.4408	16 bar	DN100	100mm	



Mutterteil Typ C - EN 14420-7 - mit glattem Stutzen und Sicherungsbund

Sicherheitsverschluss System Self-Lock - NBR Dichtung

Female coupler type C - EN 14420-7 with smooth hose-shank - System Self-Lock - NBR gasket

Coupleur type C - Douille lisse et collerette - EN 14420-7 - Système Self-Lock - Joint NBR

Camlock hembra tipo C - EN 14420 - 7 con espiga lisa - Anillas de seguridad -Junta NBR

Kobieta Typ C zgodnie EN14420-7 - Gniazdo z karbowaną końcówką do węża do mocowania opaskami - Samozamykacz systemowy - NBR Uszczelka

Camlock femmina tipo C-EN 14420-7 - Sistema autobloccante - Guarnizione NBR



Part-No.	Material	WP	Dimension	Shank	Price
C100DINSS-SL	SS 1.4408	16 bar	DN25	25mm	
C125DINSS-SL	SS 1.4408	16 bar	DN32	32mm	
C150DINSS-SL	SS 1.4408	16 bar	DN40	38mm	
C200DINSS-SL	SS 1.4408	16 bar	DN50	50mm	
C250DINSS-SL	SS 1.4408	16 bar	DN65	63mm	
C300DINSS-SL	SS 1.4408	16 bar	DN80	75mm	
C400DINSS-SL	SS 1.4408	16 bar	DN100	100mm	

Mutterteil Typ C - EN 14420-7 - mit gerilltem Stutzen und Sicherungsbund

Sicherheitsverschluss System Self-Lock - NBR Dichtung

Female coupler type C - EN 14420-7 with serrated hose-shank - System Self-Lock - NBR gasket

Coupleur type C - EN 14420-7 - Douille annelée et collerette - Système Self-Lock - Joint NBR

Camlock tipo C - DIN: acople hembra - espiga dentada y cuello de seguridad - Anillas de seguridad -Junta NBR

Kobieta Typ C - EN 14420-7 - Gniazdo z karbowaną końcówką do węża pod obejmę skorupową - Samozamykacz systemowy - NBR Uszczelka

Camlock femmina tipo C-EN 14420-7 - Sistema autobloccante - Guarnizione NBR



Part-No.	Material	WP	Dimension	Shank	Price
C150DINSS-R-SL	SS 1.4408	16 bar	DN40	38mm	
C200DINSS-R-SL	SS 1.4408	16 bar	DN50	50mm	





Mutterteil Typ C - EN 14420-7 - mit glattem Stutzen und Sicherungsbund

Sicherheitsverschluss System Security - NBR Dichtung

Female coupler type C - EN 14420-7 with smooth hose-shank - Type Security Lock - NBR gasket

Coupleur type C - Douille lisse et colerette - EN 14420-7 - Type Autolock - Joint NBR

Camlock tipo C security-DIN: acople hembra - espiga lisa con cuello de seguridad - palancas de seguridad -Junta NBR

Kobieta Typ C zgodnie EN14420-7 - Gniazdo z gładką końcówką do węża pod oobojmę skorupową i z rączkami zabezpieczającymi - NBR Uszczelka

Camlock tipo C security - DIN: versione femmina portagomma e leve di sicurezza - Guarnizione NBR

Keine Lagerware!
No stock item!

NEW

Part-No.	Material	WP	Dimension	Shank	Price
C075SECURITY-DIN	SS 1.4408	16 bar	DN19	19mm	
C100SECURITY-DIN	SS 1.4408	16 bar	DN25	25mm	
C125SECURITY-DIN	SS 1.4408	16 bar	DN32	32mm	
C150SECURITY-DIN	SS 1.4408	16 bar	DN40	38mm	
C200SECURITY-DIN	SS 1.4408	16 bar	DN50	50mm	
C300SECURITY-DIN	SS 1.4408	16 bar	DN80	75mm	
C400SECURITY-DIN	SS 1.4408	16 bar	DN100	100mm	



Mutterteil Typ C - EN14420-7 mit gerilltem Schlauchstutzen und Sicherungsbund

PFA ausgekleidet - FKM Dichtung

Female coupler type C - EN 14420-7 - with serrated shank and collar - PFA coated - FKM gasket

Coupleur type C - Douille annelée et collerette - EN 14420-7 - Revêtu de PFA - Joint FKM

Camlock tipo C - DIN: acople hembra - espiga dentada y cuello de seguridad - Recubierto de PFA - Junta FKM

Kobieta Typ C zgodnie EN14420-7 - Gniazdo z karbowaną końcówką do węża pod obejmę skorupową - Z powłoką PFA - FKM Uszczelka

Camlock tipo C - DIN: Portagomma a resca versione femmina - Rivestimento in PFA - Guarnizione FKM

NEW

Part-No.	Material	WP	Dimension	Shank	Price
C100DINSSPFA-W	SS 1.4408 PFA white coated	25 bar	DN25	25mm	
C125DINSSPFA-W	SS 1.4408 PFA white coated	25 bar	DN32	32mm	
C150DINSSPFA-W	SS 1.4408 PFA white coated	25 bar	DN40	38mm	
C200DINSSPFA-W	SS 1.4408 PFA white coated	25 bar	DN50	50mm	
C250DINSSPFA-W	SS 1.4408 PFA white coated	25 bar	DN65	63mm	
C300DINSSPFA-W	SS 1.4408 PFA white coated	25 bar	DN80	75mm	
C100DINSSPFA-B	SS 1.4408 PFA black coated	25 bar	DN25	25mm	
C125DINSSPFA-B	SS 1.4408 PFA black coated	25 bar	DN32	32mm	
C150DINSSPFA-B	SS 1.4408 PFA black coated	25 bar	DN40	38mm	
C200DINSSPFA-B	SS 1.4408 PFA black coated	25 bar	DN50	50mm	
C250DINSSPFA-B	SS 1.4408 PFA black coated	25 bar	DN65	63mm	
C300DINSSPFA-B	SS 1.4408 PFA black coated	25 bar	DN80	75mm	





Mutterteil Typ D - EN14420-7 - BSPP Innengewinde flachdichtend

NBR Dichtung, PTFE Gewindedichtung

Female coupler type D - EN14420-7 with female BSPP thread - NBR gasket + PTFE thread gasket

Coupleur type D taraudé femelle BSPP - EN14420-7 Joint NBR + Joint de filetage PTFE

Camlock tipo D - DIN: acople hembra - rosca hembra BSPP - Junta NBR + Junta rosca PTFE

Kobieta Typ D - EN14420-7 - Gniazdo z gwintem wewnętrznym BSPP - NBR Uszczelka + Uszczelka gwintowana

Camlock tipo D - DIN: versione femmina filettato femmina BSPP - Guarnizione PTFE

Part-No.	Material	WP	Dimension	Thread	Price
D075DINSS	SS 1.4408	16 bar	DN19	3/4"	
D100DINSS	SS 1.4408	16 bar	DN25	1"	
D125DINSS	SS 1.4408	16 bar	DN32	1 1/4"	
D150DINSS	SS 1.4408	16 bar	DN40	1 1/2"	
D200DINSS	SS 1.4408	16 bar	DN50	2"	
D250DINSS	SS 1.4408	16 bar	DN65	2 1/2"	
D300DINSS	SS 1.4408	16 bar	DN80	3"	
D400DINSS	SS 1.4408	16 bar	DN100	4"	



Mutterteil Typ D - EN 14420-7 - BSPP IG Sicherheitsverschluss System Self-Lock

mit NBR Dichtung, PTFE Gewindedichtung

Female coupler type D - EN 14420-7 with female BSPP thread - System Self-Lock - NBR gasket + PTFE thread gasket

Coupleur type D - EN 14420-7 taraudé femelle BSPP - Système Self-Lock - Joint NBR + Joint de filetage PTFE

Camlock tipo D security - DIN: acople hembra - rosca hembra BSPP - Anillas de seguridad - Junta NBR + Junta rosca PTFE

Kobieta Typ D zgodnie EN14420-7 - Gniazdo z gwintem wewnętrznym BSPP z płaską uszczelką i z Samozamykacz systemowy - NBR Uszczelka + Uszczelka gwintowana

Camlock tipo D security - DIN: versione femmina filettato femmina BSPP Sistema autobloccante - Guarnizione NBR + Guarnizione filettato PTFE

Part-No.	Material	WP	Dimension	Thread	Price
D100DINSS-SL	SS 1.4408	16 bar	DN25	1"	
D125DINSS-SL	SS 1.4408	16 bar	DN32	1 1/4"	
D150DINSS-SL	SS 1.4408	16 bar	DN40	1 1/2"	
D200DINSS-SL	SS 1.4408	16 bar	DN50	2"	
D300DINSS-SL	SS 1.4408	16 bar	DN80	3"	
D400DINSS-SL	SS 1.4408	16 bar	DN100	4"	



Mutterteil Typ D - EN 14420-7 - BSPP IG - Sicherheitsverschluss System Security

NBR Dichtung, PTFE Gewindedichtung

Female coupler type D - EN 14420-7 with female BSPP thread - Type Security Lock - NBR gasket + PTFE thread gasket

Coupleur type D - EN 14420-7 taraudé femelle BSPP - Type Autolock - Joint NBR + Joint de filetage PTFE

Camlock tipo D security - DIN: acople hembra - rosca hembra BSPP - palancas de seguridad - Junta NBR + Junta rosca PTFE

Kobieta Typ D zgodnie EN14420-7 - Gniazdo z gwintem wewnętrznym BSPP z płaską uszczelką i z rączkami zabezpieczającymi - NBR Uszczelka + Uszczelka gwintowana

Camlock tipo D security - DIN: versione femmina filettato femmina BSPP e leve di sicurezza - Guarnizione NBR + Guarnizione filettato PTFE

Keine Lagerware!
No stock item!**NEW**

Part-No.	Material	WP	Dimension	Thread	Price
D075SECURITY-DIN	SS 1.4408	16 bar	DN19	3/4"	
D100SECURITY-DIN	SS 1.4408	16 bar	DN25	1"	
D125SECURITY-DIN	SS 1.4408	16 bar	DN32	1 1/4"	
D150SECURITY-DIN	SS 1.4408	16 bar	DN40	1 1/2"	
D200SECURITY-DIN	SS 1.4408	16 bar	DN50	2"	
D300SECURITY-DIN	SS 1.4408	16 bar	DN80	3"	
D400SECURITY-DIN	SS 1.4408	16 bar	DN100	4"	



Mutterteil Typ D - EN14420-7 mit BSPP Innengewinde flachdichtend

PFA ausgekleidet - FKM Dichtung

Female coupler type D - EN14420-7 with female BSPP thread - PFA coated - FKM gasket

Coupleur type D taraudé femelle BSPP - EN14420-7 - Revêtu de PFA Joint FKM

Camlock tipo D - DIN: acople hembra - rosca hembra BSPP - Recubierto de PFA - Junta FKM

Kobieta Typ D - EN14420-7 - Gniazdo z gwintem wewnętrznym BSPP - Z powłoką PFA - FKM Uszczelka

Camlock tipo D - DIN: versione femmina filettato femmina BSPP Rivestimento in PFA - FKM

NEW



CONDUCTIVE

Part-No.	Material	WP	Dimension	Thread	Price
D100DINSSPFA-W	SS 1.4408 PFA white coated	25 bar	DN25	1"	
D125DINSSPFA-W	SS 1.4408 PFA white coated	25 bar	DN32	1 1/4"	
D150DINSSPFA-W	SS 1.4408 PFA white coated	25 bar	DN40	1 1/2"	
D200DINSSPFA-W	SS 1.4408 PFA white coated	25 bar	DN50	2"	
D250DINSSPFA-W	SS 1.4408 PFA white coated	25 bar	DN65	2 1/2"	
D300DINSSPFA-W	SS 1.4408 PFA white coated	25 bar	DN80	3"	
D100DINSSPFA-B	SS 1.4408 PFA black coated	25 bar	DN25	1"	
D125DINSSPFA-B	SS 1.4408 PFA black coated	25 bar	DN32	1 1/4"	
D150DINSSPFA-B	SS 1.4408 PFA black coated	25 bar	DN40	1 1/2"	
D200DINSSPFA-B	SS 1.4408 PFA black coated	25 bar	DN50	2"	
D250DINSSPFA-B	SS 1.4408 PFA black coated	25 bar	DN65	2 1/2"	
D300DINSSPFA-B	SS 1.4408 PFA black coated	25 bar	DN80	3"	



Vaterteil Typ E - EN14420-7 mit glattem Schlauchstutzen und Sicherungsbund

Male adapter type E - EN 14420-7 with smooth shank and collar

Adaptateur type E - Douille lisse et collerette - EN 14420-7

Camlock tipo E - DIN: acople macho - espiga lisa y cuello de seguridad

Mężczyzna Typ E zgodnie EN14420-7 - Wtyk z gładką końcówką do węża pod obejmę skorupową

Camlock tipo E - DIN: versione maschio portagomma liscio



Part-No.	Material	WP	Dimension	Shank	Price
E075DINSS	SS 1.4408	16 bar	DN19	19mm	
E100DINSS	SS 1.4408	16 bar	DN25	25mm	
E125DINSS	SS 1.4408	16 bar	DN32	32mm	
E150DINSS	SS 1.4408	16 bar	DN40	38mm	
E200DINSS	SS 1.4408	16 bar	DN50	50mm	
E250DINSS	SS 1.4408	16 bar	DN65	63mm	
E300DINSS	SS 1.4408	16 bar	DN80	75mm	
E400DINSS	SS 1.4408	16 bar	DN100	100mm	

Vaterteil Typ E - EN14420-7 mit gerilltem Schlauchstutzen und Sicherungsbund

Male adapter type E - EN 14420-7 with serrated shank and collar

Adaptateur type E - Douille lisse et collerette

Camlock tipo E - DIN: acople macho - espiga lisa y cuello de seguridad

Mężczyzna Typ E zgodnie EN14420-7 - Wtyk z gładką końcówką do węża pod obejmę skorupową

Camlock tipo E - DIN: versione maschio portagomma



Part-No.	Material	WP	Dimension	Shank	Price
E075DINSS-R	SS 1.4408	16 bar	DN19	19mm	
E100DINSS-R	SS 1.4408	16 bar	DN25	25mm	
E125DINSS-R	SS 1.4408	16 bar	DN32	32mm	
E150DINSS-R	SS 1.4408	16 bar	DN40	38mm	
E200DINSS-R	SS 1.4408	16 bar	DN50	50mm	
E250DINSS-R	SS 1.4408	16 bar	DN65	63mm	
E300DINSS-R	SS 1.4408	16 bar	DN80	75mm	
E400DINSS-R	SS 1.4408	16 bar	DN100	100mm	



Vaterteil Typ E - EN14420-7 mit gerilltem Schlauchstutzen und Sicherungsbund
 PFA ausgekleidet

Male adapter type E - EN 14420-7 with serrated shank and collar PFA coated

Adaptateur type E - Douille lisse et colerette - EN 14420-7 Revêtu de PFA

Camlock tipo E - DIN: acople macho - espiga dentada y cuello de seguridad - Recubierto de PFA -

Męczyzna Typ E zgodnie EN14420-7 - Wtyk z gładką końcówką do węża pod obejmę skorupową Z powłoką PFA

Camlock tipo E - DIN: versione maschio portagomma a resca - Rivestimento in PFA

NEW



Ω
 CONDUCTIVE

Part-No.	Material	WP	Dimension	Shank	Price
E100DINSSPFA-W	SS 1.4408 PFA white coated	25 bar	DN25	25mm	
E125DINSSPFA-W	SS 1.4408 PFA white coated	25 bar	DN32	32mm	
E150DINSSPFA-W	SS 1.4408 PFA white coated	25 bar	DN40	38mm	
E200DINSSPFA-W	SS 1.4408 PFA white coated	25 bar	DN50	50mm	
E250DINSSPFA-W	SS 1.4408 PFA white coated	25 bar	DN65	63mm	
E300DINSSPFA-W	SS 1.4408 PFA white coated	25 bar	DN80	75mm	
E100DINSSPFA-B	SS 1.4408 PFA black coated	25 bar	DN25	25mm	
E125DINSSPFA-B	SS 1.4408 PFA black coated	25 bar	DN32	32mm	
E150DINSSPFA-B	SS 1.4408 PFA black coated	25 bar	DN40	38mm	
E200DINSSPFA-B	SS 1.4408 PFA black coated	25 bar	DN50	50mm	
E250DINSSPFA-B	SS 1.4408 PFA black coated	25 bar	DN65	63mm	
E300DINSSPFA-B	SS 1.4408 PFA black coated	25 bar	DN80	75mm	



Übergangsstück Kamlok Vatterteil auf IBC-Kupplung Innengewinde ohne Dichtung

Adapter camlock male type to IBC couplings female thread - without gasket

Adaptateur Kamlock mâle sur raccord IBC taraudé femelle - sans joint

Camlock tipo A con rosca tipo IBC - sin junta

Złącze IBC do paletopojemników z gwintem wewnętrznym/Wtyk CAMLOCK typ A- bez Uszczelka

Adattatore Camlock tipo A con filettatura tipo IBC- senza guarnizione



Part-No.	Material	WP	Adapter	IBC	Price
IBCF60A100-SS	SS 1.4408	xx bar	DN25	S60x6	
IBCF60A125-SS	SS 1.4408	x bar	DN32	S60x6	
IBCF60A200-SS	SS 1.4408	x bar	DN50	S60x6	

90° Bogen AG/AG flachdichtend

90° elbow male BSPP thread - flat sealing

90° Coude mâle/mâle à joint plat

Codo 90° RM-RM BSPP

90° Lolanoz gwintami zewnętrznymi cylindrycznymi

Curva 90° maschio - maschio BSPP



Part-No.	Material	WP	Thread	Thread	Price
MMS2020FL-90	SS 316	16 bar	2"	2"	
MMS3030FL-90	SS 316	16 bar	3"	3"	
MMS4040FL-90	SS 316	16 bar	4"	4"	





Vaterteil Typ A - MIL A-A-59326A mit BSPP Innengewinde

Male adapter type A - MIL A-A-59326A with female BSPP thread
 Adaptateur type A taraudé femelle BSPP - MIL A-A-59326A
 Camlock tipo A: acople macho - rosca hembra BSPP
 Męczyzna Typ A - MIL A-A-59326A - Wtyk z gwintem wewnętrznym BSPP
 Camlock tipo A: versione maschio filettato femmina BSPP

Part-No.	Material	WP	Dimension	Thread	Price
A050BR	Brass	17 bar	DN15	1/2"	
A075BR	Brass	17 bar	DN20	3/4"	
A100BR	Brass	17 bar	DN25	1"	
A125BR	Brass	17 bar	DN32	1 1/4"	
A150BR	Brass	17 bar	DN40	1 1/2"	
A200BR	Brass	17 bar	DN50	2"	
A250BR	Brass	10 bar	DN65	2 1/2"	
A300BR	Brass	10 bar	DN80	3"	
A400BR	Brass	10 bar	DN100	4"	
A500BR	Brass	5 bar	DN125	5"	
A600BR	Brass	5 bar	DN150	6"	



Mutterteil Typ B - MIL A-A-59326A mit BSPT Außengewinde mit NBR Dichtung

Female coupler type B - MIL A-A-59326A with male BSPT thread - NBR gasket

Coupleur type B fileté mâle BSPT - MIL A-A-59326A - Joint NBR

Camlock tipo B: acople hembra - rosca macho BSPT - Junta NBR

Kobieta Typ B - MIL A-A-59326A - Gniazdo z gwintem zewnętrznym BSPT - NBR Uszczelka

Camlock tipo B: versione femmina filettata maschio - Guarnizione NBR



Part-No.	Material	WP	Dimension	Thread	Price
B050BR2	Brass	17 bar	DN15	1/2"	
B075BR	Brass	17 bar	DN20	3/4"	
B100BR	Brass	17 bar	DN25	1"	
B125BR	Brass	17 bar	DN32	1 1/4"	
B150BR	Brass	17 bar	DN40	1 1/2"	
B200BR	Brass	17 bar	DN50	2"	
B250BR	Brass	10 bar	DN65	2 1/2"	
B300BR	Brass	10 bar	DN80	3"	
B400BR	Brass	10 bar	DN100	4"	
B500BR	Brass	5 bar	DN125	5"	
B600BR	Brass	5 bar	DN150	6"	





Mutterteil Typ C - MIL A-A-59326A mit Stutzen für Schelleneinband mit NBR Dichtung

Female coupler type C - MIL A-A-59326A with grooved hose-shank - NBR gasket

Coupleur type C douille annelée sans collerette - MIL A-A-59326A - Joint NBR

Camlock tipo C: acople hembra - espiga para manguera - Junta NBR

Kobieta Typ C - MIL A-A-59326A - Gniazdo z karbowaną końcówką do węża do mocowania opaskami - NBR Uszczelka

Camlock tipo C: versione femmina portagomma - Guarnizione NBR

Part-No.	Material	WP	Dimension	Shank	Price
C050BR2	Brass	17 bar	DN15	13mm	
C075BR	Brass	17 bar	DN20	21mm	
C100BR	Brass	17 bar	DN25	27mm	
C125BR	Brass	17 bar	DN32	34mm	
C150BR	Brass	17 bar	DN40	40mm	
C200BR	Brass	17 bar	DN50	51mm	
C250BR	Brass	10 bar	DN65	64mm	
C300BR	Brass	10 bar	DN80	76mm	
C400BR	Brass	10 bar	DN100	103mm	
C500BR	Brass	5 bar	DN125	128mm	
C600BR	Brass	5 bar	DN150	152mm	



Mutterteil Typ D - MIL A-A-59326A mit BSPP Innengewinde mit NBR Dichtung

Female coupler type D - MIL A-A-59326A with female BSPP thread - NBR gasket

Coupleur type D taraudé femelle BSPP - MIL A-A-59326A - Joint NBR

Camlock tipo D: acople hembra - rosca hembra BSPP - Junta NBR

Kobieta Typ D - MIL A-A-59326A - Gniazdo z gwintem wewnętrznym BSPP - NBR Uszczelka

Camlock tipo D: versione femmina filettato femmina BSPP - Guarnizione NBR



Part-No.	Material	WP	Dimension	Thread	Price
D050BR2	SS 1.4408	17 bar	DN15	1/2"	
D075BR	SS 1.4408	17 bar	DN20	3/4"	
D100BR	SS 1.4408	17 bar	DN25	1"	
D125BR	SS 1.4408	17 bar	DN32	1 1/4"	
D150BR	SS 1.4408	17 bar	DN40	1 1/2"	
D200BR	SS 1.4408	17 bar	DN50	2"	
D250BR	SS 1.4408	10 bar	DN65	2 1/2"	
D300BR	SS 1.4408	10 bar	DN80	3"	
D400BR	SS 1.4408	10 bar	DN100	4"	
D500BR	SS 1.4408	5 bar	DN125	5"	
D600BR	SS 1.4408	5 bar	DN150	6"	





Vaterteil Typ E - MIL A-A-59326A mit Stutzen für Schelleneinband

Male adapter type E - MIL A-A-59326A with grooved hose-shank
 Adaptateur type E douille annelée sans collerette - MIL A-A-59326A
 Camlock tipo E: acople macho - espiga para manguera
 Męczyzna Typ E - MIL A-A-59326A - Wtyk z karbowaną końcówką do węża do mocowania opaskami
 Camlock tipo E: versione maschio portagomma

Part-No.	Material	WP	Dimension	Shank	Price
E050BR	Brass	17 bar	DN15	13mm	
E075BR	Brass	17 bar	DN20	21mm	
E100BR	Brass	17 bar	DN25	27mm	
E125BR	Brass	17 bar	DN32	34mm	
E150BR	Brass	17 bar	DN40	40mm	
E200BR	Brass	17 bar	DN50	51mm	
E250BR	Brass	10 bar	DN65	64mm	
E300BR	Brass	10 bar	DN80	76mm	
E400BR	Brass	10 bar	DN100	103mm	
E500BR	Brass	5 bar	DN125	128mm	



Vaterteil Typ F - MIL A-A-59326A mit BSPT Außengewinde

Male adapter type F - MIL A-A-59326A with male BSPT thread

Adaptateur type A taraudé femelle - EN14420-7 - Joint de filetage PU

Camlock tipo F: acople macho - rosca macho BSPT

Męczyzna Typ F - MIL A-A-59326A - Wtyk z gwintem zewnętrznym BSPT

Camlock tipo F: versione maschio filettato maschio BSPT



Part-No.	Material	WP	Dimension	Thread	Price
F050BR	Brass	17 bar	DN15	1/2"	
F075BR	Brass	17 bar	DN20	3/4"	
F100BR	Brass	17 bar	DN25	1"	
F125BR	Brass	17 bar	DN32	1 1/4"	
F150BR	Brass	17 bar	DN40	1 1/2"	
F200BR	Brass	17 bar	DN50	2"	
F250BR	Brass	10 bar	DN65	2 1/2"	
F300BR	Brass	10 bar	DN80	3"	
F400BR	Brass	10 bar	DN100	4"	
F500BR	Brass	5 bar	DN125	5"	
F600BR	Brass	5 bar	DN150	6"	





Kappe Typ DC - MIL A-A-59326A

mit NBR Dichtung

- Dust cap type DC - MIL A-A-59326A - NBR gasket
- Bouchon coupleur type DC - MIL A-A-59326A - Joint NBR
- Camlock tipo DC: tapón hembra - Junta NBR
- Zaślepka wtyku Typ DC - MIL A-A-59326A - NBR Uszczelka
- Camlock tipo DC: tappo femmina - Guarnizione NBR

Part-No.	Material	WP	Dimension	Price
DC050BR2	Brass	17 bar	DN15	
DC075BR	Brass	17 bar	DN20	
DC100BR	Brass	17 bar	DN25	
DC125BR	Brass	17 bar	DN32	
DC150BR	Brass	17 bar	DN40	
DC200BR	Brass	17 bar	DN50	
DC250BR	Brass	10 bar	DN65	
DC300BR	Brass	10 bar	DN80	
DC400BR	Brass	10 bar	DN100	
DC500BR	Brass	5 bar	DN125	
DC600BR	Brass	5 bar	DN150	



Stopfen Typ DP - MIL A-A-59326A

Dust plug type DP - MIL A-A-59326A

Bouchon adaptateur type DP - MIL A-A-59326A

Camlock tipo DP: tapón macho

Zaślepka gniazda Typ DP - MIL A-A-59326A

Camlock tipo DP: tappo maschio



Part-No.	Material	WP	Dimension	Price
DP050BR	Brass	17 bar	DN15	
DP075BR	Brass	17 bar	DN20	
DP100BR	Brass	17 bar	DN25	
DP125BR	Brass	17 bar	DN32	
DP150BR	Brass	17 bar	DN40	
DP200BR	Brass	17 bar	DN50	
DP250BR	Brass	10 bar	DN65	
DP300BR	Brass	10 bar	DN80	
DP400BR	Brass	10 bar	DN100	
DP500BR	Brass	5 bar	DN125	
DP600BR	Brass	5 bar	DN150	



Vaterteil Typ A - EN14420-7 mit BSPP Innengewinde - flachdichtend mit PU Gewindedichtung



Male adapter type A - EN14420-7 with female BSPP thread - flat sealed - PU thread gasket
 Adaptateur type A taraudé femelle - EN14420-7 - Joint de filetage PU
 Camlock tipo A - DIN: acople macho - rosca hembra BSPP - Junta rosca PU
 Mężczyzna Typ A zgodnie EN14420-7 - Wtyk z gwintem wewnętrznym BSPP uszczelnienie płaskie - Uszczelka gwintowana
 Camlock tipo A - DIN: versione maschio filettato femmina BSPP - Guarnizione filettato PU

Part-No.	Material	WP	Dimension	Thread	Price
A075DINBR-J	Brass	16 bar	DN19	3/4"	
A100DINBR-J	Brass	16 bar	DN25	1"	
A125DINBR-J	Brass	16 bar	DN32	1 1/4"	
A150DINBR-J	Brass	16 bar	DN40	1 1/2"	
A200DINBR-J	Brass	16 bar	DN50	2"	

Mutterteil Typ C - EN14420-7 mit glattem Schlauchstutzen und Sicherungsbund mit NBR Dichtung



Female coupler type C - EN 14420-7 - with smooth shank and collar - NBR gasket
 Coupleur type C - Douille lisse et colerette - EN 14420-7- Joint NBR
 Camlock tipo C - DIN: acople hembra - espiga lisa y cuello de seguridad - Junta NBR
 Kobieta Typ C zgodnie EN14420-7 - Gniazdo z gładką końcówką do węża pod obejmę skorupową - NBR Uszczelka
 Camlock tipo C - DIN: versione femmina portagomma liscio e collare di sicurezza - Guarnizione NBR

Part-No.	Material	WP	Dimension	Shank	Price
C075DINBR-J	Brass	16 bar	DN19	19mm	
C100DINBR-J	Brass	16 bar	DN25	25mm	
C125DINBR-J	Brass	16 bar	DN32	32mm	
C150DINBR-J	Brass	16 bar	DN40	38mm	
C200DINBR-J	Brass	16 bar	DN50	50mm	



Mutterteil Typ D - EN14420-7 mit BSPP Innengewinde flachdichtend

NBR Dichtung und PU Gewindedichtung

Female coupler type D - EN14420-7 with female BSPP thread - NBR gasket + PU thread gasket

Coupleur type D taraudé femelle BSPP - EN14420-7 Joint NBR + Joint de filetage PU

Camlock tipo D - DIN: acople hembra - rosca hembra BSPP - Junta NBR + Junta rosca PU

Kobieta Typ D - EN14420-7 - Gniazdo z gwintem wewnętrznym BSPP - NBR Uszczelka + Uszczelka gwintowana

Camlock tipo D - DIN: versione femmina filettato femmina BSPP - Guarnizione PU



SCHWELLKUPPLUNGEN

Part-No.	Material	WP	Dimension	Thread	Price
D075DINBR-J	Brass	16 bar	DN19	3/4"	
D100DINBR-J	Brass	16 bar	DN25	1"	
D125DINBR-J	Brass	16 bar	DN32	1 1/4"	
D150DINBR-J	Brass	16 bar	DN40	1 1/2"	
D200DINBR-J	Brass	16 bar	DN50	2"	

Vaterteil Typ E - EN14420-7 mit glattem Schlauchstutzen und Sicherungsbund

Male adapter type E - EN 14420-7 with smooth shank and collar

Adaptateur type E - Douille lisse et collerette - EN 14420-7

Camlock tipo E - DIN: acople macho - espiga lisa y cuello de seguridad

Męczyzna Typ E zgodnie EN14420-7 - Wtyk z gładką końcówką do węża pod obejmę skorupową

Camlock tipo E - DIN: versione maschio portagomma liscio e collare di sicurezza



Part-No.	Material	WP	Dimension	Shank	Price
E075DINBR-J	Brass	16 bar	DN19	19mm	
E100DINBR-J	Brass	16 bar	DN25	25mm	
E125DINBR-J	Brass	16 bar	DN32	32mm	
E150DINBR-J	Brass	16 bar	DN40	38mm	
E200DINBR-J	Brass	16 bar	DN50	50mm	





Vaterteil Typ A - MIL A-A-59326A mit BSPP Innengewinde

Male adapter type A - MIL A-A-59326A with female BSPP thread
 Adaptateur type A taraudé femelle BSPP - MIL A-A-59326A
 Camlock tipo A: acople macho - rosca hembra BSPP
 Mężczyzna Typ A - MIL A-A-59326A - Wtyk z gwintem wewnętrznym BSPP
 Camlock tipo A: versione maschio filettato femmina BSPP

Part-No.	Material	WP	Dimension	Thread	Price
A050AL	Aluminum	10 bar	DN15	1/2"	
A075AL	Aluminum	10 bar	DN20	3/4"	
A100AL	Aluminum	10 bar	DN25	1"	
A125AL	Aluminum	10 bar	DN32	1 1/4"	
A150AL	Aluminum	10 bar	DN40	1 1/2"	
A200AL	Aluminum	10 bar	DN50	2"	
A250AL	Aluminum	10 bar	DN65	2 1/2"	
A300AL	Aluminum	10 bar	DN80	3"	
A400AL	Aluminum	7 bar	DN100	4"	
A500AL	Aluminum	5 bar	DN125	5"	
A600AL	Aluminum	5 bar	DN150	6"	
A800AL	Aluminum	4 bar	DN200	8"	



Vaterteil Typ A - mit BSPP Innengewinde

flachdichtend mit NBR Gewindedichtung

Male adapter type A - with female BSPP thread - flat sealing with NBR thread gasket
 Adaptateur type A taraudé femelle BSPP - joint plat avec joint de filetage NBR
 Camlock tipo A: acople macho - rosca hembra BSPP - Sellado plano con junta de rosca NBR
 Mężczyzna Typ A - Wtyk z gwintem wewnętrznym BSPP - uszczelnienie gwintu NBR
 Camlock tipo A: versione maschio filettato femmina BSPP - guarnizione piatta con guarnizione del filo NBR

Part-No.	Material	WP	Dimension	Thread	Price
A100AL-G	Aluminum	10 bar	DN25	1"	
A125AL-G	Aluminum	10 bar	DN32	1 1/4"	
A150AL-G	Aluminum	10 bar	DN40	1 1/2"	
A200AL-G	Aluminum	10 bar	DN50	2"	
A300AL-G	Aluminum	10 bar	DN80	3"	
A400AL-G	Aluminum	7 bar	DN100	4"	



Mutterteil Typ B - MIL A-A-59326A mit BSPT Außengewinde mit NBR Dichtung

Female coupler type B - MIL A-A-59326A with male BSPT thread - NBR gasket

Coupleur type B fileté mâle BSPT - MIL A-A-59326A - Joint NBR

Camlock tipo B: acople hembra - rosca macho BSPT Junta NBR

Kobieta Typ B - MIL A-A-59326A - Gniazdo z gwintem zewnętrznym BSPT - NBR Uszczelka

Camlock tipo B: versione femmina filettata maschio BSPT - Guarnizione NBR



Part-No.	Material	WP	Dimension	Thread	Price
B050AL	Aluminum	10 bar	DN15	1/2"	
B075AL	Aluminum	10 bar	DN20	3/4"	
B100AL	Aluminum	10 bar	DN25	1"	
B125AL	Aluminum	10 bar	DN32	1 1/4"	
B150AL	Aluminum	10 bar	DN40	1 1/2"	
B200AL	Aluminum	10 bar	DN50	2"	
B250AL	Aluminum	10 bar	DN65	2 1/2"	
B300AL	Aluminum	10 bar	DN80	3"	
B400AL	Aluminum	7 bar	DN100	4"	
B500AL	Aluminum	5 bar	DN125	5"	
B600AL	Aluminum	5 bar	DN150	6"	
B800AL	Aluminum	4 bar	DN200	8"	

Mutterteil Typ B - MIL A-A-59326A mit BSPT Außengewinde

Vakuum Einsatz - mit NBR Dichtung

Female coupler type B - MIL A-A-59326A with male BSPT thread - using vacuum - NBR gasket

Coupleur type B fileté mâle BSPT - MIL A-A-59326A - utilisation sous vide - Joint NBR

Camlock tipo B: acople hembra - rosca macho BSPT - para vacío - Junta NBR

Kobieta Typ B - MIL A-A-59326A - Gniazdo z gwintem zewnętrznym BSPT - dla próżni - NBR Uszczelka

Camlock tipo B: versione femmina filettata maschio BSPT - per il vuoto - Guarnizione NBR



NEW

Part-No.	Material	WP	Dimension	Thread	Price
B150AL-V	Aluminum	17 bar	DN40	1 1/2"	
B200AL-V	Aluminum	17 bar	DN50	2"	
B250AL-V	Aluminum	10 bar	DN65	2 1/2"	
B300AL-V	Aluminum	8,5 bar	DN80	3"	
B400AL-V	Aluminum	6,5 bar	DN100	4"	





Mutterteil Typ B - MIL A-A-59326A mit BSPT Außengewinde - System Self-Lock mit NBR Dichtung

Female coupler type B - MIL A-A-59326A with male BSPT thread - System Self-Lock - NBR gasket
 Coupleur type B fileté mâle BSPT - MIL A-A-59326A - Système Self-Lock - Joint NBR
 Camlock tipo B - Security: acople hembra - rosca macho BSPT - Anillas de seguridad- Junta NBR
 Kobieta Typ B - MIL A-A-59326A - Gniazdo z gwintem zewnętrznym BSPT - System samoblokujący - NBR Uszczelka
 Camlock femmina tipo B - MIL A-A-59326A con filettatura maschio BSPT - Guarnizione NBR

Part-No.	Material	WP	Dimension	Thread	Price
B200AL-SL	Aluminum	17 bar	DN50	2"	
B300AL-SL	Aluminum	8,5 bar	DN80	3"	
B400AL-SL	Aluminum	6,5 bar	DN100	4"	

Mutterteil Typ C - MIL A-A-59326A mit Stutzen für Schelleneinband mit NBR Dichtung



Female coupler type C - MIL A-A-59326A with grooved hose-shank - NBR gasket
 Coupleur type C douille annelée sans collerette - MIL A-A-59326A - Joint NBR
 Camlock tipo C: acople hembra - espiga para manguera - Junta NBR
 Kobieta Typ C - MIL A-A-59326A - Gniazdo z karbowaną końcówką do węży do mocowania opaskami - NBR Uszczelka
 Camlock tipo C: versione femmina portagomma - Guarnizione NBR

Part-No.	Material	WP	Dimension	Shank	Price
C050AL	Aluminum	10 bar	DN15	13mm	
C075AL	Aluminum	10 bar	DN20	21mm	
C100AL	Aluminum	10 bar	DN25	27mm	
C125AL	Aluminum	10 bar	DN32	34mm	
C150AL	Aluminum	10 bar	DN40	40mm	
C200AL	Aluminum	10 bar	DN50	51mm	
C250AL	Aluminum	10 bar	DN65	64mm	
C300AL	Aluminum	10 bar	DN80	76mm	
C400AL	Aluminum	7 bar	DN100	103mm	
C500AL	Aluminum	5 bar	DN125	128mm	
C600AL	Aluminum	5 bar	DN150	152mm	
C800AL	Aluminum	4 bar	DN200	200mm	



Mutterteil Typ C - MIL A-A-59326A mit Stutzen für Schelleneinband**Vakuu Einsatz** - mit NBR Dichtung

Female coupler type C - MIL A-A-59326A with grooved hose-shank - using vacuum - NBR gasket

Coupleur type C douille annelée sans colerette - MIL A-A-59326A - utilisation sous vide - Joint NBR

Camlock tipo C: acople hembra - espiga para manguera - para vacío - Junta NBR

Kobieta Typ C - MIL - Gniazdo z karbowaną końcówką do węża do mocowania opaskami - dla próżni NBR Uszczelka

Camlock tipo C: versione femmina portagomma - per il vuoto - Guarnizione NBR



Part-No.	Material	WP	Dimension	Shank	Price
C150AL-V	Aluminum	17 bar	DN40	40mm	
C200AL-V	Aluminum	17 bar	DN50	51mm	
C250AL-V	Aluminum	10 bar	DN65	64mm	
C300AL-V	Aluminum	8,5 bar	DN80	76mm	
C400AL-V	Aluminum	6,5 bar	DN100	103mm	

Mutterteil Typ C - MIL A-A-59326A mit drehbarem Stutzen für Schelleneinband

mit NBR Dichtung

Female coupler type C - MIL A-A-59326A with swivel grooved hose-shank - NBR gasket

Coupleur type C rotatif douille annelée sans colerette - MIL A-A-59326A - Joint NBR

Camlock Giratorio tipo C: acople hembra - espiga para manguera - Junta NBR

Kobieta Typ C - MIL A - Gniazdo z obrotową karbowaną końcówką do węża do mocowania opaskami - NBR Uszczelka

Camlock Girevole tipo C: versione femmina portagomma - Guarnizione NBR



Part-No.	Material	WP	Dimension	Shank	Price
C150AL-SW	Aluminum	10 bar	DN40	38,2mm	
C200AL-SW	Aluminum	10 bar	DN50	51mm	
C250AL-SW	Aluminum	10 bar	DN65	63,3mm	
C300AL-SW	Aluminum	10 bar	DN80	76,6mm	
C400AL-SW	Aluminum	7 bar	DN100	101,5mm	
C600AL-SW	Aluminum	5 bar	DN150	151,8mm	





Mutterteil Typ C - MIL A-A-59326A - Stutzen für Schelleneinband

Sicherheitsverschluss System Self-Lock mit NBR Dichtung

Female coupler type C - MIL A-A-59326A with grooved hose-shank - System Self-Lock - NBR gasket

Coupleur type C douille annelée sans collerette - MIL A-A-59326A - Système Self-Lock - Joint NBR

Camlock tipo C: acople hembra - espiga para manguera - Anillas de seguridad - Junta NBR

Kobieta Typ C - niazdo z karbowaną końcówką do węży do mocowania opaskami - System samoblokujący - NBR Uszczelka

Camlock femmina tipo C - MIL A-A-59326A con portagomma - Anello di sicurezza autobloccante - Guarnizione NBR

Part-No.	Material	WP	Dimension	Shank	Price
C200AL-SL	Aluminum	10 bar	DN50	51mm	
C300AL-SL	Aluminum	10 bar	DN80	76mm	
C400AL-SL	Aluminum	7 bar	DN100	103mm	



Mutterteil Typ D - MIL A-A-59326A mit BSPP Innengewinde

mit NBR Dichtung

Female coupler type D - MIL A-A-59326A with female BSPP thread - NBR gasket

Coupleur type D taraudé femelle BSPP - MIL A-A-59326A - Joint NBR

Camlock tipo D: acople hembra - rosca hembra BSPP - Junta NBR

Kobieta Typ D - MIL A-A-59326A - Gniazdo z gwintem wewnętrznym BSPP - NBR Uszczelka

Camlock tipo D: versione femmina filettato femmina BSPP - Guarnizione NBR

Part-No.	Material	WP	Dimension	Thread	Price
D050AL	Aluminum	10 bar	DN15	1/2"	
D075AL	Aluminum	10 bar	DN20	3/4"	
D100AL	Aluminum	10 bar	DN25	1"	
D125AL	Aluminum	10 bar	DN32	1 1/4"	
D150AL	Aluminum	10 bar	DN40	1 1/2"	
D200AL	Aluminum	10 bar	DN50	2"	
D250AL	Aluminum	10 bar	DN65	2 1/2"	
D300AL	Aluminum	10 bar	DN80	3"	
D400AL	Aluminum	7 bar	DN100	4"	
D500AL	Aluminum	5 bar	DN125	5"	
D600AL	Aluminum	5 bar	DN150	6"	
D800AL	Aluminum	4 bar	DN200	8"	



Mutterteil Typ D - MIL A-A-59326A mit BSPP Innengewinde - NBR Dichtung

flachdichtend mit NBR Gewindedichtung

Female coupler type D - MIL A-A-59326A with female BSPP thread - NBR gasket - flat sealing with NBR thread gasket

Coupleur type D taraudé femelle BSPP - MIL A-A-59326A Joint NBR - joint plat avec joint de filetage NBR

Camlock tipo D: acople hembra - rosca hembra BSPP - Junta NBR - Sellado plano con junta de rosca NBR

Kobieta Typ D - MIL A-A-59326A - Gniazdo z gwintem wewnętrznym BSPP - NBR Uszczelka - uszczelnienie gwintu NBR

Camlock tipo D: filettato femmina BSPP - Guarnizione NBR - guarnizione piatta con guarnizione del filo NBR



Part-No.	Material	WP	Dimension	Thread	Price
D100AL-G	Aluminum	10 bar	DN25	1"	
D125AL-G	Aluminum	10 bar	DN32	1 1/4"	
D150AL-G	Aluminum	10 bar	DN40	1 1/2"	
D200AL-G	Aluminum	10 bar	DN50	2"	
D300AL-G	Aluminum	10 bar	DN80	3"	
D400AL-G	Aluminum	7 bar	DN100	4"	

Mutterteil Typ D - MIL A-A-59326A mit BSPP Innengewinde

Vakuum Einsatz - mit NBR Dichtung

Female coupler type D - MIL A-A-59326A with female BSPP thread - using vacuum- NBR gasket

Coupleur type D taraudé femelle BSPP - MIL A-A-59326A - utilisation sous vide - Joint NBR

Camlock tipo D: acople hembra - rosca hembra BSPP - para vacío - Junta NBR

Kobieta Typ D - MIL A-A-59326A - Gniazdo z gwintem wewnętrznym BSPP - dla próżni - NBR Uszczelka

Camlock tipo D: versione femmina filettato femmina BSPP - per il vuoto - Guarnizione NBR

**NEW**

Part-No.	Material	WP	Dimension	Thread	Price
D150AL-V	Aluminum	17 bar	DN40	1 1/2"	
D200AL-V	Aluminum	10 bar	DN50	2"	
D250AL-V	Aluminum	10 bar	DN65	2 1/2"	
D300AL-V	Aluminum	10 bar	DN80	3"	
D400AL-V	Aluminum	7 bar	DN100	4"	





Mutterteil Typ D - MIL A-A-59326A mit BSPP Innengewinde

Sicherheitsverschluss System Self-Lock mit NBR Dichtung

Female coupler type D - MIL A-A-59326A with female BSPP thread - System Self-Lock - NBR gasket

Coupleur type D taraudé femelle BSPP - MIL A-A-59326A - Système Self-Lock - Joint NBR

Camlock tipo D - Security: acople hembra - rosca hembra BSPP - Anillas de seguridad - Junta NBR

Kobieta Typ D - MIL A-A-59326A - Gniazdo z gwintem wewnętrznym BSPP - System samoblokujący - NBR Uszczelka

Camlock tipo D - MIL A-A-59326 A con filettatura femmina BSPP - Anelli di sicurezza autobloccante - Guarnizione NBR

Part-No.	Material	WP	Dimension	Thread	Price
D200AL-SL	Aluminum	10 bar	DN50	2"	
D300AL-SL	Aluminum	10 bar	DN80	3"	
D400AL-SL	Aluminum	7 bar	DN100	4"	

Vaterteil Typ E - MIL A-A-59326A mit Stutzen für Schelleneinband

Male adapter type E - MIL A-A-59326A with grooved hose-shank

Adaptateur type E douille annelée sans collerette - MIL A-A-59326A

Camlock tipo E: acople macho - espiga para manguera

Męczyzna Typ E - MIL A-A-59326A - Wtyk z karbowaną końcówką do węży do mocowania opaskami

Camlock tipo E: versione maschio portagomma



Part-No.	Material	WP	Dimension	Shank	Price
E050AL	Aluminum	10 bar	DN15	13mm	
E075AL	Aluminum	10 bar	DN20	21mm	
E100AL	Aluminum	10 bar	DN25	27mm	
E125AL	Aluminum	10 bar	DN32	34mm	
E150AL	Aluminum	10 bar	DN40	40mm	
E200AL	Aluminum	10 bar	DN50	51mm	
E250AL	Aluminum	10 bar	DN65	64mm	
E300AL	Aluminum	10 bar	DN80	76mm	
E400AL	Aluminum	7 bar	DN100	103mm	
E500AL	Aluminum	5 bar	DN125	128mm	
E600AL	Aluminum	5 bar	DN150	152mm	
E800AL	Aluminum	4 bar	DN200	200mm	



Vaterteil Typ F - MIL A-A-59326A mit BSPT Außengewinde

Male adapter type F - MIL A-A-59326A with male BSPT thread

Adaptateur type F fileté mâle BSPT - MIL A-A-59326A

Camlock tipo F: acople macho - rosca macho BSPT

Męczyzna Typ F - MIL A-A-59326A - Wtyk z gwintem zewnętrznym BSPT

Camlock tipo F: versione maschio filettato maschio BSPT



Part-No.	Material	WP	Dimension	Thread	Price
F050AL	Aluminum	10 bar	DN15	1/2"	
F075AL	Aluminum	10 bar	DN20	3/4"	
F100AL	Aluminum	10 bar	DN25	1"	
F125AL	Aluminum	10 bar	DN32	1 1/4"	
F150AL	Aluminum	10 bar	DN40	1 1/2"	
F200AL	Aluminum	10 bar	DN50	2"	
F250AL	Aluminum	10 bar	DN65	2 1/2"	
F300AL	Aluminum	10 bar	DN80	3"	
F400AL	Aluminum	7 bar	DN100	4"	
F500AL	Aluminum	5 bar	DN125	5"	
F600AL	Aluminum	5 bar	DN150	6"	
F800AL	Aluminum	4 bar	DN200	8"	





Kappe Typ DC - MIL A-A-59326A - NBR Dichtung

Dust cap type DC - MIL A-A-59326A - NBR gasket
 Bouchon coupleur type DC -MIL A-A-59326A - Joint NBR
 Camlock tipo DC: tapón hembra - MIL A-A-59326A - Junta NBR
 Zaślepka wtyku Typ DC - MIL A-A-59326A - NBR Uszczelka
 Camlock tipo DC: tappo femmina- MIL A-A-59326A - Guarnizione NBR

Part-No.	Material	WP	Dimension	Price
DC050AL	Aluminum	10 bar	DN15	
DC075AL	Aluminum	10 bar	DN20	
DC100AL	Aluminum	10 bar	DN25	
DC125AL	Aluminum	10 bar	DN32	
DC150AL	Aluminum	10 bar	DN40	
DC200AL	Aluminum	10 bar	DN50	
DC250AL	Aluminum	10 bar	DN65	
DC300AL	Aluminum	10 bar	DN80	
DC400AL	Aluminum	7 bar	DN100	
DC500AL	Aluminum	5 bar	DN125	
DC600AL	Aluminum	5 bar	DN150	
DC800AL	Aluminum	4 bar	DN200	



Kappe Typ DC - MIL A-A-59326A - Sicherheitsverschluss System Self-Lock mit NBR Dichtung

Dust cap type DC - MIL A-A-59326A - System Self-Lock - NBR gasket
 Bouchon coupleur type DC -MIL A-A-59326A - Système Self-Lock - Joint NBR
 Camlock tipo DC - Security: Tapón hembra - Anillas de seguridad - Junta NBR
 Zaślepka wtyku Typ DC - MIL A-A-59326A - System samoblokujący - NBR Uszczelka
 Tappo camlock tipo DC - MIL A-A- 59326A - Anelli di sicurezza autobloccante - Guarnizione NBR

Part-No.	Material	WP	Dimension	Price
DC200AL-SL	Aluminum	10 bar	DN50	
DC300AL-SL	Aluminum	10 bar	DN80	
DC400AL-SL	Aluminum	7 bar	DN100	



Kappe Typ DC - MIL A-A-59326A - 90° Hebel - abschließbar mit NBR Dichtung

Dust cap type DC - MIL A-A-59326A - 90° Lever - lockable - NBR gasket

Bouchon coupleur type DC - MIL A-A-59326A - levier 90° - Joint NBR

Tapón camlock tipo DC - MIL A-A-59326A con levas a 90° - Junta NBR

Zaślepka wtyku Typ DC - MIL A-A-59326A z 90° klamką - NBR Uszczelka

Tappo camlock tipo DC - MIL A-A-59326A con leve di sicurezza di 90° - Guarnizione NBR



Part-No.	Material	WP	Dimension	Price
DC200AL-90	Aluminum	10 bar	DN50	
DC300AL-90	Aluminum	10 bar	DN80	
DC400AL-90	Aluminum	7 bar	DN100	

Stopfen Typ DP - MIL A-A-59326A

Dust plug type DP - MIL A-A-59326A

Bouchon adaptateur type DP - MIL A-A-59326A

Camlock tipo DP: tapón macho- MIL A-A-59326A

Zaślepka gniazda Typ DP - MIL A-A-59326A

Camlock tipo DP: tappo maschio - MIL A-A-59326A



Part-No.	Material	WP	Dimension	Price
DP050AL	Aluminum	10 bar	DN15	
DP075AL	Aluminum	10 bar	DN20	
DP100AL	Aluminum	10 bar	DN25	
DP125AL	Aluminum	10 bar	DN32	
DP150AL	Aluminum	10 bar	DN40	
DP200AL	Aluminum	10 bar	DN50	
DP250AL	Aluminum	10 bar	DN65	
DP300AL	Aluminum	10 bar	DN80	
DP400AL	Aluminum	7 bar	DN100	
DP500AL	Aluminum	5 bar	DN125	
DP600AL	Aluminum	5 bar	DN150	
DP800AL	Aluminum	4 bar	DN200	



Kamlok Adapter Stücke - MIL A-A-59326A

weitere Nennweiten und Kombinationen auf Anfrage

Camlock adapter - MIL A-A-59326A - Other Sizes and Adapter available

Raccord à cames - MIL A-A-59326A - Autres largeurs nominales et combinaisons disponibles

Adaptador camlock - MIL A-A-59326A - Otras medidas y adaptadores disponibles

Camlock Adapter - MIL A-A-59326A - Inne rozmiary i adaptory dostępne

Adattatore camlock - MIL A-A- 59326A - Altre dimensioni e adattatori disponibili



Typ A-A



Typ D-A



Typ D-D

Part-No.	Material	Typ	WP	DN1	DN2	Price
AA200200AL	Aluminum	A-A	10 bar	DN50	DN50	
DA150100AL	Aluminum	D-A	10 bar	DN40	DN25	
DA150200AL	Aluminum	D-A	10 bar	DN40	DN50	
DA200150AL	Aluminum	D-A	10 bar	DN50	DN38	
DA200300AL	Aluminum	D-A	10 bar	DN50	DN80	
DA200400AL	Aluminum	D-A	7 bar	DN50	DN100	
DA300200AL	Aluminum	D-A	10 bar	DN80	DN50	
DA300250AL	Aluminum	D-A	10 bar	DN80	DN65	
DA300400AL	Aluminum	D-A	7 bar	DN80	DN100	
DA400200AL	Aluminum	D-A	10 bar	DN100	DN50	
DA400300AL	Aluminum	D-A	7 bar	DN100	DN80	
DA400600AL	Aluminum	D-A	5 bar	DN100	DN150	
DA600400AL	Aluminum	D-A	5 bar	DN150	DN100	
DA800600AL	Aluminum	D-A	4 bar	DN200	DN150	
DD200200AL	Aluminum	D-D	10 bar	DN50	DN50	

Reduzierung IG/IG flachdichtend - NBR Dichtung

Reducer female thread BSPP - female thread BSPP - NBR flat sealing

Réduction femelle/femelle à joint plat NBR

Reducción rosca hembra BSPP - rosca hembra BSPP - junta NBR

Redukcja z gwintami zewnętrznymi cylindrycznymi - NBR Uszczelka

Riduzione filettato femmina BSPP - filettato femmina BSPP - guarnizione NBR



Part-No.	Material	WP	Thread	Thread	Price
FFA6040FL	Aluminum		6"	4"	



Reduzierung IG/IG - mit kurzem Gewinde

Reduction female BSPP thread - with short thread

Réduction double femelle/femelle - avec filetage court

Reducción rosca hembra BSPP - con rosca corta

Redukcja z gwintami - z krótkim gwintem

Riduzione filettato femmina BSPP - con filo corto



Part-No.	Material	WP	Thread	Thread	Price
FFA2015	Aluminum	16 bar	2"	1 1/2"	
FFA2515	Aluminum	16 bar	2 1/2"	1 1/2"	
FFA2520	Aluminum	16 bar	2 1/2"	2"	
FFA3015	Aluminum	16 bar	3"	1 1/2"	
FFA3020	Aluminum	16 bar	3"	2"	
FFA3025	Aluminum	16 bar	3"	2 1/2"	
FFA4015	Aluminum	16 bar	4"	1 1/2"	
FFA4020	Aluminum	16 bar	4"	2"	
FFA4025	Aluminum	16 bar	4"	2 1/2"	
FFA4030	Aluminum	16 bar	4"	3"	

90° Bogen AG/AG flachdichtend

90° Elbow male BSPP thread - flat sealing

90° Coude mâle/mâle à joint plat

Codo 90° RM-RM BSPP

90° Lolanoz gwintami zewnętrznymi cylindrycznymi

Curva 90° maschio - maschio BSPP



Part-No.	Material	WP	Thread	Thread	Price
MMA2020FL-90	Aluminum	10 bar	2"	2"	
MMA3030FL-90	Aluminum	10 bar	3"	3"	
MMA4040FL-90	Aluminum	10 bar	4"	4"	





Vaterteil Typ A - MIL A-A-59326A mit BSPP Innengewinde

Male adapter type A - MIL A-A-59326A with female BSPP thread
 Adaptateur type A taraudé femelle BSPP - MIL A-A-59326A
 Camlock tipo A: acople macho - rosca hembra BSPP
 Mężczyzna Typ A - MIL A-A-59326A - Wtyk z gwintem wewnętrznym BSPP
 Camlock tipo A: versione maschio filettato femmina BSPP

Part-No.	Material	WP	Dimension	Thread	Price
A075x050PP	Polypropylene	8,5 bar	DN20	1/2"	
A075PP	Polypropylene	8,5 bar	DN20	3/4"	
A100PP	Polypropylene	8,5 bar	DN25	1"	
A125PP	Polypropylene	6,5 bar	DN32	1 1/4"	
A150x125PP	Polypropylene	6,5 bar	DN40	1 1/4"	
A150PP	Polypropylene	6,5 bar	DN40	1 1/2"	
A200PP	Polypropylene	6,5 bar	DN50	2"	
A300PP	Polypropylene	5 bar	DN80	3"	
A400PP	Polypropylene	5 bar	DN100	4"	



Mutterteil Typ B - MIL A-A-59326A mit BSPT Außengewinde mit EPDM Dichtung

Female coupler type B - MIL A-A-59326A with male BSPT thread - EPDM gasket
 Coupleur type B fileté mâle BSPT - MIL A-A-59326A - Joint EPDM
 Camlock tipo B: acople hembra - rosca macho BSPT- Junta EPDM
 Kobieta Typ B - MIL A-A-59326A - Gniazdo z gwintem zewnętrznym BSPT - EPDM Uszczelka
 Camlock tipo B: versione femmina filettata maschio BSPT - Guarnizione EPDM

Part-No.	Material	WP	Dimension	Thread	Price
B075x050PP	Polypropylene	8,5 bar	DN20	1/2"	
B075PP	Polypropylene	8,5 bar	DN20	3/4"	
B100PP	Polypropylene	8,5 bar	DN25	1"	
B125PP	Polypropylene	6,5 bar	DN32	1 1/4"	
B150x125PP	Polypropylene	6,5 bar	DN40	1 1/4"	
B150PP	Polypropylene	6,5 bar	DN40	1 1/2"	
B200PP	Polypropylene	6,5 bar	DN50	2"	
B300PP	Polypropylene	5 bar	DN80	3"	
B400PP	Polypropylene	5 bar	DN100	4"	



Mutterteil Typ C nach MIL A-A-59326A mit Stutzen für Schelleneinband mit EPDM Dichtung

Female coupler type C - MIL A-A-59326A with grooved hose-shank - EPDM gasket

Coupleur type C douille annelée sans collerette - MIL A-A-59326A - Joint EPDM

Camlock tipo C: acople hembra - espiga para manguera - Junta EPDM

Kobieta Typ C - MIL A-A-59326A - Gniazdo z karbowaną końcówką do węży do mocowania opaskami - EPDM Uszczelka

Camlock tipo C: versione femmina portagomma - Guarnizione EPDM



Part-No.	Material	WP	Dimension	Shank	Price
C075x050PP	Polypropylene	8,5 bar	DN20	13mm	
C075PP	Polypropylene	8,5 bar	DN20	21mm	
C100PP	Polypropylene	8,5 bar	DN25	27mm	
C125PP	Polypropylene	6,5 bar	DN32	34mm	
C150x125PP	Polypropylene	6,5 bar	DN40	34mm	
C150PP	Polypropylene	6,5 bar	DN40	40mm	
C200x100PP	Polypropylene	6,5 bar	DN50	27mm	
C200x150PP	Polypropylene	6,5 bar	DN50	40mm	
C200PP	Polypropylene	6,5 bar	DN50	51mm	
C300PP	Polypropylene	5 bar	DN80	76mm	
C400PP	Polypropylene	5 bar	DN100	103mm	

Mutterteil Typ C nach MIL A-A-59326A mit Stutzen für Schelleneinband (90° Bogen) - EPDM Dichtung

Female coupler type C - MIL A-A-59326A with grooved hose-shank (90° Elbow) - EPDM gasket

Coupleur type C douille annelée sans collerette - MIL A-A-59326A - Joint EPDM

Camlock hembra tipo C 90° - MIL A-A-59326A - Junta EPDM

Kobieta Typ C - MIL A-A-59326A - Gniazdo z karbowaną końcówką do węży do mocowania opaskami - EPDM Uszczelka

Camlock tipo C: versione femmina a 90 gradi - Guarnizione EPDM



Part-No.	Material	WP	Dimension	Shank	Price
C100PP-90	Polypropylene	8,5 bar	DN25	27mm	
C150PP-90	Polypropylene	6,5 bar	DN40	40mm	
C200PP-90	Polypropylene	6,5 bar	DN50	51mm	
C300PP-90	Polypropylene	5 bar	DN80	76mm	





Mutterteil Typ D nach MIL A-A-59326A mit BSPP Innengewinde mit EPDM Dichtung

Female coupler type D - MIL A-A-59326A with female BSPP thread - EPDM gasket
 Coupleur type D taraudé femelle BSPP - MIL A-A-59326A - Joint EPDM
 Camlock tipo D: acople hembra - rosca hembra BSPP- Junta EPDM
 Kobieta Typ D - MIL A-A-59326A - Gniazdo z gwintem wewnętrznym BSPP - EPDM Uszczelka
 Camlock tipo D: versione femmina filettato femmina BSPP - Guarnizione EPDM

Part-No.	Material	WP	Dimension	Thread	Price
D075x050PP	Polypropylene	8,5 bar	DN20	1/2"	
D075PP	Polypropylene	8,5 bar	DN20	3/4"	
D100PP	Polypropylene	8,5 bar	DN25	1"	
D125PP	Polypropylene	6,5 bar	DN32	1 1/4"	
D150x125PP	Polypropylene	6,5 bar	DN40	1 1/4"	
D150PP	Polypropylene	6,5 bar	DN40	1 1/2"	
D200PP	Polypropylene	6,5 bar	DN50	2"	
D300PP	Polypropylene	5 bar	DN80	3"	
D400PP	Polypropylene	5 bar	DN100	4"	

Vaterteil Typ E nach MIL A-A-59326A mit Stutzen für Schelleneinband



Male adapter type E - MIL A-A-59326A with grooved hose-shank
 Adaptateur type E douille annelée sans collerette - MIL A-A-59326A
 Camlock tipo E: acople macho - espiga para manguera
 Mężczyzna Typ E - MIL A-A-59326A - Wtyk z karbowaną końcówką do węża do mocowania opaskami
 Camlock tipo E: versione maschio portagomma

Part-No.	Material	WP	Dimension	Shank	Price
E075x050PP	Polypropylene	8,5 bar	DN20	13mm	
E075PP	Polypropylene	8,5 bar	DN20	21mm	
E100PP	Polypropylene	8,5 bar	DN25	27mm	
E125PP	Polypropylene	6,5 bar	DN32	34mm	
E150x125PP	Polypropylene	6,5 bar	DN40	34mm	
E150PP	Polypropylene	6,5 bar	DN40	40mm	
E200PP	Polypropylene	6,5 bar	DN50	51mm	
E300PP	Polypropylene	5 bar	DN80	76mm	
E400PP	Polypropylene	5 bar	DN100	103mm	



Vaterteil Typ F nach MIL A-A-59326A mit BSPT Außengewinde

Male adapter type F - MIL A-A-59326A with male BSPT thread

Adaptateur type F fileté mâle BSPT - MIL A-A-59326A

Camlock tipo F: acople macho - rosca macho BSP

Męczyzna Typ F - MIL A-A-59326A - Wtyk z gwintem zewnętrznym BSPT

Camlock tipo F: versione maschio filettato maschio BSPT



Part-No.	Material	WP	Dimension	Thread	Price
F075x050PP	Polypropylene	8,5 bar	DN20	1/2"	
F075PP	Polypropylene	8,5 bar	DN20	3/4"	
F100PP	Polypropylene	8,5 bar	DN25	1"	
F125PP	Polypropylene	6,5 bar	DN32	1 1/4"	
F150x125PP	Polypropylene	6,5 bar	DN40	1 1/4"	
F150PP	Polypropylene	6,5 bar	DN40	1 1/2"	
F200PP	Polypropylene	6,5 bar	DN50	2"	
F300PP	Polypropylene	5 bar	DN80	3"	
F400PP	Polypropylene	5 bar	DN100	4"	

Vaterteil Typ F nach MIL A-A-59326A mit BSPT Außengewinde (90° Bogen)

Male adapter type F - MIL A-A-59326A with male BSPT thread (90° Elbow)

Adaptateur type F fileté mâle BSPT - MIL A-A-59326A (90° Coude)

Camlock tipo F: acople macho - rosca macho BSPT (90° Codo)

Męczyzna Typ F - MIL A-A-59326A - Wtyk z gwintem zewnętrznym BSPT (90° Lolanoz)

Camlock tipo F: versione maschio filettato maschio BSPT (90° Curva)



Part-No.	Material	WP	Dimension	Shank	Price
F200PP-90	Polypropylene	6,5 bar	DN50	51mm	





Kappe Typ DC nach MIL A-A-59326A

mit EPDM Dichtung

Dust cap type DC - MIL A-A-59326A - EPDM gasket

Bouchon coupleur type DC -MIL A-A-59326A - Joint EPDM

Camlock tipo DC: tapón hembra - Junta EPDM

Zaślepka wtyku Typ DC - MIL A-A-59326A - EPDM Uszczelka

Camlock tipo DC: tappo femmina - Guarnizione EPDM

Part-No.	Material	WP	Dimension	Price
DC075PP	Polypropylene	8,5 bar	DN20	
DC100PP	Polypropylene	8,5 bar	DN25	
DC125PP	Polypropylene	6,5 bar	DN32	
DC150PP	Polypropylene	6,5 bar	DN40	
DC200PP	Polypropylene	6,5 bar	DN50	
DC300PP	Polypropylene	5 bar	DN80	
DC400PP	Polypropylene	5 bar	DN100	



Stopfen Typ DP nach MIL A-A-59326A

Dust plug type DP - MIL A-A-59326A

Bouchon adaptateur type DP - MIL A-A-59326A

Camlock tipo DP: Tapón macho - MIL A-A-59326A

Zaślepka gniazda Typ DP - MIL A-A-59326A

Camlock tipo DP: tappo maschio - MIL A-A-59326A

Part-No.	Material	WP	Dimension	Price
DP075PP	Polypropylene	8,5 bar	DN20	
DP100PP	Polypropylene	8,5 bar	DN25	
DP125PP	Polypropylene	6,5 bar	DN32	
DP150PP	Polypropylene	6,5 bar	DN40	
DP200PP	Polypropylene	6,5 bar	DN50	
DP300PP	Polypropylene	5 bar	DN80	
DP400PP	Polypropylene	5 bar	DN100	



Mutterteil Typ C - mit gerilltem Schlauchstutzen und Sicherungsbund mit EPDM Dichtung

Female coupler Type C - with serrated shank and collar - EPDM gasket

Coupleur type C - Douille annelée et collerette- Joint EPDM

Adaptador hembra tipo C con espiga dentada - Junta EPDM

Kobieta Typ C - Gniazdo z karbowaną końcówką do węża pod - EPDM Uszczelka

Adattatore femmina tipo C portagomma a resca - Guarnizione EPDM



SCHWELLKUPPLUNGEN

Part-No.	Material	WP	Dimension	Shank	Price
C075DINPP-R	Polypropylene	3 bar	DN20	21mm	
C100DINPP-R	Polypropylene	3 bar	DN25	27mm	
C125DINPP-R	Polypropylene	3 bar	DN32	34mm	
C150DINPP-R	Polypropylene	3 bar	DN40	40mm	
C200DINPP-R	Polypropylene	3 bar	DN50	51mm	

Vaterteil Typ E mit gerilltem Schlauchstutzen und Sicherungsbund

Male adapter type E - with serrated shank and collar

Adaptateur type E - Douille lisse et collerette

Adaptador macho tipo E con espiga dentada y cuello de seguridad

Męczyzna Typ E zgodnie - Wtyk z gładką końcówką do węża pod obejmę skorupową

Adattatore maschio tipo E portagomma a resca e collare di sicurezza



Part-No.	Material	WP	Dimension	Shank	Price
E075DINPP-R	Polypropylene	3 bar	DN20	21mm	
E100DINPP-R	Polypropylene	3 bar	DN25	27mm	
E125DINPP-R	Polypropylene	3 bar	DN32	34mm	
E150DINPP-R	Polypropylene	3 bar	DN40	40mm	
E200DINPP-R	Polypropylene	3 bar	DN50	51mm	





Kamlok Adapter Stücke - MIL A-A-59326A

weitere Nennweiten und Kombinationen auf Anfrage

Camlock adapter - MIL A-A-59326A - Other sizes and adapter available

Raccord à cames - MIL A-A-59326A - Autres largeurs nominales et combinaisons disponibles

Adaptador camlock - MIL A-A-59326A - Otras medidas y adaptadores disponibles

Camlock Adapter - MIL A-A-59326A - Inne rozmiary i adaptory dostępne

Adattatore camlock - MIL A-A- 59326A - Altre dimensioni e adattatori disponibili

Part-No.	Material	Typ	WP	DN1	DN2	Price
DA300200PP	Polypropylene	D-A	5 bar	DN80	DN50	



Übergangsstück Kamlok Vatterteil auf IBC Innengewinde

Adapter camlock male type to IBC female thread

Adaptateur à cames mâle sur raccord IBC taraudé femelle

Adaptador Camlock macho con rosca hembra en soporte IBC

Złącze IBC do paletopojemników z gwintem wewnętrznym/Wtyk CAMLOCK typ A

Adattatore camlock maschio con filettato femmina su supporto IBC

Part-No.	Material	C&G	IBC	Gasket	Price
IBCF60A100	Polypropylene	DN25	S60x6	PE	
IBCF60A150	Polypropylene	DN40	S60x6	PE	
IBCF60A200	Polypropylene	DN50	S60x6	PE	
IBCF100A200	Polypropylene	DN50	S100x8	PE	



Übergangsstück Kamlok Mutterteil auf IBC Außengewinde

Adapter camlock female type to IBC male thread

Coupleur femelle sur raccord IBC fileté mâle

Adaptador camlock hembra con rosca macho IBC

Złącze IBC do paletopojemników z gwintem zewnętrznym/Wtyk CAMLOCK typ B

Adattatore camlock femmina con filettato maschio IBC

Part-No.	Material	C&G	IBC	Gasket	Price
IBCM60B200	Polypropylene	DN50	S60x6	EPDM	



Reparatur-Set für Kamlok (Hebel, Ring, Stift)

Replacement handle includes ring and pin

Kit de réparation de Camlock (came + axe + goupille)

Set de repuesto para Camlock (Palanca, anillo y pasador)

Zestaw naprawczy do Camlock (dźwignia, pierścień, bolec)

Set di ricambio per Camlock (leva, anello e perno)

Part-No.	Material	Dim1	Dim 2	Price
CH75SS	SS 304	1/2"	3/4"	
CH100SS	SS 304	1"	1"	
CH200SS	SS 304	1 1/4"	2 1/2"	
CH300SS	SS 304	3"	5"	
CH600SS	SS 304	6"	6"	
CH75SS-M	SS 304	1/2"	3/4"	
CH100SS-M	SS 304	1"	1"	
CH200SS-M	SS 304	1 1/4"	2 1/2"	
CH300SS-M	SS 304	3"	5"	
CH200SS-90	SS 304	2"	2"	
CH300SS-90	SS 304	3"	4"	
CH75BR	Brass	1/2"	3/4"	
CH100BR	Brass	1"	1"	
CH200BR	Brass	1 1/4"	2 1/2"	
CH300BR	Brass	3"	5"	
CH600BR	Brass	6"		
CH200SS-SL	SS 304	1 1/4"	2 1/2"	
CH300SS-SL	SS 304	3"	5"	
CH200BR-SL	Brass	1 1/4"	2 1/2"	
CH300BR-SL	Brass	3"	5"	



Zubehör



- Accessories
- Accessoires
- Accesorios
- Akcesoria
- Accessori

Part-No.	Material	Price
36310 ⁽¹⁾	Brass	
36310-SS ⁽²⁾	Stainless Steel	
SS12CH ⁽³⁾	Stainless Steel	
CGP ⁽⁴⁾	Steel	
CGP-SS ⁽⁵⁾	Stainless Steel	

Schauglas mit beidseitigem BSPP Außengewinde, Material PC

- Sight glass with both sides BSPP male thread, polycarbonate
- Tube transparent Filetage mâle BSPP des deux côtés, polycarbonate
- Mirilla con rosca macho BSPP en ambos lados, material PC
- Tubo transparente rosca macho BSPP en ambos lados, policarbonato
- Tubo trasparente con filetto maschio BSPP su entrambi i lati, policarbonato

Part-No.	Material	WP	Thread	Thread	Length	Price
SGBSPM200	Polycarbonate	10 bar	2"	2"	200mm	
SGBSPM300	Polycarbonate	10 bar	3"	3"	200mm	
SGBSPM400	Polycarbonate	10 bar	4"	4"	200mm	



Vorhängeschloss für abschließbare Kupplungen

Padlock
 Cadenas
 Candado
 Kłódka z
 Lucchetto



Part-No.	Material	Description	Price
LOCKSS	SS304	Padlock in SS304 with keys	
LOCKSS2	SS304	Padlock in SS304 with keys (long bolt)	
LOCKBR	Brass	Padlock in brass with keys	





WARUM MCC

- Entsprechend der PED (Anhang I „wesentliche Sicherheitsanforderungen“) Prüfung und Nachweis der Druckstufen.
- Diese Kupplungen sind in der Druckstufe deutlich besser als die Norm DIN EN 14420-7.
- Die Dichtungen sind auf die hohen Drücke ausgelegt
- Ringförmige Hebelsicherung gut mit dicken Handschuhen bedienbar
- Hebel können nicht brechen, so dass die Verletzungsgefahr minimiert ist



- Typ D (MIL A-A-59326A, EN14420-7) - verschiedene Ausführungen in SS 316:
- 2/3/4 Hebel Ausführung möglich 16 - 100 bar Betriebsdruck
 - mit oder ohne Self-Lock (Sicherheitsverschluss)
 - mit Gewindedichtung (flachdichtend) oder ohne Gewindedichtung



- Typ C Muttererteil (MIL A-A-59326A, EN14420-7) - verschiedene Ausführungen in SS 316:
- für Gummi- oder Flachschauch 16 - 60 bar Betriebsdruck
 - zur Verpressung mit Presshülsen, Klemmschaleneinband oder Drahteinband
 - mit oder ohne Self-Lock (Sicherheitsverschluss)



- Typ E Vatterteil (MIL A-A-59326A, EN14420-7) - verschiedene Ausführungen in SS 316:
- für Gummi- oder Flachschauch 16 - 60 bar Betriebsdruck
 - zur Verpressung mit Presshülsen, Klemmschaleneinband oder Drahteinband



- Schalenverschraubung - verschiedene Ausführungen in SS 316:
- zur Verpressung mit Presshülsen oder Klemmschaleneinband 25 - 60 bar Betriebsdruck



- Presshülsen/Klemmschalen - verschiedene Farben und Werkstoffe:
- für Gummi- oder Flachschauch 25 - 60 bar Betriebsdruck



- Typ A Vatterteil (MIL A-A-59326A, EN14420-7) - verschiedene Ausführungen in SS 316:
- 16 - 25 bar Betriebsdruck
 - mit Innengewinde flachdichtend oder konisch dichtend



INFORMATION

Snow Cannon Couplings and accessories

WHY MCC

- In accordance with the PED (Annex I “Essential Safety Requirements”) testing and verification of the pressure ratings.
- The pressure rating of these couplings is significantly better than the DIN EN 14420-7 standard.
- The gaskets are designed for high pressures
- Ring-shaped lever lock can be easily operated with thick gloves
- Levers cannot break, so the risk of injury is minimized



Type D female coupler (MIL A-A-59326A, EN14420-7) - different versions in SS 316:

- 2/3/4 handles available - 16 - 100 bar working pressure
- with or without Self-Lock
- with thread gasket (flat sealing) or without gasket



Type C female coupler (MIL A-A-59326A, EN14420-7) - different versions in SS 316:

- for rubber or flat hose 16 - 60 bar working pressure
- for crimping with ferrule, safety clamps or wire binding
- with or without Self-Lock



Type E male adapter (MIL A-A-59326A, EN14420-7) - different versions in SS 316:

- for rubber or flat hose 16 - 60 bar working pressure
- for crimping with ferrule, safety clamps or wire binding



Male/Female thread - different versions in SS 316:

- for crimping with ferrule or safety clamps 25 - 60 bar working pressure



Ferrule/Safety Clamps - different colors and materials:

- for rubber or flat hose 25 - 60 bar working pressure



Type A male adapter (MIL A-A-59326A, EN14420-7) - different versions in SS 316:

- 16 - 25 bar working pressure
- with thread gasket (flat sealing) or without gasket

INFORMATIONEN

Guillemin



Die Guillemin Armatur ist die einzige symmetrische Schnellkupplung der DIN EN 14420 Normserie. Ihre Aufnahme in diese Normreihe hat gute Gründe: Die Armatur lässt sich schnell und einfach kuppeln, kann durch einen Stelling vor ungewolltem Lösen gesichert werden. Sie ist so konstruiert, dass einseitige Belastungen die Dichtung nicht beschädigen.

Im Gegensatz zur deutschen Tankwagenkupplung EN14420-6 kann die Guillemin noch mit einem Hakenschlüssel zusätzlich festgezogen werden.

Ihr große Vorteil liegt in der symmetrischen Ausführung. Sie erhöht die Flexibilität im Anschließen von Schlauchleitungen. Somit lassen sich erhebliche Kosten einsparen, da nicht mehr auf die

Kombination Vater-, Mutterteil geachtet werden muß.

MCC bietet auch ein drehbare Versionen der Kupplung an. Diese Kupplung sollte immer mit in Betracht gezogen werden, wenn Anlagen voneinander durch Kombination von Anschlußsystemen abgegrenzt werden sollten.

WARUM MCC?

- Lange Erfahrung in den Kern- Guillemin-Märkten Frankreich, Spanien und Italien
- Erfüllt auch die strenge Norm NF E29-572
- Armaturen eignen sich auch für Schlauchleitungen nach IN EN 12115
- Hohe Verfügbarkeit und breites Armaturen Sortiment (inklusive drehbaren Ausführungen)
- Breites Angebot an Zubehör (bspw. Dichtungen)
- PFA Beschichte Armaturen erhältlich (werden häufig verwendet, wenn Flexibilität und ein höherer Dauerbetriebstemperaturbereich erforderlich ist.)



TECHNISCHE INFORMATIONEN

- Normen: DIN EN 14420-8; NF E29-572
- Verschiedenste Anschlußmöglichkeiten: gerillter Schlauchstutzen für Klemmschalen, ISO 228 Gewinde, Anschweissende, Composite Schläuche
- Größe: DN 20 bis DN 150
- Betriebsdruck: -0,8 bis 6/10/16 bar bei 65°C je nach Werkstoff
- Armaturenwerkstoffe: Polypropylen Aluminium, Messing, Edelstahl
- Kupplungsdichtungen: NBR, FKM, EPDM, PTFE, Silikon, nach EU1935/2004, FDA für Lebensmittel
Gewindedichtungen: PTFE, PU,

FKM, EPDM, NBR, Silikon, nach EU1935/2004, FDA für Lebensmittel

EINSATZGEBIET

Sie ist universell einsetzbar, wird aber überwiegend für den Anschluß an Tanklastfahrzeuge genutzt.

Durch den robusten Aufbau können Feststoffe, sedimenthaltige Medien und natürlich auch für Flüssigkeiten gefördert werden.

Sie ist sehr gut geeignet für enge Einbauverhältnisse, da kein Hebel auf- oder zugeklappt werden muß. Haupt Einsatzländer sind Frankreich, Spanien und Italien





The Guillemin coupling is the only symmetrical quick coupling in the DIN EN 14420 standard series. There are good reasons for its inclusion in this series of standards: The fitting can be coupled quickly and easily and can be secured against unintentional loosening by an adjusting ring. It is designed in such a way that one-sided loads do not damage the seal.

In contrast to the German EN14420-6 TW coupling, the Guillemin can also be tightened with a hook wrench. Its great advantage lies in its symmetrical design. It increases flexibility when connecting hose assemblies.

This saves considerable costs, as it is no longer necessary to pay attention to the

combination of male and female parts. MCC also offers a rotatable version of the coupling. This coupling should always be taken into consideration when systems are to be separated from each other by a combination of connection systems.

INFORMATION

Guillemin

WHY MCC?

- Long experience in the major Guillemin markets of France, Spain and Italy
- Complies with the strict NF E29-572 standard
- Fittings are also suitable for assemblies in accordance with IN EN 12115
- High availability and wide range of fittings (including rotatable versions)
- Wide range of accessories (e.g. gaskets)
- PFA lined couplings available (often used when flexibility and a higher continuous operating temperature range is required)



TECNICAL INFORMATIONS

- Standard: DIN EN 14420-8; NF E29-572
- Various connection options: serrated hose connectors for safety clamps, ISO 228 thread, welding end, composite hoses
- Size: DN 20 to DN 150
- Working pressure: -0,8 bis 6/10/16 bar at 65°C depending on material
- Material: Polypropylene, aluminium, brass, stainless steel
- Gaskets for coupling: NBR, FKM, EPDM, PTFE, Silicone, according to EU1935/2004, FDA
Thread Gaskets: PTFE, PU, FKM, EPDM, NBR, silicone, according to EU1935/2004, FDA

AREA OF APPLICATION

It can be used universally, but is mainly used for connection to tanker trucks. The robust design means that solids, media containing sediment and, of course, liquids can be pumped.

It is very well suited for tight installation conditions, as no lever has to be opened or closed. Main countries of use are France, Spain and Italy



**Guillemín Kupplung mit Rillenstutzen - mit Arretierung**

*mit Sicherungsbund

Guillemín coupling with serrated hose shank - with latch - *with collar

Raccord Guillemín avec verrou et douille annelée - *avec collerette

Guillemín para manguera con cierre - *con cuello de seguridad

Złącze Guillemín z karbowaną końcówką do węży - z pierścieniem blokującym *z wiązką zabezpieczającą

Guillemín con portagomma - con chiusura - *con collare di sicurezza

Part-No.	Material	WP	Dimension	Shank	Price
GH075AL20	Aluminum	16 bar	DN20	20mm	
GH075AL	Aluminum	16 bar	DN20	25mm	
GH100AL25	Aluminum	16 bar	DN25	25mm	
GH100AL	Aluminum	16 bar	DN25	30mm	
GH125AL	Aluminum	16 bar	DN32	35mm	
GH150AL35	Aluminum	16 bar	DN40	35mm	
GH150AL38	Aluminum	16 bar	DN40	38mm	
GH150AL*	Aluminum	16 bar	DN40	40mm	
GH150AL45	Aluminum	16 bar	DN40	45mm	
GH200AL*	Aluminum	16 bar	DN50	50mm	
GH200AL55	Aluminum	16 bar	DN50	55mm	
GH250AL*	Aluminum	16 bar	DN65	64mm	
GH250AL70	Aluminum	16 bar	DN65	70mm	
GH300AL*	Aluminum	16 bar	DN80	75mm	
GH300AL80*	Aluminum	16 bar	DN80	81mm	
GH300AL90	Aluminum	16 bar	DN80	90mm	
GH400AL100*	Aluminum	16 bar	DN100	100mm	
GH400AL102*	Aluminum	16 bar	DN100	102mm	
GH400AL110	Aluminum	16 bar	DN100	110mm	
GH500AL*	Aluminum	16 bar	DN125	125mm	
GH600AL*	Aluminum	16 bar	DN150	152mm	



Guillemin Kupplung mit drehbarem Rillenstutzen mit Arretierung

(auch gekuppelt drehbar) - *mit Sicherheitsbund

Guillemin coupling with swivel serrated hose shank (also coupled rotatable) - with latch - *with collar

Raccord Guillemin rotatif avec verrou et douille annelée (également couplé rotatif) - *avec collerette

Guillemin Giratorio para manguera con cierre (giratorio durante conexión) - *con cuello de seguridad

Złącze Guillemin z obrotową karbowaną końcówką do węża (również sprzężone obrotowo) - z pierścieniem blokującym - *z wiązką zabezpieczającą

Guillemin girevole con portagomma - con chiusura (anche accoppiato rotante) - *con collare di sicurezza



Part-No.	Material	WP	Dimension	Shank	Price
GH300AL76-SW*	Aluminum	16 bar	DN80	76mm	
GH300AL80-SW*	Aluminum	16 bar	DN80	80mm	
GH300AL90-SW	Aluminum	16 bar	DN80	90mm	
GH400AL100-SW*	Aluminum	16 bar	DN100	100mm	
GH400AL102-SW*	Aluminum	16 bar	DN100	102mm	
GH400AL110-SW	Aluminum	16 bar	DN100	110mm	

Guillemin Kupplung mit BSP Außengewinde - mit Arretierung

Guillemin coupling BSP male thread - with latch

Raccord Guillemin mâle BSP - à verrou

Guillemin con rosca macho BSP - con cierre

Złącze Guillemin z gwintem zewnętrznym BSP - z pierścieniem blokującym

Guillemin filetto maschio BSP - con chiusura



Part-No.	Material	WP	Dimension	Thread	Price
GML075AL	Aluminum	16 bar	DN20	3/4"	
GML100AL	Aluminum	16 bar	DN25	1"	
GML125AL	Aluminum	16 bar	DN32	1 1/4"	
GML150AL	Aluminum	16 bar	DN40	1 1/2"	
GML200AL	Aluminum	16 bar	DN50	2"	
GML250AL50	Aluminum	16 bar	DN65	2"	
GML250AL	Aluminum	16 bar	DN65	2 1/2"	
GML300AL	Aluminum	16 bar	DN80	3"	
GML400AL	Aluminum	16 bar	DN100	4"	
GML600AL	Aluminum	16 bar	DN150	6"	





Guillemín Kupplung mit BSP Innengewinde - mit Arretierung

Guillemín coupling with BSP female thread - with latch

Raccord Guillemín femelle BSP - à verrou

Guillemín con rosca hembra BSP - con cierre

Złącze Guillemín z gwintem wewnętrznym BSP - z pierścieniem blokującym

Guillemín filetto femmina BSP - con chiusura

Part-No.	Material	WP	Dimension	Thread	Price
GFL075AL	Aluminum	16 bar	DN20	3/4"	
GFL100AL	Aluminum	16 bar	DN25	1"	
GFL125AL	Aluminum	16 bar	DN32	1 1/4"	
GFL150AL	Aluminum	16 bar	DN40	1 1/2"	
GFL200AL40	Aluminum	16 bar	DN50	1 1/2"	
GFL200AL	Aluminum	16 bar	DN50	2"	
GFL250AL50	Aluminum	16 bar	DN65	2"	
GFL250AL	Aluminum	16 bar	DN65	2 1/2"	
GFL300AL65	Aluminum	16 bar	DN80	2 1/2"	
GFL300AL	Aluminum	16 bar	DN80	3"	
GFL400AL80	Aluminum	16 bar	DN100	3"	
GFL400AL	Aluminum	16 bar	DN100	4"	
GFL500AL	Aluminum	16 bar	DN125	5"	
GFL600AL	Aluminum	16 bar	DN150	6"	



Guillemín Kupplung mit drehbarem BSP Innengewinde - mit Arretierung

Guillemín coupling with swivel BSP female thread - with latch

Raccord Guillemín rotatif femelle BSP - à verrou

Guillemín giratorio rosca hembra BSP - con cierre

Złącze Guillemín z obrotową gwintem wewnętrznym BSP - z pierścieniem blokującym

Guillemín Girevole filetto femmina BSP - con chiusura

*Voller Durchfluss - eingeschränkt drehbar

*Full flow - Limited function of the swiveling

Part-No.	Material	WP	Dimension	Thread	Price
GFL300AL-SW	Aluminum	16 bar	DN80	3"	
GFL300AL-SWF*	Aluminum	16 bar	DN80	3"	
GFL400AL-SW	Aluminum	16 bar	DN100	4"	
GFL400AL-SWF*	Aluminum	16 bar	DN100	4"	



Guillemín Kupplung mit BSP Innengewinde - ohne Arretierung

Guillemín coupling with BSP female thread - without latch

Raccord Guillemín femelle BSP - sans verrou

Guillemín con rosca hembra BSP - Sin cierre

Złącze Guillemín z gwintem wewnętrznym BSP - bez pierścienia blokującego

Guillemín filetto femmina BSP - senza chiusura



Part-No.	Material	WP	Dimension	Thread	Price
GF075AL	Aluminum	16 bar	DN20	3/4"	
GF100AL	Aluminum	16 bar	DN25	1"	
GF125AL	Aluminum	16 bar	DN32	1 1/4"	
GF150AL	Aluminum	16 bar	DN40	1 1/2"	
GF200AL	Aluminum	16 bar	DN50	2"	
GF250AL	Aluminum	16 bar	DN65	2 1/2"	
GF300AL	Aluminum	16 bar	DN80	3"	
GF400AL	Aluminum	16 bar	DN100	4"	

Guillemín Kappe - mit Arretierung

Guillemín Cap - with latch

Raccord Guillemín bouchon et chaînette - à verrou

Tapón Guillemín - con cierre

Guillemín Korek - z pierścieniem blokującym

Tappo Guillemín - con chiusura



Part-No.	Material	WP	Dimension	Price
GBC075AL	Aluminum	16 bar	DN20	
GBC100AL	Aluminum	16 bar	DN25	
GBC125AL	Aluminum	16 bar	DN32	
GBC150AL	Aluminum	16 bar	DN40	
GBC200AL	Aluminum	16 bar	DN50	
GBC250AL	Aluminum	16 bar	DN65	
GBC300AL	Aluminum	16 bar	DN80	
GBC400AL	Aluminum	16 bar	DN100	
GBC600AL	Aluminum	16 bar	DN150	





Guillemín Stopfen - ohne Arretierung

Guillemín Plug - without latch
 Raccord Guillemín bouchon avec chaînette - sans verrou
 Tapón Guillemín - Sin cierre
 Guillemín Zaślepka - bez pierścienia blokującego
 Tappo Guillemín con maniglia e catena - senza chiusura

Part-No.	Material	WP	Dimension	Price
GC150AL	Aluminum	16 bar	DN40	
GC200AL	Aluminum	16 bar	DN50	
GC250AL	Aluminum	16 bar	DN65	
GC300AL	Aluminum	16 bar	DN80	
GC400AL	Aluminum	16 bar	DN100	



Guillemín Reduzierung - mit Arretierung

Guillemín reducer - with latch
 Jonction Double / Réduction Guillemín - à verrou
 Guillemín reducción - con cierre
 Redukcje Guillemín - z pierścieniem blokującym
 Guillemín riduzione - con chiusura

Part-No.	Material	WP	DN1	DN2	Price
GR150100AL	Aluminum	16 bar	DN40	DN25	
GR150125AL	Aluminum	16 bar	DN40	DN32	
GR200100AL	Aluminum	16 bar	DN50	DN25	
GR200150AL	Aluminum	16 bar	DN50	DN40	
GR250200AL	Aluminum	16 bar	DN65	DN50	
GR300150AL	Aluminum	16 bar	DN80	DN40	
GR300200AL	Aluminum	16 bar	DN80	DN50	
GR300250AL	Aluminum	16 bar	DN80	DN65	
GR400150AL	Aluminum	16 bar	DN100	DN40	
GR400200AL	Aluminum	16 bar	DN100	DN50	
GR400250AL	Aluminum	16 bar	DN100	DN65	
GR400300AL	Aluminum	16 bar	DN100	DN80	
GR600400AL	Aluminum	16 bar	DN150	DN100	



GFR auf Guillemin - mit Arretierung

GFR to Guillemin - with latch
 GFR et Guillemin - à verrou
 GFR a Guillemin - con cierre
 GFR z Guillemin - z pierścieniem blokującym
 GFR a Guillemin - con chiusurra

Part-No.	Material	WP	Guillemin	GFR	Price
GFRF300GL300AL	Aluminum	16 bar	DN80	Female DN80	
GFRM300GL300AL	Aluminum	16 bar	DN80	Male DN80	



Reduzierung IG/IG - mit kurzem Gewinde

Reduction female BSPP thread - with short thread
 Réduction double femelle/femelle - avec filetage court
 Reducción rosca hembra BSPP - con rosca corta
 Redukcja z gwintami - z krótkim gwintem
 Riduzione filettato femmina BSPP - con filo corto

Part-No.	Material	WP	Thread	Thread	Price
FFA2015	Aluminum	16 bar	2"	1 1/2"	
FFA2515	Aluminum	16 bar	2 1/2"	1 1/2"	
FFA2520	Aluminum	16 bar	2 1/2"	2"	
FFA3015	Aluminum	16 bar	3"	1 1/2"	
FFA3020	Aluminum	16 bar	3"	2"	
FFA3025	Aluminum	16 bar	3"	2 1/2"	
FFA4015	Aluminum	16 bar	4"	1 1/2"	
FFA4020	Aluminum	16 bar	4"	2"	
FFA4025	Aluminum	16 bar	4"	2 1/2"	
FFA4030	Aluminum	16 bar	4"	3"	



**Reduzierung IG/IG flachdichtend - NBR Dichtung**

Reducer female thread BSPP -female thread BSPP - NBR flat sealing

Réduction femelle/femelle à joint plat NBR

Reducción rosca hembra BSPP - rosca hembra BSPP - junta NBR

Redukcja z gwintami zewnętrznymi cylindrycznymi - NBR Uszczelka

Riduzione filettato femmina BSPP - filettato femmina BSPP - guarnizione NBR

Part-No.	Material	WP	Thread	Thread	Price
FFA6040FL	Aluminum		6"	4"	

**Guillemín Kupplung mit Rillenstutzen - mit Arretierung*****mit Sicherungsbund**

Guillemín coupling with serrated hose shank - with latch - *with collar

Raccord Guillemín avec verrou et douille annelée - *avec collerette

Guillemín para manguera con cierre - *con cuello de seguridad

Złącze Guillemín z karbowaną końcówką do węży - z pierścieniem blokującym *z wiązką zabezpieczającą

Guillemín con portagomma - con chiusura - *con collare di sicurezza

Part-No.	Material	WP	DN	Shank	Price
GH075SS	SS 1.4408	16 bar	DN20	25mm	
GH100SS	SS 1.4408	16 bar	DN25	30mm	
GH125SS	SS 1.4408	16 bar	DN32	35mm	
GH150SS*	SS 1.4408	16 bar	DN40	40mm	
NEW GH150SS38*	SS 1.4408	16 bar	DN40	38mm	
GH150SS45	SS 1.4408	16 bar	DN40	45mm	
GH200SS*	SS 1.4408	16 bar	DN50	50mm	
GH250SS*	SS 1.4408	16 bar	DN65	64mm	
GH250SS70	SS 1.4408	16 bar	DN65	70mm	
GH300SS*	SS 1.4408	16 bar	DN80	76mm	
GH300SS80	SS 1.4408	16 bar	DN80	80mm	
GH300SS90	SS 1.4408	16 bar	DN80	90mm	
GH400SS*	SS 1.4408	16 bar	DN100	101,6mm	
GH400SS110	SS 1.4408	16 bar	DN100	110mm	



Guillemin Kupplung mit Rillenstutzen - mit Arretierung

und Sicherungsbund - PFA ausgekleidet

Guillemin coupling with serrated hose shank - with latch - with collar - PFA coated

Raccord Guillemin à douille annelée - à verrou - avec collerette - revêtue de PFA

Guillemin para manguera con cierre - con cuello de seguridad - Recubierto de PF

Złącze Guillemin z karbowaną końcówką do węża - z pierścieniem blokującym - z wiązka zabezpieczającą Z powłoką PFA

Guillemin con portagomma - con chiusura - con collare di sicurezza - Rivestimento in PFA

NEW

Part-No.	Material	WP	Dimension	Shank	Price
GH125SSPFA-W	SS 1.4408 PFA white coated	16 bar	DN32	32mm	
GH150SSPFA-W	SS 1.4408 PFA white coated	16 bar	DN40	38mm	
GH200SSPFA-W	SS 1.4408 PFA white coated	16 bar	DN50	50mm	
GH200SSPFA-B	SS 1.4408 PFA black coated	16 bar	DN50	50mm	
GH300SSPFA-B	SS 1.4408 PFA black coated	16 bar	DN80	76mm	
GH400SSPFA-B	SS 1.4408 PFA black coated	16 bar	DN100	100mm	

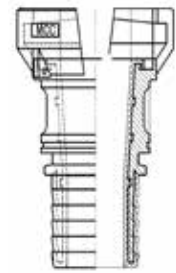
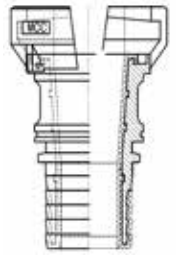

Ω
CONDUCTIVE

Guillemin Kupplung mit Rillenstutzen, abschließbar - mit Arretierung

Guillemin coupling with serrated hose shank - Lockable with extra lock - with latch

Raccord Guillemin à douille annelée avec une serrure supplémentaire - à verrou

Guillemin para manguera con cierre - se puede bloquear con una cerradura adicional - con cierre

Złącze Guillemin z karbowaną końcówką do węża - dodatkowy zamek - z pierścieniem blokującym

Guillemin con portagomma - con chiusura - con un lucchetto aggiuntivo - con chiusura

NEW

Part-No.	Material	WP	Dimension	Shank	Price
GH300SS-H	SS 1.4408	16 bar	DN80	76mm	





Guillemín Kupplung mit BSP Außengewinde - mit Arretierung

Guillemín coupling with BSP male thread - with latch

Raccord Guillemín mâle BSP - à verrou

Guillemín con rosca macho BSP - con cierre

Złącze Guillemín z gwintem zewnętrznym BSP - z pierścieniem blokującym

Guillemín filetto maschio BSP - con chiusura

Part-No.	Material	WP	DN	Thread	Price
GML075SS	SS 1.4408	16 bar	DN20	3/4"	
GML100SS	SS 1.4408	16 bar	DN25	1"	
GML125SS	SS 1.4408	16 bar	DN32	1 1/4"	
GML150SS	SS 1.4408	16 bar	DN40	1 1/2"	
GML200SS	SS 1.4408	16 bar	DN50	2"	
GML250SS	SS 1.4408	16 bar	DN65	2 1/2"	
GML300SS	SS 1.4408	16 bar	DN80	3"	
GML400SS	SS 1.4408	16 bar	DN100	4"	



Guillemín Kupplung mit BSP Außengewinde - ohne Arretierung

Guillemín coupling with BSP male thread - without latch

Raccord Guillemín mâle BSP - sans verrou

Guillemín con rosca macho BSP - Sin cierre

Złącze Guillemín z gwintem zewnętrznym BSP - bez pierścienia blokującego

Guillemín filetto maschio BSP - senza chiusura

Part-No.	Material	WP	DN	Thread	Price
GM075SS	SS 1.4408	16 bar	DN20	3/4"	
GM100SS	SS 1.4408	16 bar	DN25	1"	
GM125SS	SS 1.4408	16 bar	DN32	1 1/4"	
GM150SS	SS 1.4408	16 bar	DN40	1 1/2"	
GM200SS	SS 1.4408	16 bar	DN50	2"	
GM250SS	SS 1.4408	16 bar	DN65	2 1/2"	
GM300SS	SS 1.4408	16 bar	DN80	3"	
GM400SS	SS 1.4408	16 bar	DN100	4"	



Guillemin Kupplung mit BSP Innengewinde - mit Arretierung

Guillemin coupling with BSP female thread - with latch

Raccord Guillemin femelle BSP - à verrou

Guillemin con rosca hembra BSP - con cierre

Złącze Guillemin z gwintem wewnętrznym BSP - z pierścieniem blokującym

Guillemin filetto femmina BSP - con chiusura



Part-No.	Material	WP	DN	Thread	Price
GFL075SS	SS 1.4408	16 bar	DN20	3/4"	
GFL100SS	SS 1.4408	16 bar	DN25	1"	
GFL125SS	SS 1.4408	16 bar	DN32	1 1/4"	
GFL150SS	SS 1.4408	16 bar	DN40	1 1/2"	
GFL200SS	SS 1.4408	16 bar	DN50	2"	
GFL250SS	SS 1.4408	16 bar	DN65	2 1/2"	
GFL300SS	SS 1.4408	16 bar	DN80	3"	
GFL400SS	SS 1.4408	16 bar	DN100	4"	

Guillemin Kupplung mit BSP Innengewinde, abschließbar - mit Arretierung

Guillemin coupling with BSP female thread - lockable with extra lock - with latch

Raccord Guillemin femelle BSP avec une serrure supplémentaire - à verrou

Guillemin con rosca hembra BSP - con cerradura adicional - con cierre

Złącze Guillemin z gwintem wewnętrznym BSP- dodatkowy zamek - z pierścieniem blokującym

Guillemin filetto femmina BSP con un lucchetto aggiuntivo - con chiusura

**NEW**

Part-No.	Material	WP	DN	Thread	Price
GFL300SS-H	SS 1.4408	16 bar	DN80	3"	

Guillemin Kupplung mit drehbarem BSP Innengewinde - mit Arretierung

Guillemin coupling with swivel BSP female thread - with latch

Raccord Guillemin rotatif femelle BSP - à verrou

Guillemin giratorio rosca hembra BSP - con cierre

Złącze Guillemin z obrotową gwintem wewnętrznym BSP - z pierścieniem blokującym

Guillemin Girevole filetto femmina BSP - con chiusura



Part-No.	Material	WP	DN	Thread	Price
GFL300SS-SW	SS 1.4408	16 bar	DN80	3"	





Guillemín Kupplung mit BSP Innengewinde - ohne Arretierung

Guillemín coupling with BSP female thread - without latch

Raccord Guillemín femelle BSP - sans verrou

Guillemín con rosca hembra BSP - Sin cierre

Złącze Guillemín z gwintem wewnętrznym BSP - bez pierścienia blokującego

Guillemín filetto femmina BSP - senza chiusura

Part-No.	Material	WP	DN	Thread	Price
GF075SS	SS 1.4408	16 bar	DN20	3/4"	
GF100SS	SS 1.4408	16 bar	DN25	1"	
GF125SS	SS 1.4408	16 bar	DN32	1 1/4"	
GF150SS	SS 1.4408	16 bar	DN40	1 1/2"	
GF200SS	SS 1.4408	16 bar	DN50	2"	
GF250SS	SS 1.4408	16 bar	DN65	2 1/2"	
GF300SS	SS 1.4408	16 bar	DN80	3"	
GF400SS	SS 1.4408	16 bar	DN100	4"	



Guillemín Kappe - mit Arretierung

Guillemín Cap - with latch

Raccord Guillemín bouchon et chaînette - à verrou

Tapón Guillemín - con cierre

Guillemín Korek - z pierścieniem blokującym

Tappo Guillemín con catena - con chiusura

*ohne Arretierung
* without latch

Part-No.	Material	WP	DN	Price
GBC075SS*	SS 1.4408	16 bar	DN20	
GBC100SS*	SS 1.4408	16 bar	DN25	
GBC125SS*	SS 1.4408	16 bar	DN32	
GBC150SS	SS 1.4408	16 bar	DN40	
GBC200SS	SS 1.4408	16 bar	DN50	
GBC250SS	SS 1.4408	16 bar	DN65	
GBC300SS	SS 1.4408	16 bar	DN80	
GBC400SS	SS 1.4408	16 bar	DN100	



Guillemin Kappe - ohne Arretierung

Guillemin Cap - without latch

Raccord Guillemin bouchon et chaînette - sans verrou

Tapón Guillemin - Sin cierre

Guillemin Korek - bez pierścienia blokującego

Tappo Guillemin con catena - senza chiusura



Part-No.	Material	WP	DN	Price
GLC200SS	SS 1.4408	16 bar	DN50	
GLC300SS	SS 1.4408	16 bar	DN80	

Guillemin Reduzierung - mit Arretierung

Guillemin reducer - with latch

Jonction Double / Réduction Guillemin - à verrou

Guillemin reducci3n - con cierre

Redukcja Guillemin - z pierścieniem blokującym

Guillemin riduzione - con chiusura



Part-No.	Material	WP	DN1	DN2	Price
GR200150SS	SS 1.4408	16 bar	DN50	DN40	
GR250150SS	SS 1.4408	16 bar	DN65	DN40	
GR250200SS	SS 1.4408	16 bar	DN65	DN50	
GR300200SS	SS 1.4408	16 bar	DN80	DN50	
GR300250SS	SS 1.4408	16 bar	DN80	DN65	
GR400200SS	SS 1.4408	16 bar	DN100	DN50	
GR400300SS	SS 1.4408	16 bar	DN100	DN80	





Guillemín mit Anschweißende - mit Arretierung

Guillemín with welding end - with latch

Guillemín à souder - à verrou

Guillemín para soldar - con cierre

Guillemín z końcówką do spawania - z pierścieniem blokującym

Guillemín a saldare - con chiusura

Part-No.	Material	WP	DN	BW	Price
GFL150SSBW	SS 1.4408	16 bar	DN40	48,3mm	
GFL200SSBW	SS 1.4408	16 bar	DN50	60,3mm	
GFL300SSBW	SS 1.4408	16 bar	DN80	88,9mm	
GFL400SSBW	SS 1.4408	16 bar	DN100	114,3mm	



Guillemín Kupplung mit Rillenstutzen - mit Arretierung

*mit Sicherungsbund

Guillemín coupling with serrated hose shank - with latch - *with collar

Raccord Guillemín avec verrou et douille annelée - *avec collerette

Guillemín para manguera con cierre - *con cuello de seguridad

Złącze Guillemín z karbowaną końcówką do węży - z pierścieniem blokującym *z wiązką zabezpieczającą

Guillemín con portagomma - con chiusura - *con collare di sicurezza

Part-No.	Material	WP	DN	Shank	Price
GH200BR*	Brass	16 bar	DN50	50mm	
GH300BR*	Brass	16 bar	DN80	76mm	
GH300BR80*	Brass	16 bar	DN80	80mm	
GH300BR90	Brass	16 bar	DN80	90mm	



Guillemin Kupplung mit BSP Außengewinde - mit Arretierung

Guillemin coupling with BSP male thread - with latch

Raccord Guillemin mâle BSP - à verrou

Guillemin con rosca macho BSP - con cierre

Złącze Guillemin z gwintem zewnętrznym BSP - z pierścieniem blokującym

Guillemin filetto maschio BSP - con chiusura



Part-No.	Material	WP	DN	Thread	Price
GML150BR	Brass	16 bar	DN40	1 1/2"	
GML200BR	Brass	16 bar	DN50	2"	
GML300BR	Brass	16 bar	DN80	3"	
GML400BR	Brass	16 bar	DN100	4"	

Guillemin Kupplung mit BSP Außengewinde - ohne Arretierung

Guillemin coupling with BSP male thread - without latch

Raccord Guillemin mâle BSP - sans verrou

Guillemin con rosca macho BSP - sin cierre

Złącze Guillemin z gwintem zewnętrznym BSP - bez pierścienia blokującego

Guillemin filetto maschio BSP - senza chiusura



Part-No.	Material	WP	DN	Thread	Price
GM125BR	Brass	16 bar	DN32	1 1/4"	
GM150BR	Brass	16 bar	DN40	1 1/2"	
GM200BR	Brass	16 bar	DN50	2"	
GM300BR	Brass	16 bar	DN80	3"	
GM400BR	Brass	16 bar	DN100	4"	





Guillemín Kupplung mit BSP Innengewinde - mit Arretierung

Guillemín coupling with BSP female thread - with latch

Raccord Guillemín femelle BSP - à verrou

Guillemín con rosca hembra BSP - con cierre

Złącze Guillemín z gwintem wewnętrznym BSP - z pierścieniem blokującym

Guillemín filetto femmina BSP - con chiusura

Part-No.	Material	WP	DN	Thread	Price
GFL150BR	Brass	16 bar	DN40	1 1/2"	
GFL200BR	Brass	16 bar	DN50	2"	
GFL250BR	Brass	16 bar	DN65	2 1/2"	
GFL300BR	Brass	16 bar	DN80	3"	
GFL400BR	Brass	16 bar	DN100	4"	



Guillemín Kupplung mit BSP Innengewinde - ohne Arretierung

Guillemín coupling with BSP female thread - without latch

Raccord Guillemín femelle BSP - sans verrou

Guillemín con rosca hembra BSP - sin cierre

Złącze Guillemín z gwintem wewnętrznym BSP - bez pierścienia blokującego

Guillemín filetto femmina BSP - senza chiusura

Part-No.	Material	WP	DN	Thread	Price
GF125BR	Brass	16 bar	DN32	1 1/4"	
GF150BR	Brass	16 bar	DN40	1 1/2"	
GF200BR	Brass	16 bar	DN50	2"	
GF300BR	Brass	16 bar	DN80	3"	
GF400BR	Brass	16 bar	DN100	4"	



Guillemin Kappe - mit Arretierung

Guillemin Cap - with latch
 Raccord Guillemin bouchon et chaînette - à verrou
 Tapón Guillemin - con cierre
 Guillemin Korek - z pierścieniem blokującym
 Tappo Guillemin con catena - con chiusuraa



Part-No.	Material	WP	DN	Price
GBC150BR	Brass	16 bar	DN40	
GBC200BR	Brass	16 bar	DN50	
GBC300BR	Brass	16 bar	DN80	
GBC400BR	Brass	16 bar	DN100	

Guillemin Kappe - ohne Arretierung

Guillemin Cap - without latch
 Raccord Guillemin bouchon et chaînette - sans verrou
 Tapón Guillemin - sin cierre
 Guillemin Korek - bez pierścienia blokującego
 Tappo Guillemin con catena - senza chiusura



Part-No.	Material	WP	DN	Price
GLC150BR	Brass	16 bar	DN40	

Guillemin Reduzierung - mit Arretierung

Guillemin reducer - with latch
 Jonction Double / Réduction Guillemin - à verrou
 Guillemin reducción - con cierre
 Redukcje Guillemin - z pierścieniem blokującym
 Guillemin riduzione - con chiusura



Part-No.	Material	WP	DN	Thread	Price
GR300200BR	Brass	16 bar	DN80	DN50	
GR300250BR	Brass	16 bar	DN80	DN65	
GR400300BR	Brass	16 bar	DN100	DN80	





Guillemín Kupplung mit Rillenstutzen - mit Arretierung

Guillemín coupling with serrated hose shank - with latch

Raccord Guillemín à douille annelée - à verrou

Guillemín para manguera y espiga dentada - con cierre

Złącze Guillemín z karbowaną końcówką do węża- z pierścieniem blokującym

Guillemín con portagomma - con chiusura

Part-No.	Material	WP	DN	Shank	Price
GH150PP	Polypropylene	6 bar	DN40	40mm	
GH200PP	Polypropylene	6 bar	DN50	51mm	
GH300PP	Polypropylene	6 bar	DN80	76mm	
GH400PP	Polypropylene	6 bar	DN100	102mm	



Guillemín Kupplung mit BSP Außengewinde - mit Arretierung

Guillemín coupling with BSP male thread - with latch

Raccord Guillemín mâle BSP - à verrou

Guillemín con rosca macho BSP - con cierre

Złącze Guillemín z gwintem zewnętrznym BSP - z pierścieniem blokującym

Guillemín filetto maschio BSP con chiusura

Part-No.	Material	WP	DN	Thread	Price
GML150PP	Polypropylene	6 bar	DN40	1 1/2"	
GML200PP	Polypropylene	6 bar	DN50	2"	
GML300PP	Polypropylene	6 bar	DN80	3"	
GML400PP	Polypropylene	6 bar	DN100	4"	



Guillemin Kupplung mit BSP Innengewinde - mit Arretierung

Guillemin coupling with BSP female thread - with latch
 Raccord Guillemin femelle BSP - à verrou
 Guillemin con rosca hembra BSP - con cierre
 Złącze Guillemin z gwintem wewnętrznym BSP - z pierścieniem blokującym
 Guillemin filetto femmina BSP - con chiusura



Part-No.	Material	WP	DN	Thread	Price
GFL150PP	Polypropylene	6 bar	DN40	1 1/2"	
GFL200PP	Polypropylene	6 bar	DN50	2"	
GFL300PP	Polypropylene	6 bar	DN80	3"	
GFL400PP	Polypropylene	6 bar	DN100	4"	

Guillemin Kappe - ohne Arretierung

Guillemin Cap - without latch
 Raccord Guillemin bouchon et chaînette - sans verrou
 Tapón Guillemin - à verrou
 Guillemin Korek - bez pierścienia blokującego
 Tappo guillemin - senza chiusura



Part-No.	Material	WP	DN	Price
GLC150PP	Polypropylene	6 bar	DN40	
GLC200PP	Polypropylene	6 bar	DN50	
GLC300PP	Polypropylene	6 bar	DN80	
GLC400PP	Polypropylene	6 bar	DN100	

Guillemin Reduzierung - mit Arretierung

Guillemin reducer - with latch
 Réduction Guillemin - à verrou
 Guillemin reducción - con cierre
 Redukcje Guillemin - z pierścieniem blokującym
 Guillemin riduzione - con chiusura



Part-No.	Material	WP	DN1	DN2	Price
GR300200PP	Polypropylene	6 bar	DN80	DN50	
GR400300PP	Polypropylene	6 bar	DN100	DN80	





Schauglas mit beidseitigem BSPP Außengewinde, Material PC

Sight glass with both sides BSPP male thread, polycarbonate

Tube transparent Filetage mâle BSPP des deux côtés, polycarbonate

Mirilla con rosca macho BSPP en ambos lados, material PC

Tubo transparente rosca macho BSPP en ambos lados, policarbonato

Tubo trasparente con filetto maschio BSPP su entrambi i lati, policarbonato

Part-No.	Material	WP	Thread	Thread	Length	Price
SGBSPM200	Polycarbonate	10 bar	2"	2"	200mm	
SGBSPM300	Polycarbonate	10 bar	3"	3"	200mm	
SGBSPM400	Polycarbonate	10 bar	4"	4"	200mm	



Vorhängeschloss für abschließbare Kupplungen

Padlock

Cadenas

Candado

Kłódka z

Lucchetto

Part-No.	Material	Description	Price
LOCKSS	SS304	Padlock in SS304 with keys	
LOCKSS2	SS304	Padlock in SS304 with keys (long bolt)	
LOCKBR	Brass	Padlock in brass with keys	



DSP Kupplung mit Rillenstutzen - mit Arretierung

DSP coupling with serrated hose shank - with latch
 Raccord DSP à douille annelée - à verrou
 DSP con espiga dentada para manguera - con cierre
 Złącze DSP z karbowaną końcówką do węża - z pierścieniem blokującym
 Raccordo DSP con portagomma a resca - con chiusura



Part-No.	Material	WP	DN	Shank	Price
DSPH150AL45	Aluminum	16 bar	DN40	45mm	
DSPH250AL70	Aluminum	16 bar	DN65	70mm	

DSP Kupplung mit Stutzen - mit Arretierung

DSP coupling with grooved hose shank - with latch
 Raccord DSP à douille annelée - à verrou
 DSP con espiga para manguera - con cierre
 Złącze DSP z gładką końcówką do węża z pierścieniem blokującym - z pierścieniem blokującym
 Raccordi DSP con portagomma - con chiusura



Part-No.	Material	WP	DN	Shank	Price
DSPH150AL45G	Aluminum	16 bar	DN40	45mm	
DSPH250AL70G	Aluminum	16 bar	DN65	70mm	

DSP Kupplung mit BSP Innengewinde - mit Arretierung

DSP coupling with BSP female thread - with latch
 Raccord DSP femelle BSP - à verrou
 DSP con rosca hembra BSP - con cierre
 Złącze DSP z gwintem wewnętrznym BSP - z pierścieniem blokującym
 Raccordi DSP con filettatura femmina BSP - con chiusura



Part-No.	Material	WP	DN	Thread	Price
DSPF40AL	Aluminum	16 bar	DN40	1 1/2"	
DSPF40AL50	Aluminum	16 bar	DN40	2"	
DSPF65AL	Aluminum	16 bar	DN65	2 1/2"	





DSP Kupplung mit BSP Innengewinde - ohne Arretierung

DSP coupling with BSP female thread - without latch
 Raccord DSP femelle BSP - sans verrou
 DSP con rosca hembra BSP - sin cierre
 Złącze DSP z gwintem wewnętrznym BSP - bez pierścienia blokującego
 Raccordi DSP con filettatura femmina BSP - senza chiusura

Part-No.	Material	WP	DN	Thread	Price
DSPFS40AL	Aluminum	16 bar	DN40	1 1/2"	
DSPFS40AL50	Aluminum	16 bar	DN40	2"	
DSPFS65AL	Aluminum	16 bar	DN65	2 1/2"	



DSP Kupplung mit BSP Außengewinde - mit Arretierung

DSP coupling with BSP male thread - with latch
 Raccord DSP mâle BSP - à verrou
 DSP con rosca macho BSP - con cierre
 Złącze DSP z gwintem zewnętrznym BSP - z pierścieniem blokującym
 Raccordi DSP con filettatura maschio BSP - con chiusura

Part-No.	Material	WP	DN	Thread	Price
DSPM40AL	Aluminum	16 bar	DN40	1 1/2"	
DSPM40AL50	Aluminum	16 bar	DN40	2"	
DSPM65AL	Aluminum	16 bar	DN65	2 1/2"	



DSP Kupplung mit BSP Außengewinde - ohne Arretierung

DSP coupling with BSP male thread - without latch
 Raccord DSP mâle BSP - sans verrou
 DSP con rosca macho BSP - sin cierre
 Złącze DSP z gwintem zewnętrznym BSP - bez pierścienia blokującego
 Raccordi DSP con filettatura maschio BSP - senza chiusura

Part-No.	Material	WP	DN	Thread	Price
DSPMS40AL	Aluminum	16 bar	DN40	1 1/2"	
DSPMS40AL50	Aluminum	16 bar	DN40	2"	
DSPMS65AL	Aluminum	16 bar	DN65	2 1/2"	



DSP Blindkappe - mit Arretierung

DSP cap - with latch

Raccord DSP bouchon et chaînette - à verrou

Tapón DSP - con cierre

DSP Korek - z pierścieniem blokującym

Tappo DSP - con chiusura



Part-No.	Material	WP	DN	Price
DSPB40AL	Aluminum	16 bar	DN40	
DSPB65AL	Aluminum	16 bar	DN65	



INFORMATIONEN

Storz Kupplung



Die Storz Armatur ist geordnet nach Nennweiten in einer Normgruppe (DIN 143xx) normiert. Sie ist eine symmetrische Schnellkupplung. Zum Schließen wird sie ineinander gedreht, wobei bei dieser Verdrehung auch die Dichtungen aneinandergespreßt werden. Die hohen Drehkräfte erfordern gerade bei größeren Nennweiten ein Werkzeug oder einen

Hakenschlüssel, um beide Hälften miteinander zu koppeln.

Die Bestimmung der richtigen Kupplung orientiert am Knaggen Abstand. Die größte Nennweite (Typ A) leitet sich aus dem lichten Innendurchmesser von 4" Rohren ab, Die Type B an 3"-, die Type „C“ an 2“- und die Type A an 1“-Rohren.

Die verschiedenen Ausführungsformen bei der Befestigung an Rohrleitungsenden oder am Schlauchende bieten innerhalb der jeweiligen Nennweite eine sehr hohe Variantenvielfalt, die durch unterschiedliche Werkstoffe der Kupplung und der Dichtungstypen ergänzt wird.

WARUM MCC?

- Präzise Nockenführung ermöglicht einfaches Kuppeln
- Festigkeit der geschmiedeten MCC-Armatur übertrifft die in der DIN Norm geforderten Werte deutlich
- Vielfältige Ausführungen (drehbare Systeme, Hebelvarianten oder Sperrklinken)
- Passgenaue Dichtungen für jedes Einsatzgebiet (auch in Lebensmittelqualität)
- Hohe Anzahl an Nennweiten verfügbar mit verschiedensten Schlauchanschlüssen, Reduzierungen oder auch erforderlicher Verschlusskappen-Systeme
- Edelstahl Kupplungen aus 1.4581



TECHNISCHE INFORMATIONEN

- Normen: DIN EN 14300 bis DIN 14330
- Gewindeanschlüsse: ISO 228 flachdichtend (Abmessungen Gewindelänge bzw. Gewindetiefe vergleichbar DIN EN 14420-5)
- Schlauchstutzen: auch nach DIN 14420-2, nach o.g. Normen sowie weitere Typen
- Betriebsdruck: -0,8 bis 25 bar bei 65°C
- Armaturenwerkstoffe: Aluminium, Messing, Edelstahl 1.4581
- Kupplungsdichtungen: NBR, FKM, Silikon, nach EU1935/2004, FDA für Lebensmittel

Gewindedichtungen: PTFE, PU, FKM, EPDM, NBR, Silikon, nach EU1935/2004, FDA für Lebensmittel

EINSATZGEBIET

Die Aluminium Storz -Armatur ist die deutsche Standardarmatur beim Verbinden von Wasserleitungen im Brandschutz, Silotransport und im Baugewerbe, da hier die Anforderungen für Druckfestigkeit und Dichtigkeit geringer sind. Aus Edelstahl wird sie unter anderem in der Getränke- und Lebensmittelindustrie eingesetzt. Symmetrische Kupplungen bieten den Vorteil, dass sie immer untereinander kuppelbar sind. Das Storz System ist eher für größere Nennweiten ab DN25 und für Flüssigkeiten geeignet.

Für kleinere Nennweiten werden andere hier im Katalog aufgeführten Klauenkupplungen verwendet.

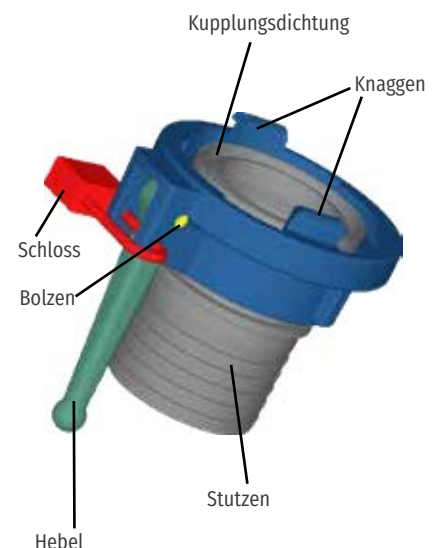



INFORMATION

Storz Coupling

The Storz coupling is nominated according to nominal diameter in a standard group (DIN 143xx). It is a symmetrical quick coupling.

To close it, it is twisted into each other, whereby the gasket are pressed together during this twisting. The high torsional forces require a tool or a hook wrench to

couple the two halves together.

The correct coupling is determined by the distance between the cleats. The largest nominal width (type A) is derived from the clear inside diameter of 4" pipes, type B on 3" pipes, type "C" on 2" pipes and type A on 1" pipes.

The different designs for attachment to

pipe ends or hose ends offer a very wide range of variants within the respective nominal diameter, which is supplemented by different coupling materials and gasket types.

WHY MCC?

- Präzise Nockenführung ermöglicht einfaches Kuppeln
- Strength of the forged significantly exceeds the values required by the DIN standard
- Wide range of designs (rotating systems, lever variants or pawls)
- Precisely fitting gasket for every area of application (also in food quality)
- Large number of nominal widths available with a wide range of hose connections, reducers or required sealing cap systems
- Stainless steel couplings made from 1.4581



TECHNICAL INFORMATIONS

- Norm: DIN EN 14300 to DIN 14330
- Thread: ISO 228 flat-sealing (dimensions thread length or thread depth comparable to DIN EN 14420-5)
- Hose shanks: also to DIN 14420-2, to the above standards and other types
- Working pressure: -0,8 to 25 bar at 65°C
- Material: aluminium, brass, stainless steel 1.4581
- Gaskets for coupling: NBR, FKM, silicone, according to EU1935/2004, FDA for food application
Thread Gaskets: PTFE, PU, FKM, EPDM, NBR, silicone, according to

EU1935/2004, FDA for application

AREA OF APPLICATION

The aluminum Storz fitting is the German standard fitting for connecting water pipes in fire protection, silo transport and the construction industry, as the requirements for pressure resistance and tightness are lower here.

Made of stainless steel, it is used in the food and beverage industry, among others. Symmetrical couplings offer the advantage that they can always be coupled together.

The Storz system is more suitable for larger nominal diameters from DN25 and for liquids.

Other claw couplings listed in this catalog are used for smaller nominal diameters.

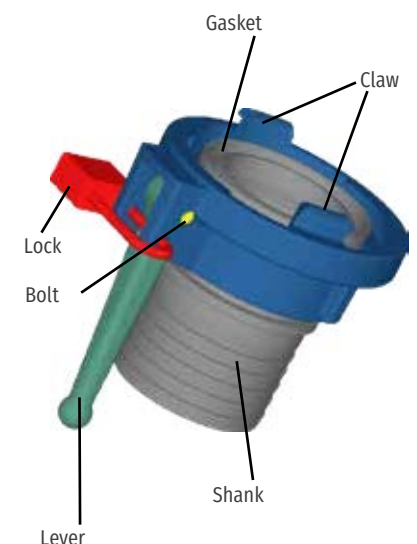



Storz-Kupplung mit langem Stutzen (Saug/Druck)

DIN geschmiedet - mit NBR Dichtung

Storz coupling with serrated hose shank (DIN) - NBR gasket

Raccord Storz à douille annelée - Joint NBR

Acople Storz con espiga para manguera (forjado) - Junta NBR

Złącze strażackie STORZ z długą karbowaną końcówką do węża (ssawno/tłoczna) - (wykuty) - NBR Uszczelka

Raccordo Storz portagomma (forgiato) - guarnizione in NBR

NEW

Part-No.	Material	WP	DN/KA	Shank	Price
ST25/25DINLST	Aluminum forged	16 bar	DN25(D)/31mm	DN25	
ST38/32DINLST	Aluminum forged	16 bar	DN38/51mm	DN32	
ST38/38DINLST	Aluminum forged	16 bar	DN38/51mm	DN38	
ST52/32DINLST	Aluminum forged	16 bar	DN52(C)/66mm	DN32	
ST52/38DINLST	Aluminum forged	16 bar	DN52(C)/66mm	DN38	
ST52/45DINLST	Aluminum forged	16 bar	DN52(C)/66mm	DN45	
ST52/52DINLST	Aluminum forged	16 bar	DN52(C)/66mm	DN52	
ST65/25DINLST	Aluminum forged	16 bar	DN65/81mm	DN25	
ST65/32DINLST	Aluminum forged	16 bar	DN65/81mm	DN32	
ST65/38DINLST	Aluminum forged	16 bar	DN65/81mm	DN38	
ST65/52DINLST	Aluminum forged	16 bar	DN65/81mm	DN52	
ST65/63DINLST	Aluminum forged	16 bar	DN65/81mm	DN63	
ST75/52DINLST	Aluminum forged	16 bar	DN75(B)/89mm	DN52	
ST75/63DINLST	Aluminum forged	16 bar	DN75(B)/89mm	DN63	
ST75/75DINLST	Aluminum forged	16 bar	DN75(B)/89mm	DN75	
ST100/100DINLST	Aluminum forged	16 bar	DN100/115mm	DN100	
ST110/100DINLST	Aluminum forged	16 bar	DN110(A)/133mm	DN100	
ST110/110DINLST	Aluminum forged	16 bar	DN110(A)/133mm	DN110	
ST125/125DINLST	Aluminum forged	16 bar	DN125/148mm	DN125	
ST150/150DINLST	Aluminum forged	16 bar	DN150/160mm	DN150	



Storz-Kupplung mit glattem Stutzen und Sicherungsbund

DIN geschmiedet - mit NBR Dichtung

Storz coupling with smooth hose shank with collar - (DIN) - NBR gasket

Raccord Storz à douille lisse et collerette - Joint NBR

Acople Storz con espiga lisa para abrazaderas de seguridad - (forjado) - Junta NBR

Złącze strażackie STORZ z gładką końcówką do węża pod obejmę skorupową (DIN wykuty) - NBR Uszczelka

Raccordo Storz portagomma liscio (DIN forgiato) - Guarnizione NBR



Part-No.	Material	WP	DN/KA	Shank	Price
ST52/25DINLSTG	Aluminum forged	16 bar	DN52(C)/66mm	DN25	
ST52/50DINLSTG	Aluminum forged	16 bar	DN52(C)/66mm	DN50	
ST75/75DINLSTG	Aluminum forged	16 bar	DN75(B)/89mm	DN75	
ST110/100DINLSTG	Aluminum forged	16 bar	DN110(A)/133mm	DN100	

NEW

Storz-Kupplung mit Sägezahnprofilstutzen und Sicherungsbund

DIN geschmiedet - mit NBR Dichtung

Storz coupling with serrated hose shank with collar - (DIN) - NBR gasket

Raccord Storz à douille annelée - Joint NBR

Acople Storz con espiga dentada para abrazaderas de seguridad - (forjado) - Junta NBR

Złącze strażackie STORZ z karbowaną końcówką do węża pod obejmę skorupową (DIN wykuty) - NBR Uszczelka

Raccordo Storz portagomma (DIN forgiato) - Guarnizione NBR



Part-No.	Material	WP	DN/KA	Shank	Price
ST52/52DINLST-SZ	Aluminum forged	16 bar	DN52(C)/66mm	DN50	
ST75/75DINLST-SZ	Aluminum forged	16 bar	DN75(B)/89mm	DN75	
ST110/100DINLST-SZ	Aluminum forged	16 bar	DN110(A)/133mm	DN100	

Storz-Kupplung mit Sägezahnprofilstutzen ohne Sicherungsbund

DIN geschmiedet - mit NBR Dichtung

Storz coupling with serrated hose shank without collar - NBR gasket

Raccord Storz à douille annelée - Joint NBR

Acople Storz con espiga dentada - (forjado) - Junta NBR

Złącze strażackie STORZ z karbowaną końcówką do węża (DIN wykuty) - NBR Uszczelka

Raccordo Storz portagomma (DIN forgiato) - Guarnizione NBR



Part-No.	Material	WP	DN/KA	Shank	Price
ST52/52DINLST-SZO	Aluminum forged	16 bar	DN52(C)/66mm	DN50	
ST75/75DINLST-SZO	Aluminum forged	16 bar	DN75(B)/89mm	DN75	
ST100/100DINLST-SZO	Aluminum forged	16 bar	DN100/115mm	DN100	
ST110/100DINLST-SZO	Aluminum forged	16 bar	DN110(A)/133mm	DN100	





Storz-Kupplung mit Sägezahnprofilstutzen (aus Stahl) mit Sicherungsbund

DIN geschmiedet - mit NBR Dichtung

Storz coupling with serrated hose shank with collar - NBR gasket

Raccord Storz à douille annelée - Joint NBR

Acople Storz con espiga para manguera en acero y acople en aluminio (forjado) - Junta NBR

Złącze strażackie STORZ z karbowaną końcówką do węża pod obejmę skorupową (DIN wykuty) - NBR Uszczelka

Raccordo Storz con portagomma in acciaio ed accoppiamento in alluminio (DIN forgiato) - Guarnizione NBR

Part-No.	Material	WP	DN/KA	Shank	Price
ST52/52DINLST-ACSZ	Coupling AL forged - Shank Steel	16 bar	DN52(C)/66mm	DN50	
ST75/75DINLST-ACSZ	Coupling AL forged - Shank Steel	16 bar	DN75(B)/89mm	DN75	
ST110/100DINLST-ACSZ	Coupling AL forged - Shank Steel	16 bar	DN100/115mm	DN100	



Storz-Kupplung mit langem Stutzen mit Verriegelung (Saug/Druck)

DIN geschmiedet - mit NBR Dichtung

Storz coupling with serrated hose shank - (DIN) - NBR gasket

Raccord Storz à douille annelée - Joint NBR

Acople Storz con espiga para manguera (forjado) - Junta NBR

Złącze strażackie STORZ z długą karbowaną końcówką do węża (ssawno/tłoczna) - (DIN wykuty) - NBR Uszczelka

Raccordo Storz portagomma (DIN forgiato) - guarnizione in NBR

⁽¹⁾ langer Storz Stutzen

⁽¹⁾ long storz hose shank



⁽²⁾ mit Sicherungsbund

⁽²⁾ with collar

Part-No.	Material	WP	DN/KA	Shank	Price
ST75/75DINLST-H ⁽¹⁾	Aluminum forged	16 bar	DN75(B)/89mm	75mm	
ST75/75DINLST-SZH ⁽²⁾	Aluminum forged	16 bar	DN75(B)/89mm	75mm	

Vorhängeschloss für abschließbare Kupplungen

Padlock

Cadenas

Candado

Kłódka z

Lucchetto



Part-No.	Material	Description	Price
LOCKSS	Aluminum	Padlock in SS304 with keys	
LOCKSS2	SS304	Padlock in SS304 with keys (long bolt)	
LOCKBR	Brass	Padlock in brass with keys	



Storz-Kupplung mit BSP Innengewinde

DIN geschmiedet - mit NBR Dichtung

Storz coupling with female thread BSP - (DIN) - NBR gasket

Raccord Storz taraudé femelle BSP - Joint NBR

Acople Storz con rosca hembra BSP - (forjado) - Junta NBR

Złącze strażackie STORZ z gwintem wewnętrznym BSP (DIN wykuty) - NBR Uszczelka

Raccordo Storz filettato femmina BSP - (DIN forgiato) - Guarnizione NBR



Part-No.	Material	WP	DN/KA	Thread	Price
ST25IG075DIN	Aluminum forged	16 bar	DN25(D)/31mm	3/4"	
ST25IG100DIN	Aluminum forged	16 bar	DN25(D)/31mm	1"	
ST38IG100DIN	Aluminum forged	16 bar	DN38/51mm	1"	
ST38IG150DIN	Aluminum forged	16 bar	DN38/51mm	1 1/2"	
ST52IG125DIN	Aluminum forged	16 bar	DN52(C)/66mm	1 1/4"	
ST52IG150DIN	Aluminum forged	16 bar	DN52(C)/66mm	1 1/2"	
ST52IG200DIN	Aluminum forged	16 bar	DN52(C)/66mm	2"	
ST65IG250DIN	Aluminum forged	16 bar	DN65/81mm	2 1/2"	
ST75IG200DIN	Aluminum forged	16 bar	DN75(B)/89mm	2"	
ST75IG250DIN	Aluminum forged	16 bar	DN75(B)/89mm	2 1/2"	
ST75IG300DIN	Aluminum forged	16 bar	DN75(B)/89mm	3"	
ST110IG400DIN	Aluminum forged	16 bar	DN110(A)/133mm	4"	
ST125IG500DIN	Aluminum forged	16 bar	DN125/148mm	5"	
ST150IG600DIN	Aluminum forged	16 bar	DN150/160mm	6"	

NEW

Storz-Kupplung mit drehbarem BSP Innengewinde

DIN geschmiedet - mit NBR Dichtung

Storz coupling with swivel female thread BSP - (DIN) - NBR gasket

Raccord Storz rotatif taraudé femelle BSP- Joint NBR

Acople Storz giratorio, rosca hembra BSP - (forjado) - Junta NBR

Złącze strażackie Storz z gwintem obrotowy wewnętrznym BSP (DIN wykuty) - NBR Uszczelka

Raccordo Storz girevole, filettato BSP femmina - (DIN forgiato) - Guarnizione NBR



Part-No.	Material	WP	DN/KA	Thread	Price
ST52IG200DIN-SW	Aluminum forged	16 bar	DN52(C)/66mm	2"	
ST75IG300DIN-SW	Aluminum forged	16 bar	DN75(B)/89mm	3"	
ST110IG400DIN-SW	Aluminum forged	16 bar	DN110(A)/133mm	4"	





Storz-Kupplung mit BSP Außengewinde

DIN geschmiedet - mit NBR Dichtung

Storz coupling with male thread BSP - (DIN) - NBR gasket

Raccord Storz fileté mâle BSP - Joint NBR

Acople Storz con rosca macho BSP - (forjado) - Junta NBR

Złącze strażackie STORZ z gwintem zewnętrznym BSP (DIN wykuty) - NBR Uszczelka

Raccordo Storz filettato maschio BSP - (DIN forgiato) - Guarnizione NBR

Part-No.	Material	WP	DN/KA	Thread	Price
ST25AG075DIN	Aluminum forged	16 bar	DN25(D)/31mm	3/4"	
ST25AG100DIN	Aluminum forged	16 bar	DN25(D)/31mm	1"	
ST38AG150DIN	Aluminum forged	16 bar	DN38/51mm	1 1/2"	
ST52AG150DIN	Aluminum forged	16 bar	DN52(C)/66mm	1 1/2"	
ST52AG200DIN	Aluminum forged	16 bar	DN52(C)/66mm	2"	
ST65AG250DIN	Aluminum forged	16 bar	DN65/81mm	2 1/2"	
ST75AG250DIN	Aluminum forged	16 bar	DN75(B)/89mm	2 1/2"	
ST75AG300DIN	Aluminum forged	16 bar	DN75(B)/89mm	3"	
ST110AG400DIN	Aluminum forged	16 bar	DN110(A)/133mm	4"	
ST125AG500DIN	Aluminum forged	16 bar	DN125/148mm	5"	
ST150AG600DIN	Aluminum forged	16 bar	DN150/160mm	6"	



Storz-Kupplung mit drehbarem BSP Außengewinde

DIN geschmiedet - mit NBR Dichtung

Storz coupling with swivel male thread BSP - (DIN) - NBR gasket

Raccord Storz rotatif fileté mâle BSP- Joint NBR

Acople Storz giratorio, rosca macho BSP - (forjado) - Junta NBR

Złącze strażackie STORZ z gwintem obrotowy zewnętrznym BSP (DIN wykuty) - NBR Uszczelka

Raccordo Storz girevole, filettato BSP maschio - (DIN forgiato) - Guarnizione NBR

Part-No.	Material	WP	DN/KA	Thread	Price
ST52AG200DIN-SW	Aluminum forged	16 bar	DN52(C)/66mm	2"	
ST75AG300DIN-SW	Aluminum forged	16 bar	DN75(B)/89mm	3"	
ST110AG400DIN-SW	Aluminum forged	16 bar	DN110(A)/133mm	4"	



Storz-Blindkupplung mit Kette

DIN geschmiedet - mit NBR Dichtung

Storz cap with chain - (DIN) - NBR gasket

Bouchon Storz avec chaînette - Joint NBR

Tapón Storz con cadena - (forjado)- Junta NBR

Złącze strażackie STORZ zaślepka z łańcuszkiem (DIN wykuty) - NBR Uszczelka

Raccordo Storz. Tappo con catterna - (DIN forgiato) - Guarnizione NBR



Part-No.	Material	WP	DN/KA	Price
ST25DINBK	Aluminum forged	16 bar	DN25(D)/31mm	
ST38DINBK	Aluminum forged	16 bar	DN38/51mm	NEW
ST52DINBK	Aluminum forged	16 bar	DN52(C)/66mm	
ST65DINBK	Aluminum forged	16 bar	DN65/81mm	
ST75DINBK	Aluminum forged	16 bar	DN75(B)/89mm	
ST110DINBK	Aluminum forged	16 bar	DN110(A)/133mm	
ST125DINBK	Aluminum forged	16 bar	DN125/148mm	
ST150DINBK	Aluminum forged	16 bar	DN150/160mm	

Storz-Kupplung mit IBC Innengewinde

DIN geschmiedet - mit NBR Dichtung

Storz coupling - (DIN) with IBC female thread - NBR gasket

Raccord Storz taraudé IBC femelle - Joint NBR

Acople Storz (forjado) con rosca hembra IBC - Junta NBR

Złącze strażackie STORZ (DIN wykuty) z IBC gwintem wewnętrznym - NBR Uszczelka

Raccordo Storz (DIN forgiato) filettato IBC femmina - Guarnizione NBR



Part-No.	Material	WP	DN/KA	IBC	Price
ST52IBCF60DIN	Aluminum forged	16 bar	DN52(C)/66mm	S60x6	





Storz-Kupplung mit Reduzierung

DIN geschmiedet - mit NBR Dichtung

Storz reducer fixed - (DIN) - NBR gasket

Réduction Storz fixe - Joint NBR

Reducción Storz - (forjado) - Junta NBR

Złącze strażackie STORZ redukcja (DIN wykuty) - NBR Uszczelka

Riduzione raccordo Storz (Din forgiato) - Guarnizione NBR

Part-No.	Material	WP	DN/KA	DN/KA	Price
ST52/25DINRED	Aluminum forged	16 bar	DN52(C)/66mm	DN25(D)/31mm	
ST75/52DINRED	Aluminum forged	16 bar	DN75(B)/89mm	DN52(C)/66mm	
ST75/65DINRED	Aluminum forged	16 bar	DN75(B)/89mm	DN65/81mm	
ST110/75DINRED	Aluminum forged	16 bar	DN110(A)/133mm	DN75(B)/89mm	



Storz-Kupplung mit langem Stutzen (Saug/Druck)

Industrie-Ausführung - gegossen - mit NBR Dichtung

Storz coupling with serrated hose shank - (industrial) - NBR gasket

Raccord Storz à douille annelée - Joint NBR

Acople Storz con espiga para manguera (fundido) - Junta NBR

Złącze strażackie STORZ z długą karbowaną końcówką do węża (ssawno/tłoczna) - (wykonanie przemysłowe - odlewane) - NBR Uszczelka

Raccordo Storz portagomma - Guarnizione NBR



Part-No.	Material	WP	DN/KA	Shank	Price
ST25/25LST	Aluminum cast	10 bar	DN25(D)/31mm	DN25	
ST38/38LST	Aluminum cast	10 bar	DN38/51mm	DN38	
ST45/45LST	Aluminum cast	10 bar	DN45/59mm	DN45	
ST52/32LST	Aluminum cast	10 bar	DN52(C)/66mm	DN21	
ST52/38LST	Aluminum cast	10 bar	DN52(C)/66mm	DN38	
ST52/45LST	Aluminum cast	10 bar	DN52(C)/66mm	DN45	
ST52/52LST	Aluminum cast	10 bar	DN52(C)/66mm	DN52	
ST65/25LST	Aluminum cast	10 bar	DN65/81mm	DN25	
ST65/32LST	Aluminum cast	10 bar	DN65/81mm	DN32	
ST65/38LST	Aluminum cast	10 bar	DN65/81mm	DN38	
ST65/52LST	Aluminum cast	10 bar	DN65/81mm	DN52	
ST65/65LST	Aluminum cast	10 bar	DN65/81mm	DN65	
ST75/75LST	Aluminum cast	10 bar	DN75(B)/89mm	DN75	
ST100/100LST	Aluminum cast	10 bar	DN100/115mm	DN100	
ST110/100LST	Aluminum cast	10 bar	DN110(A)/133mm	DN100	





Storz-Kupplung mit BSP Innengewinde

Industrie-Ausführung - gegossen - mit NBR Dichtung

Storz coupling with female thread BSP - (industrial) - NBR gasket

Raccord Storz taraudé femelle BSP - Joint NBR

Acople Storz rosca hembra BSP - (fundido) - Junta NBR

Złącze strażackie STORZ z gwintem wewnętrznym BSP (wykonanie przemysłowe - odlewane) - NBR Uszczelka

Raccordo Storz, filettato femmina BSP - Guarnizione NBR

Part-No.	Material	WP	DN/KA	Thread	Price
ST25IG075	Aluminum cast	10 bar	DN25(D)/31mm	3/4"	
ST25IG100	Aluminum cast	10 bar	DN25(D)/31mm	1"	
ST38IG150	Aluminum cast	10 bar	DN38/51mm	1 1/2"	
ST45IG150	Aluminum cast	10 bar	DN45/59mm	1 1/2"	
ST45IG200	Aluminum cast	10 bar	DN38/51mm	2"	
ST52IG100	Aluminum cast	10 bar	DN52(C)/66mm	1"	
ST52IG125	Aluminum cast	10 bar	DN52(C)/66mm	1 1/4"	
ST52IG150	Aluminum cast	10 bar	DN52(C)/66mm	1 1/2"	
ST52IG200	Aluminum cast	10 bar	DN52(C)/66mm	2"	
ST52IG250	Aluminum cast	10 bar	DN52(C)/66mm	2 1/2"	
ST65IG250	Aluminum cast	10 bar	DN65/81mm	2 1/2"	
ST75IG200	Aluminum cast	10 bar	DN75(B)/89mm	2"	
ST75IG250	Aluminum cast	10 bar	DN75(B)/89mm	2 1/2"	
ST75IG300	Aluminum cast	10 bar	DN75(B)/89mm	3"	
ST110IG400	Aluminum cast	10 bar	DN110(A)/133mm	4"	



Storz-Kupplung mit BSP Außengewinde

Industrie-Ausführung - gegossen - mit NBR Dichtung

Storz coupling with male thread BSP - (industrial) - NBR gasket

Raccord Storz fileté mâle BSP - Joint NBR

Acople Storz rosca macho BSP - (fundido) - Junta NBR

Złącze strażackie STORZ z gwintem zewnętrznym BSP (wykonanie przemysłowe - odlewane) - NBR Uszczelka

Raccordo Storz filettato maschio BSP - Guarnizione NBR



Part-No.	Material	WP	DN/KA	Thread	Price
ST25AG075	Aluminum cast	10 bar	DN25(D)/31mm	3/4"	
ST25AG100	Aluminum cast	10 bar	DN25(D)/31mm	1"	
ST38AG150	Aluminum cast	10 bar	DN38/51mm	1 1/2"	
ST45AG150	Aluminum cast	10 bar	DN45/59mm	1 1/2"	
ST45AG200	Aluminum cast	10 bar	DN38/51mm	2"	
ST52AG100	Aluminum cast	10 bar	DN52(C)/66mm	1"	
ST52AG125	Aluminum cast	10 bar	DN52(C)/66mm	1 1/4"	
ST52AG150	Aluminum cast	10 bar	DN52(C)/66mm	1 1/2"	
ST52AG200	Aluminum cast	10 bar	DN52(C)/66mm	2"	
ST52AG250	Aluminum cast	10 bar	DN52(C)/66mm	2 1/2"	
ST65AG250	Aluminum cast	10 bar	DN65/81mm	2 1/2"	
ST75AG200	Aluminum cast	10 bar	DN75(B)/89mm	2"	
ST75AG250	Aluminum cast	10 bar	DN75(B)/89mm	2 1/2"	
ST75AG300	Aluminum cast	10 bar	DN75(B)/89mm	3"	
ST110AG400	Aluminum cast	10 bar	DN110(A)/133mm	4"	





Storz-Blindkupplung mit Kette

Industrie-Ausführung - gegossen - mit NBR Dichtung

Storz cap with chain - (industrial) - NBR gasket

Bouchon Storz avec chaînette - Joint NBR

Tapón Storz con cadena - (fundido) - Junta NBR

Złącze strażackie STORZ zaślepka z łańcuszkiem (wykonanie przemysłowe - odlewane) - NBR Uszczelka

Tappo storz con catterna - Guarnizione NBR

Part-No.	Material	WP	DN/KA	Price
ST25BK	Aluminum cast	10 bar	DN25(D)/31mm	
ST38BK	Aluminum cast	10 bar	DN38/51mm	
ST45BK	Aluminum cast	10 bar	DN45/59mm	
ST52BK	Aluminum cast	10 bar	DN52(C)/66mm	
ST65BK	Aluminum cast	10 bar	DN65/81mm	
ST75BK	Aluminum cast	10 bar	DN75(B)/89mm	
ST110BK	Aluminum cast	10 bar	DN110(A)/133mm	



Storz-Kupplung mit Reduzierung

Industrie-Ausführung - gegossen - mit NBR Dichtung

Storz reducer fixed - (industrial) - NBR gasket

Réduction Storz fixe - Joint NBR

Reducción Storz - (fundido)- Junta NBR

Złącze strażackie STORZ redukcja (wykonanie przemysłowe - odlewane) - NBR Uszczelka

Riduzione Storz - Guarnizione NBR

Part-No.	Material	WP	DN/KA	DN/KA	Price
ST52/25RED	Aluminum cast	10 bar	DN52(C)/66mm	DN25(D)/31mm	
ST75/52RED	Aluminum cast	10 bar	DN75(B)/89mm	DN52(C)/66mm	
ST110/75RED	Aluminum cast	10 bar	DN110(A)/133mm	DN75(B)/89mm	



Storz-Kupplung mit langem Stutzen (Saug/Druck) mit Verriegelung

Industrie-Ausführung - gegossen - mit NBR Dichtung

Storz coupling with serrated hose shank with security lock - (industrial) - NBR gasket

Raccord Storz à douille annelée - Type Autolock - Joint NBR

Acople Storz fundido con espiga para manguera con cierre de seguridad - Autolock - Junta NBR

Złącze strażackie STORZ z długą karbowaną końcówką do węża (ssawno/tłoczna) z rączkami zabezpieczającymi - (wykonanie przemysłowe - odlewane) - NBR Uszczelka

Raccordo Storz portagomma - Autolock - Guarnizione NBR



Part-No.	Material	WP	DN/KA	Shank	Price
ST52/52LST-SL	Aluminum cast	10 bar	DN52(C)/66mm	DN52	
ST75/75LST-SL	Aluminum cast	10 bar	DN75(B)/89mm	DN75	
ST110/100LST-SL	Aluminum cast	10 bar	DN110(A)/133mm	DN100	

Storz-Kupplung mit BSP Innengewinde mit Verriegelung

Industrie-Ausführung - gegossen - mit NBR Dichtung

Storz coupling with female thread BSP with security lock - (industrial) - NBR gasket

Raccord Storz taraudé femelle BSP - Type Autolock - Joint NBR

Acople Storz fundido rosca hembra BSP con cierre de seguridad - Autolock - Junta NBR

Złącze strażackie STORZ z gwintem wewnętrznym BSP z rączkami zabezpieczającymi (wykonanie przemysłowe - odlewane) - NBR Uszczelka

Raccordo Storz, filettato femmina BSP - Autolock - Guarnizione NBR



Part-No.	Material	WP	DN/KA	Thread	Price
ST52IG200-SL	Aluminum cast	10 bar	DN52(C)/66mm	2"	
ST75IG300-SL	Aluminum cast	10 bar	DN75(B)/89mm	3"	
ST110IG400-SL	Aluminum cast	10 bar	DN110(A)/133mm	4"	





Storz-Blindkupplung mit Kette

Industrie-Ausführung - gegossen - mit NBR Dichtung

Storz cap with chain - (industrial) - NBR gasket

Bouchon Storz avec chaînette - Joint NBR

Tapón Storz fundido con cadena y cierre de seguridad - Autolock - Junta NBR

Złącze strażackie STORZ zaślepka z łańcuszkiem (wykonanie przemysłowe - odlewane) - NBR Uszczelka

Raccordo Storz. Tappo con catterna - Autolock - Guarnizione NBR

Part-No.	Material	WP	DN/KA	Price
ST52BK-SL	Aluminum cast	10 bar	DN52(C)/66mm	
ST75BK-SL	Aluminum cast	10 bar	DN75(B)/89mm	
ST110BK-SL	Aluminum cast	10 bar	DN110(A)/133mm	



90° Bogen AG/AG BSPP flachdichtend

90° Elbow male BSPP thread - flat sealing

Coude 90° filetage mâle BSPP - Joint plat

90° Machón doble BSPP

90° Lolanoz gwintami zewnętrznymi cylindrycznymi

Curva 90° maschio - maschio BSP

Part-No.	Material	WP	Thread	Thread	Price
MMA2020FL-90	Aluminum	10 bar	2"	2"	
MMA3030FL-90	Aluminum	10 bar	3"	3"	
MMA4040FL-90	Aluminum	10 bar	4"	4"	



Reduzierung IG/IG - mit kurzem Gewinde

Reduction female BSPP thread - with short thread

Réduction double femelle/femelle - avec filetage court

Reducción rosca hembra BSPP - con rosca corta

Redukcja z gwintami - z krótkim gwintem

Riduzione filettato femmina BSPP - con filo corto



Part-No.	Material	WP	Thread	Thread	Price
FFA2015	Aluminum	16 bar	2"	1 1/2"	
FFA2515	Aluminum	16 bar	2 1/2"	1 1/2"	
FFA2520	Aluminum	16 bar	2 1/2"	2"	
FFA3015	Aluminum	16 bar	3"	1 1/2"	
FFA3020	Aluminum	16 bar	3"	2"	
FFA3025	Aluminum	16 bar	3"	2 1/2"	
FFA4015	Aluminum	16 bar	4"	1 1/2"	
FFA4020	Aluminum	16 bar	4"	2"	
FFA4025	Aluminum	16 bar	4"	2 1/2"	
FFA4030	Aluminum	16 bar	4"	3"	





Storz-Kupplung mit langem Stutzen (Saug/Druck)

mit FKM Dichtung

Storz coupling with serrated hose shank - FKM gasket

Raccord Storz à douille annelée - Joint FKM

Acople Storz con espiga para manguera - Junta FKM

Złącze strażackie STORZ z długą karbowaną końcówką do węża (ssawno/tłoczna) - FKM Uszczelka

Raccordo Storz portagomma - Guarnizione FKM

Part-No.	Material	WP	DN/KA	Shank	Price
ST25/25LTSS	SS 1.4581	16 bar	DN25(D)/31mm	DN25	
ST52/52LTSS	SS 1.4581	16 bar	DN52(C)/66mm	DN52	
ST75/75LTSS	SS 1.4581	16 bar	DN75(B)/89mm	DN75	
NEW ST110/100LTSS	SS 1.4581	16 bar	DN110(A)/133mm	DN100	



Storz-Kupplung mit Sägezahnprofilstutzen für Klemmschaleneinband

mit FKM Dichtung

Storz coupling with serrated hose shank for safety clamps - FKM gasket

Raccord Storz à douille annelée - Joint FKM

Acople Storz con espiga dentada para abrazaderas de seguridad - Junta FKM

Złącze strażackie STORZ z karbowaną końcówką do węża pod obejmę skorupową - FKM Uszczelka

Raccordo Storz portagomma - Guarnizione FKM

Part-No.	Material	WP	DN/KA	Shank	Price
ST52/52LTSS-SZ	SS 1.4581	16 bar	DN52(C)/66mm	DN50	
ST75/75LTSS-SZ	SS 1.4581	16 bar	DN75(B)/89mm	DN75	
NEW ST110/100LTSS-SZ	SS 1.4581	16 bar	DN110(A)/133mm	DN100	



Storz-Kupplung mit BSP Innengewinde mit FKM Dichtung

Storz coupling with female thread BSP - FKM gasket

Raccord Storz taraudé femelle BSP - Joint FKM

Acople Storz con rosca hembra BSP - Junta FKM

Złącze strażackie STORZ z gwintem wewnętrznym BSP - FKM Uszczelka

Raccordo Storz, filettato femmina BSP - Guarnizione FKM



Part-No.	Material	WP	DN/KA	Thread	Price
ST25IG100SS	SS 1.4581	16 bar	DN25(D)/31mm	1"	
ST52IG200SS	SS 1.4581	16 bar	DN52(C)/66mm	2"	
ST65IG250SS	SS 1.4581	16 bar	DN65/81mm	2 1/2"	
ST75IG300SS	SS 1.4581	16 bar	DN75(B)/89mm	3"	
ST110IG400SS	SS 1.4581	16 bar	DN110/133mm	4"	

NEW

Storz-Kupplung mit BSP Außengewinde mit FKM Dichtung

Storz coupling with male thread BSP - FKM gasket

Raccord Storz fileté mâle BSP - Joint FKM

Acople Storz con rosca macho BSP - Junta FKM

Złącze strażackie STORZ z gwintem zewnętrznym BSP (wykonanie przemysłowe - odlewane) - FKM Uszczelka

Raccordo Storz filettato maschio BSP - Guarnizione FKM



Part-No.	Material	WP	DN/KA	Thread	Price
ST25AG100SS	SS 1.4581	16 bar	DN25(D)/31mm	1"	
ST52AG200SS	SS 1.4581	16 bar	DN52(C)/66mm	2"	
ST75AG300SS	SS 1.4581	16 bar	DN75(B)/89mm	3"	
ST110AG400SS	SS 1.4581	16 bar	DN110/133mm	4"	

NEW





Storz-Blindkupplung mit Kette mit FKM Dichtung

Storz cap with chain - FKM gasket
 Bouchon Storz avec chaînette - Joint FKM
 Tapón Storz con cadena - Junta FKM
 Złącze strażackie STORZ zaślepka z łańcuszkiem - FKM Uszczelka
 Raccordo Storz. Tappo con catterna - Guarnizione FKM

NEW

Part-No.	Material	WP	DN/KA	Price
ST25BKSS	SS 1.4581	16 bar	DN25(D)/31mm	
ST52BKSS	SS 1.4581	16 bar	DN52(C)/66mm	
ST75BKSS	SS 1.4581	16 bar	DN75(B)/89mm	
ST110BKSS	SS 1.4581	16 bar	DN110/133mm	



90° Bogen AG/AG BSPP flachdichtend

90° Elbow male BSPP thread - flat sealing
 90° Coude mâle/mâle à joint plat
 Codo 90° RM-RM BSPP
 90° Lolanoz gwintami zewnętrznymi cylindrycznymi
 Curva 90° maschio - maschio BSPP

Part-No.	Material	WP	Thread	Thread	Price
MMS075075FL-90	SS 316	16 bar	3/4"	3/4"	
MMS1010FL-90	SS 316	16 bar	1"	1"	
MMS1212FL-90	SS 316	16 bar	1 1/4"	1 1/4"	
MMS1515FL-90	SS 316	16 bar	1 1/2"	1 1/2"	
MMS2020FL-90	SS 316	16 bar	2"	2"	
MMS3030FL-90	SS 316	16 bar	3"	3"	
MMS4040FL-90	SS 316	16 bar	4"	4"	



Storz-Kupplung mit langem Stutzen (Saug/Druck)

mit NBR Dichtung

Storz coupling with serrated hose shank - NBR gasket

Raccord Storz à douille annelée - Joint NBR

Acople Storz con espiga para manguera - Junta NBR

Złącze strażackie STORZ z długą karbowaną końcówką do węża (ssawno/tłoczna) - NBR Uszczelka

Raccordo Storz portagomma - Guarnizione NBR



Part-No.	Material	WP	DN/KA	Shank	Price
ST52/52LSTBR	Brass	16 bar	DN52(C)/66mm	DN52	
ST75/75LSTBR	Brass	16 bar	DN75(B)/89mm	DN75	

Storz-Kupplung mit BSP Innengewinde

mit NBR Dichtung

Storz coupling with female thread BSP - NBR gasket

Raccord Storz taraudé femelle BSP - Joint NBR

Acople Storz con rosca hembra BSP - Junta NBR

Złącze strażackie STORZ z gwintem wewnętrznym BSP - NBR Uszczelka

Raccordo Storz, filettato femmina BSP - Guarnizione NBR



Part-No.	Material	WP	DN/KA	Thread	Price
ST52IG200BR	Brass	16 bar	DN52(C)/66mm	2"	
ST75IG300BR	Brass	16 bar	DN75(B)/89mm	3"	

Storz-Kupplung mit BSP Außengewinde

mit NBR Dichtung

Storz coupling with male thread BSP - NBR gasket

Raccord Storz fileté mâle BSP - Joint NBR

Acople Storz con rosca macho BSP - Junta NBR

Złącze strażackie STORZ z gwintem zewnętrznym BSP - NBR Uszczelka

Raccordo Storz filettato maschio BSP - Guarnizione NBR



Part-No.	Material	WP	DN/KA	Thread	Price
ST52AG200BR	Brass	16 bar	DN52(C)/66mm	2"	
ST75AG300BR	Brass	16 bar	DN75(B)/89mm	3"	





Storz-Blindkupplung mit Kette
mit NBR Dichtung

Storz cap with chain - NBR gasket
 Bouchon Storz avec chaînette - Joint NBR
 Tapón Storz con cadena - Junta NBR
 Złącze strażackie STORZ zaślepka z łańcuszkiem - NBR Uszczelka
 Raccordo Storz. Tappo con catterna - Guarnizione NBR

Part-No.	Material	WP	DN/KA	Price
ST52BKBR	Brass	16 bar	DN52(C)/66mm	
ST75BKBR	Brass	16 bar	DN75(B)/89mm	



C-N Strahlrohr mit Storz C-Kupplung

Strahlrohr mit 2" Storz C-Kupplung, Rohrstück, Düse und Mundstück aus Polyamid.
 Mundstückbohrung 9mm, Gesamtlänge 410mm. Ähnlich zu DIN14365

C-Branchpipe
 Double position Branchpipe Jet / Spray with Storz couplings 2" 9mm/410AL/Poly Red
 C-Branchpipe
 Double position Branchpipe Jet / arroseur avec Storz couplings 2" 9mm/410AL/Poly Red
 Lanza alemana 3 efectos con acople Storz
 Lanza alemana de doble posición/ rociador con acople Storz de 2" 9mm/410AL /Poliéster Rojo
 Rura stalowa 52-C złącze STORZ
 Rura stalowa z 2" Złącze Storz 52-C, Rura, dysza i ustnik wykonane z poliamidu. Dysza 9 mm, całkowita długość 410 mm
 Lancia tedesca 3 effetti con accoppiamento Storz
 Lancia / spruzzatore tedesco doppia posizione con innesto Storz da 2" 9mm / 410AL / poliestere rosso

Part-No.	Colour	DN/KA	Price
ST52STRAHLROHR	Red	DN52(C)/66mm	



Storz Spannschlüssel

Storz spanner

Clé Storz

Llave fija para Storz

STORZ Klucz montażowy

Chiave fissa per Storz

Part-No.	Material	Size	Price
SS	Steel with plastic handle	A/B/C	
SS3	Steel	B/C	

**Schauglas mit beidseitigem BSPP Außengewinde, Material PC**

Sight glass with both sides BSPP male thread, polycarbonate

Tube transparent Filetage mâle BSPP des deux côtés, polycarbonate

Mirilla con rosca macho BSPP en ambos lados, material PC

Tubo trasparente rosca macho BSPP en ambos lados, policarbonato

Tubo trasparente con filetto maschio BSPP su entrambi i lati, policarbonato



Part-No.	Material	WP	Thread	Thread	Length	Price
SGBSPM200	Polycarbonate	10 bar	2"	2"	200mm	
SGBSPM300	Polycarbonate	10 bar	3"	3"	200mm	
SGBSPM400	Polycarbonate	10 bar	4"	4"	200mm	



INFORMATIONEN

Klauenkupplungen



Klauenkupplungen gibt es in den verschiedensten Ausführungen. Wesentlich sind hier die Klauenabstände. Während die 40mm Variante oftmals für Wasser verwendet wird, findet die 42mm Ausführung ihre Verwendung in Pressluft Applikationen.

Die 42mm Version ist in der DIN 3489 genormt und für Gasanwendungen vorgesehen. Sie ist unter dem Namen EUROPEAN Type oder Kompressor-Kupplung bekannt.

Auffällig ist die stark herausstehende Dichtung, die beim Kuppeln zusammengedrückt wird. Eine weitere Variante ist die Expresskupplung, die nicht mit der DIN 3489 kompatibel ist.

WARUM MCC?

- Alle Varianten der o.g. Klauenkupplungssystemen ab Lager
- Qualitativ hochwertige Armaturen durch Verwendung von feinkörnigen Werkstoffen
- Verschiedenste Schlauchanschlussysteme und Schlauchklemmen verfügbar
- 42mm Klauenkupplung mit Sicherung (Typ „Mody“) erhältlich
- ISO228 und NPT-Gewinde verfügbar
- Hochwertige ölbeständige NBR-Dichtungen und säurebeständige FKM-Dichtungen auf Lager

TECHNISCHE INFORMATIONEN

- Norm: DIN 3489
- Gewinde: ISO 228 oder NPT im Gewinde dichtend
- Betriebsdruck: abhängig vom verwendeten Schlauch
- Armaturenwerkstoffe: Stahl verzinkt, Messing, Edelstahl
- Kupplungsdichtung: NBR, FKM

EINSATZGEBIET

Pressluft im Baugewerbe, Versorgungsstrecken, lose verlegte Betriebsmittelleitungen, Kompressor Stationen

EUROPEAN TYPE

42mm Knaggenabstand



US AUSFÜHRUNG

41mm Knaggenabstand



TYPE EXPRESS

42mm Knaggenabstand





INFORMATION

Claw Couplings

Claw couplings are available in a wide variety of designs. The claw distance is important here. While the 40 mm version is often used for water, the 42 mm version is used in compressed air applications.

The 42mm version is standardized in DIN 3489 and is intended for gas applications. It is known as the EUROPEAN type or compressor coupling.

A striking feature is the protruding gasket, which is compressed during coupling. Another variant is the express coupling, which is not compatible with DIN 3489.

WHY MCC?

- All versions of the above-mentioned claw coupling systems on stock
- High-quality fittings thanks to the use of fine-grained materials
- Various hose connection systems and hose clamps available
- 42mm claw coupling with fuse (type "Mody") available
- ISO228 and NPT threads available
- High-quality oil-resistant NBR gasket and acid-resistant FKM gaskets in stock



TECHNICAL INFORMATION

- Norm: DIN 3489
- Thead: ISO 228 or NPT thread-sealing
- Working pressure: depending on the hose used
- Material: galvanized steel, brass, stainless steel
- Gasket for coupling: NBR, FKM

AREA OF APPLICATION

This type of couplings are used in the construction sector and compressor hoses

EUROPEAN TYP

42mm claw distance



TYP EXPRESS

42mm claw distance



US AUSFÜHRUNG

41mm claw distance





Klauenkupplung «EUROPEAN Type» Stutzen mit Sicherungsbund mit NBR Dichtung

Claw coupling EUROPEAN type, hose shank with collar - NBR gasket
 Raccord type européen à douille annelée - Joint NBR
 Racor tipo Europeo - Espiga con cuello de seguridad - Junta NBR
 Złącze kłowe «Typ Europejski» z karbowaną końcówką do węża z wiązką zabezpieczającą - NBR Uszczelka
 Raccordo tipo Europeo Portagomma e collare di sicurezza - Guarnizione NBR

*ohne Sicherungsbund
 * without collar

Part-No.	Material	WP	Claw Distance	Shank	Price
C038HE*	Steel	10 bar	42mm	11,5mm	
C050HE	Steel	10 bar	42mm	14,5mm	
C075HE	Steel	10 bar	42mm	20,5mm	
C100HE	Steel	10 bar	42mm	26,5mm	



Klauenkupplung «EUROPEAN Type» mit Außengewinde mit NBR Dichtung

Claw coupling EUROPEAN type, with male thread - NBR gasket
 Raccord type européen fileté mâle - Joint NBR
 Racor tipo Europeo con rosca macho - Junta NBR
 Złącze kłowe «Typ Europejski» z gwintem zewnętrznym - NBR Uszczelka
 Raccordo tipo Europeo filetto maschio - Guarnizione NBR

Part-No.	Material	WP	Claw Distance	Thread	Price
C038M	Steel	10 bar	42mm	3/8"	
C050M	Steel	10 bar	42mm	1/2"	
C075M	Steel	10 bar	42mm	3/4"	
C100M	Steel	10 bar	42mm	1"	



Klauenkupplung «EUROPEAN Type» mit Innengewinde mit NBR Dichtung

Claw coupling EUROPEAN type, with female thread - NBR gasket

Raccord type européen taraudé femelle - Joint NBR

Racor tipo Europeo con rosca hembra - Junta NBR

Złącze kłowe «Typ Europejski» z gwintem wewnętrznym - NBR Uszczelka

Raccordo tipo Europeo con filetto femmina - Guarnizione NBR



Part-No.	Material	WP	Claw Distance	Thread	Price
C038F	Steel	10 bar	42mm	3/8"	
C050F	Steel	10 bar	42mm	1/2"	
C075F	Steel	10 bar	42mm	3/4"	
C100F	Steel	10 bar	42mm	1"	





Klauenkupplung «EUROPEAN Type» Stutzen mit Sicherungsbund

mit Bohrung für Sicherungsclip - mit NBR Dichtung

Claw coupling EUROPEAN type, hose shank with collar - with bore for safety clip - NBR gasket

Raccord type européen à douille annelée - avec alésage pour clip de sécurité - Joint NBR

Racor tipo Europeo Espiga con collar - con orificio para el clip de seguridad - Junta NBR

Złącze kłowe «Typ Europejski» z karbowaną końcówką do węża z wiązką zabezpieczającą - z otworem na zacisk bezpieczeństwa - NBR Uszczelka

Raccordo tipo Europeo Portagomma e collare di sicurezza - con foro per clip di sicurezza - Guarnizione NBR

Part-No.	Material	WP	Claw Distance	Shank	Price
C050HE-P	Steel	10 bar	42mm	14,5mm	
C075HE-P	Steel	10 bar	42mm	20,5mm	
C100HE-P	Steel	10 bar	42mm	26,5mm	



Klauenkupplung «EUROPEAN Type» mit Außengewinde

mit Bohrung für Sicherungsclip mit NBR Dichtung

Claw coupling EUROPEAN type, with male thread - with bore for safety clip - NBR gasket

Raccord type européen fileté mâle - avec alésage pour clip de sécurité - Joint NBR

Racor tipo Europeo con rosca macho - con orificio para el clip de seguridad - Junta NBR

Złącze kłowe «Typ Europejski» z gwintem zewnętrznym - z otworem na zacisk bezpieczeństwa - NBR Uszczelka

Raccordo tipo Europeo filetto maschio - con foro per clip di sicurezza - Guarnizione NBR

Part-No.	Material	WP	Claw Distance	Thread	Price
C050M-P	Steel	10 bar	42mm	1/2"	
C075M-P	Steel	10 bar	42mm	3/4"	
C100M-P	Steel	10 bar	42mm	1"	



Klauenkupplung «EUROPEAN Type» mit Innengewinde

mit Bohrung für Sicherungsclip mit NBR Dichtung



Claw coupling EUROPEAN type, with female thread - with bore for safety clip - NBR gasket

Raccord type européen taraudé femelle - avec alésage pour clip de sécurité - Joint NBR

Racor tipo Europeo «EA DIN3489 » con rosca hembra - con orificio para el clip de seguridad - Junta NBR

Złącze kłowe «Typ Europejski» z gwintem wewnętrznym - z otworem na zacisk bezpieczeństwa - NBR Uszczelka

Raccordo tipo Europeo filetto femmina - con foro per clip di sicurezza - Guarnizione NBR

Part-No.	Material	WP	Claw Distance	Thread	Price
C050F-P	Steel	10 bar	42mm	1/2"	
C075F-P	Steel	10 bar	42mm	3/4"	
C100F-P	Steel	10 bar	42mm	1"	

Klauenkupplung «EUROPEAN Type» Blindkappe

mit Bohrung für Sicherungsclip mit NBR Dichtung



Claw coupling EUROPEAN type, dust cap - with bore for safety clip - NBR gasket

Raccord type européen avec alésage pour clip de sécurité - Joint NBR

Tapón tipo Europeo - con orificio para el clip de seguridad - Junta NBR

Złącze kłowe zaślepiające «Typ Europejski» - z otworem na zacisk bezpieczeństwa - NBR Uszczelka

Tappo tipo Europeo - con foro per clip di sicurezza - Guarnizione NBR

NEW

Part-No.	Material	WP	Claw Distance	Price
CCAP-P	Steel	10 bar	42mm	

Zubehör

Accessories

Accessoires

Accesorios

Akcesoria

Accessori



Part-No.	Description	Material	DN	Price
CPIN-SS-P	Pin for Couplings (-P)	SS 304	Universal	





Klauenkupplung «EUROPEAN Type» Stutzen mit Sicherungsbund mit NBR Dichtung

Claw coupling EUROPEAN type, hose shank with collar - NBR gasket

Raccord type européen à douille annelée - Joint NBR

Racor tipo Europeo «EA DIN3489» Espiga con cuello de seguridad - Junta NBR

Złącze kłowe «Typ Europejski» z karbowaną końcówką do węża z wiązką zabezpieczającą - NBR Uszczelka

Raccordo tipo Europeo Portagomma e collare di sicurezza - Guarnizione NBR

Part-No.	Material	WP	Claw Distance	Shank	Price
C050HE-SS	SS 316	10 bar	42mm	14,5mm	
C075HE-SS	SS 316	10 bar	42mm	20,5mm	
C100HE-SS	SS 316	10 bar	42mm	26,5mm	



Klauenkupplung «EUROPEAN Type» mit Außengewinde mit NBR Dichtung

Claw coupling EUROPEAN type, with male thread - NBR gasket

Raccord type européen fileté mâle - Joint NBR

Racor tipo Europeo con rosca macho - Junta NBR

Złącze kłowe «Typ Europejski» z gwintem zewnętrznym - NBR Uszczelka

Raccordo tipo Europeo filetto maschio - Guarnizione NBR

Part-No.	Material	WP	Claw Distance	Thread	Price
C050M-SS	SS 316	10 bar	42mm	1/2"	
C075M-SS	SS 316	10 bar	42mm	3/4"	
C100M-SS	SS 316	10 bar	42mm	1"	



Klauenkupplung «EUROPEAN Type» mit Innengewinde mit NBR Dichtung

Claw coupling EUROPEAN type, with female thread - NBR gasket

Raccord type européen taraudé femelle - Joint NBR

Racor tipo Europeo con rosca hembra - Junta NBR

Złącze kłowe «Typ Europejski» z gwintem wewnętrznym - NBR Uszczelka

Raccordo tipo Europeo con filetto femmina - Guarnizione NBR



Part-No.	Material	WP	Claw Distance	Thread	Price
C050F-SS	SS 316	10 bar	42mm	1/2"	
C075F-SS	SS 316	10 bar	42mm	3/4"	
C100F-SS	SS 316	10 bar	42mm	1"	

Klauenkupplung «EUROPEAN Type» Blindkappe mit NBR Dichtung

Claw coupling EUROPEAN type, dust cap - NBR gasket

Raccord type européen - Joint NBR

Tapón tipo Europeo - Junta NBR

Złącze kłowe zaślepiające «Typ Europejski» - NBR Uszczelka

Tappo tipo Europeo - Guarnizione NBR



Part-No.	Material	WP	Claw Distance	Price
CCAP-SS	SS 316	10 bar	42mm	





Klauenkupplung «EUROPEAN Type» Stutzen mit Sicherungsbund mit Bohrung für Sicherungsclip mit NBR Dichtung

Claw coupling EUROPEAN type, hose shank with collar - with bore for safety clip - NBR gasket
 Raccord type européen à douille annelée - avec alésage pour clip de sécurité - Joint NBR
 Racor tipo Europeo - Espiga con cuelllo de seguridad - orificio para el clip de seguridad - Junta NBR
 Złącze kłowe «Typ Europejski» z karbowaną końcówką do węża z wiązką zabezpieczającą - z otworem na zacisk bezpieczeństwa - NBR Uszczelka
 Raccordo tipo Europeo - Portagomma e collare di sicurezza - con foro per clip di sicurezza - Guarnizione NBR

Part-No.	Material	WP	Claw Distance	Shank	Price
C050HE-SS-P	SS 316	10 bar	42mm	14,5mm	
C075HE-SS-P	SS 316	10 bar	42mm	20,5mm	
C100HE-SS-P	SS 316	10 bar	42mm	26,5mm	



Klauenkupplung «EUROPEAN Type» mit Außengewinde mit Bohrung für Sicherungsclip mit NBR Dichtung

Claw coupling EUROPEAN type, with male thread - with bore for safety clip - NBR gasket
 Raccord type européen taraudé femelle - avec alésage pour clip de sécurité - Joint NBR
 Racor tipo Europeo con rosca macho - con orificio para el clip de seguridad - Junta NBR
 Złącze kłowe «Typ Europejski» z gwintem zewnętrznym - z otworem na zacisk bezpieczeństwa - NBR Uszczelka
 Raccordo tipo Europeo filetto maschio - con foro per clip di sicurezza - Guarnizione NBR

Part-No.	Material	WP	Claw Distance	Thread	Price
C050M-SS-P	SS 316	10 bar	42mm	1/2"	
C075M-SS-P	SS 316	10 bar	42mm	3/4"	
C100M-SS-P	SS 316	10 bar	42mm	1"	



Klauenkupplung «EUROPEAN Type» mit Innengewinde

mit Bohrung für Sicherungsclip mit NBR Dichtung

Claw coupling EUROPEAN type, with female thread - with bore for safety clip - NBR gasket

Raccord type européen taraudé femelle - avec alésage pour clip de sécurité - Joint NBR

Racor tipo Europeo «EA DIN3489 » con rosca hembra - con orificio para el clip de seguridad - Junta NBR

Złącze kłowe «Typ Europejski» z gwintem wewnętrznym - z otworem na zacisk bezpieczeństwa - NBR Uszczelka

Raccordo tipo Europeo filetto femmina - con foro per clip di sicurezza - Guarnizione NBR



Part-No.	Material	WP	Claw Distance	Thread	Price
C050F-SS-P	SS 316	10 bar	42mm	1/2"	
C075F-SS-P	SS 316	10 bar	42mm	3/4"	
C100F-SS-P	SS 316	10 bar	42mm	1"	

Klauenkupplung «EUROPEAN Type» Blindkappe

mit Bohrung für Sicherungsclip mit NBR Dichtung

Claw coupling EUROPEAN type, dust cap - with bore for safety clip - NBR gasket

Raccord type européen avec alésage pour clip de sécurité - Joint NBR

Racor tipo Europeo - con orificio para el clip de seguridad - Junta NBR

Złącze kłowe zaślepiające «Typ Europejski» - z otworem na zacisk bezpieczeństwa - NBR Uszczelka

Raccordo tipo Europeo con foro per clip di sicurezza - Guarnizione NBR



Part-No.	Material	WP	Claw Distance	Price
CCAP-SS-P	SS 316	10 bar	42mm	

Zubehör

Accessories

Accessoires

Accesorios

Akcesoria

Accessori



Part-No.	Description	Material	DN	Price
CPIN-SS-P	Pin for Couplings (-P)	SS 304	Universal	





Klauenkupplung «US-Ausführung» mit Stutzen und Sicherungsbund mit NBR Dichtung

Claw coupling AMERICAN type with Hose Shank and collar - NBR gasket
 Raccord type Américain cannelé DIN3489 (standard execution) - Joint NBR
 Racor tipo USA- Espiga con cuello de seguridad - Junta NBR
 Złącze kłowe «Typ Amerykański» - z karbowaną końcówką do węży z wiązką zabezpieczającą - NBR Uszczelka
 Raccordo tipo USA portagomma e collare di sicurezza - Guarnizione NBR

Part-No.	Material	WP	Claw Distance	Shank	Price
AK038HE	Steel	10 bar	41mm	7,3mm	
AK050HE	Steel	10 bar	41mm	11mm	
AK075HE	Steel	10 bar	41mm	13mm	
AK100HE	Steel	10 bar	41mm	20mm	



Klauenkupplung «US-Ausführung» mit NPT Außengewinde mit NBR Dichtung

Claw coupling AMERICAN type with NPT male thread - NBR gasket
 Raccord type Américain mâle DIN3489 (standard execution) - Joint NBR
 Racor tipo USA con rosca macho NPT - Junta NBR
 Złącze kłowe «Typ Amerykański» z gwintem zewnętrznym - NBR Uszczelka
 Raccordo tipo USA con filetto maschio NPT - Guarnizione NBR

Part-No.	Material	WP	Claw Distance	Thread	Price
AK038M	Steel	10 bar	41mm	3/8"	
AK050M	Steel	10 bar	41mm	1/2"	
AK075M	Steel	10 bar	41mm	3/4"	
AK100M	Steel	10 bar	41mm	1"	



Klauenkupplung «US-Ausführung» mit NPT Innengewinde mit NBR Dichtung

Claw coupling AMERICAN type with NPT female thread - NBR gasket
 Raccord type Américain femelle DIN3489 (standard execution) - Joint NBR
 Racor tipo USA con rosca hembra NPT - Junta NBR
 Złącze kłowe «Typ Amerykański» z gwintem wewnętrznym - NBR Uszczelka
 Raccordo tipo USA con filetto femmina NPT - Guarnizione NBR



Part-No.	Material	WP	Claw Distance	Thread	Price
AK038F	Steel	10 bar	41mm	3/8"	
AK050F	Steel	10 bar	41mm	1/2"	
AK075F	Steel	10 bar	41mm	3/4"	
AK100F	Steel	10 bar	41mm	1"	

Schlauchklemme 2-teilig, mit losen Zungen und Sicherungsklauen nach DIN20039

Heavy duty double bolts clamp with safety claws - Norm DIN20039
 Collier de serrage double boulons - Norme DIN20039
 Abrazadera doble con garras de seguridad DIN20039 para manguera
 Obejmy dwuczęściowe, z osobnymi wkładkami - «językami» dociskowymi i z zaczepami («pazurami») na kotnierz zabezpieczający końcówki zgodnie DIN20039
 Doppio morsetto con fascette di sicurezza per tubi - DIN20039 Standard



Part-No.	Material	DN	Size	Price
SK29	galvanized steel	13mm	22-29mm	
SK34	galvanized steel	19mm	27-34mm	
SK39	galvanized steel	25mm	32-39mm	

Schlauchklemme 2-teilig nach DIN20039

Heavy duty double bolts clamp - Norm DIN20039
 Collier double boulons - Norme DIN20039
 Abrazadera doble con DIN20039
 Obejmy dwuczęściowe DIN20039
 Doppio morsetto - DIN20039 Standard



Part-No.	Material	DN	Size	Price
SL29	galvanized steel	13mm	22-29mm	
SL34	galvanized steel	19mm	27-34mm	
SL40	galvanized steel	25mm	34-40mm	





Klauenkupplung Typ Express mit Stutzen
mit NBR Dichtung

Claw coupling EXPRESS type with hose shank - NBR gasket
 Raccord Express série forte à douille à gorge - Joint NBR
 Racor tipo Express con espiga - Junta NBR
 Złącze kłowe Typ Express z karbowaną końcówką do węży - NBR Uszczelka
 Raccordo tipo express, portagomma - Guarnizione NBR

Part-No.	Material	WP	Claw Distance	Shank	Price
EXSH13	SS 316	10 bar	41mm	14mm	
EXSH19	SS 316	10 bar	41mm	21mm	
EXSH25	SS 316	10 bar	41mm	27mm	



Klauenkupplung Typ Express mit Außengewinde
mit NBR Dichtung

Claw coupling EXPRESS type with male thread - NBR gasket
 Raccord Express série forte mâle - Joint NBR
 Racor tipo Express con rosca macho - Junta NBR
 Złącze kłowe Typ Express z gwintem zewnętrznym - NBR Uszczelka
 Raccordo tipo Express con filetto maschio - Guarnizione NBR

Part-No.	Material	WP	Claw Distance	Thread	Price
EXSM050	SS 316	10 bar	41mm	1/2"	
EXSM075	SS 316	10 bar	41mm	3/4"	
EXSM100	SS 316	10 bar	41mm	1"	



Klauenkupplung Typ Express mit Innengewinde
mit NBR Dichtung

Claw coupling EXPRESS type with female thread - NBR gasket
 Raccord Express série forte femelle - Joint NBR
 Racor tipo Express con rosca hembra - Junta NBR
 Złącze kłowe Typ Express z gwintem wewnętrznym - NBR Uszczelka
 Raccordo tipo Express con filettato femmina - Guarnizione NBR

Part-No.	Material	WP	Claw Distance	Thread	Price
EXSF050	SS 316	10 bar	41mm	1/2"	
EXSF075	SS 316	10 bar	41mm	3/4"	
EXSF100	SS 316	10 bar	41mm	1"	



Klauenkupplung Typ Express mit Stutzen mit NBR Dichtung

Claw coupling EXPRESS type with hose shank - NBR gasket

Raccord Express série forte à douille à gorge - Joint NBR

Racor tipo Express con espiga - Junta NBR

Złącze kłowe Typ Express z karbowaną końcówką do węży - NBR Uszczelka

Raccordo tipo express, portagomma - Guarnizione NBR



Part-No.	Material	WP	Claw Distance	Shank	Price
EXBH09	Brass	10 bar	41mm	11mm	
EXBH13	Brass	10 bar	41mm	14mm	
EXBH19	Brass	10 bar	41mm	21mm	
EXBH25	Brass	10 bar	41mm	27mm	
EXBH32	Brass	10 bar	41mm	32mm	

Klauenkupplung Typ Express mit Außengewinde mit NBR Dichtung

Claw coupling EXPRESS type with male thread - NBR gasket

Raccord Express série forte mâle - Joint NBR

Racor tipo Express con rosca macho - Junta NBR

Złącze kłowe Typ Express z gwintem zewnętrznym - NBR Uszczelka

Raccordo tipo Express con filetto maschio - Guarnizione NBR



Part-No.	Material	WP	Claw Distance	Thread	Price
EXBM0375	Brass	10 bar	41mm	3/8"	
EXBM050	Brass	10 bar	41mm	1/2"	
EXBM075	Brass	10 bar	41mm	3/4"	
EXBM100	Brass	10 bar	41mm	1"	
EXBM125	Brass	10 bar	41mm	1 1/4"	

NEW





Klauenkupplung Typ Express mit Innengewinde
mit NBR Dichtung

Claw coupling EXPRESS type with female thread - NBR gasket
 Raccord Express série forte femelle - Joint NBR
 Racor tipo Express con rosca hembra - Junta NBR
 Złącze kłowe Typ Express z gwintem wewnętrznym - NBR Uszczelka
 Raccordo tipo Express con filettato femmina - Guarnizione NBR

NEW

Part-No.	Material	WP	Claw Distance	Thread	Price
EXBF0375	Brass	10 bar	41mm	3/8"	
EXBF050	Brass	10 bar	41mm	1/2"	
EXBF075	Brass	10 bar	41mm	3/4"	
EXBF100	Brass	10 bar	41mm	1"	
EXBF125	Brass	10 bar	41mm	1 1/4"	



Klauenkupplung Typ Express - Blindkappe
mit NBR Dichtung

Claw coupling EXPRESS type - blind dust - NBR gasket
 Bouchon express - Joint NBR
 Tapón para acople tipo Express - Junta NBR
 Złącze kłowe zaślepiające Typ Express - NBR Uszczelka
 Tappo per accoppiamento tipo Express - Guarnizione NBR



Part-No.	Material	WP	Claw Distance	DN	Price
EXSC	SS 316	10 bar	41mm	Universal	
EXBC	Brass	10 bar	41mm	Universal	



Schelle für Klauenkupplung Typ Express

Safety bolt Clamp for - Claw coupling EXPRESS type

Collier à griffes pour raccord express

Abrazaderas de seguridad para acople tipo Express

Obejma zaciskowa z kłami zabezpieczający do złączy kłowych Typ Express

Morsetti di sicurezza per accoppiamenti tipo Express



Part-No.	Material	DN	Size	Price
CG17	Steel	DN 17	16-18	
CG23	Steel	DN 23	22-24	
CG26	Steel	DN 26	25-27	
CG29	Steel	DN 29	28-30	
CG32	Steel	DN 32	31-33	
CG36	Steel	DN 36	34-36	
CG38	Steel	DN 38	37-39	



INFORMATIONEN

Sandstrahlarmatur



Die Sandstrahlarmaturen stellen eine hervorragende Lösung für eine einfache und schnelle Verbindung von Sandstrahlschläuchen dar, sowohl untereinander als auch mit dem Sandstrahlgerät.

Sie sind aus besonders strapazierfähigem Nylon gefertigt, was ihnen eine lange Lebensdauer verleiht.

Der Kupplungsmechanismus sorgt für eine zuverlässige Abdichtung und gewährleistet eine stabile Verbindung.

Darüber hinaus sind die Nylon-Schlauchkupplungen mit hochwertigen Dichtungen ausgestattet, die speziell auf die Anforderungen des Sandstrahlens abgestimmt sind.



EINSATZGEBIET

Sandstrahlarmaturen aus Nylon sind die perfekte Lösung für anspruchsvolle Anwendungen in der Oberflächenbearbeitung. Ob in der Automobilindustrie, im Maschinenbau oder in der Metallverarbeitung, unsere Sandstrahlarmaturen bieten Ihnen die Zuverlässigkeit und Leistung, die Sie benötigen, um Ihre Projekte erfolgreich umzusetzen.

INFORMATION

Sandblasting couplings



The sandblasting couplings are an excellent solution for the quick and easy connection of sandblasting hoses, both to each other and to the sandblasting unit.

They are made of particularly hard-wearing nylon, which gives them a long service life. The coupling mechanism ensures a reliable gasket and guarantees a stable

connection.

In addition, the nylon hose couplings are equipped with high-quality gaskets that are specially adapted to the requirements of sandblasting.



AREA OF APPLICATION

Sandblasting couplings made of nylon are the perfect solution for demanding surface treatment applications. Whether in the automotive industry, mechanical engineering or metal processing, our sandblasting fittings offer you the reliability and performance you need to successfully implement your projects.

Sandstrahlarmatur - NBR Dichtung

Sandblast coupling - NBR gasket

Raccord de sablage - Joint NBR

Acoples chorro de arena - Junta NBR

Złącze do piaskowania (kłowe) z końcówką do węży - NBR Uszczelka

Raccordo per sabbiatrice - Guarnizione NBR



SCHWELLKUPPLUNGEN

Part-No.	Material	WP	Length	for Hose	Price
SAB25-N	Nylon	12 bar	93mm	25x7mm	
SAB32-N	Nylon	12 bar	124mm	32x8mm	

Befestigungsschrauben für Sandstrahlarmaturen

Fixing Screw - Sandblast

Vis de fixation pour raccord de sablage

Tornillos de fijación para acoples chorro de arena

Wkręt blokujący do złączy do piaskowania

Viti di fissaggio per raccordi per sabbiatrice



Part-No.	Material	Type	Description	Price
VIS4.8	galvanized Steel	countersunk head screw	4.8x16	





Wasserschlaucharmatur mit Stutzen mit FKM Dichtung

Water hose fitting - with hose shank - FKM gasket

Raccord d'eau à douille annelée - Joint FKM

Racor para agua, espiga - Junta FKM

Złącza kłowe do wody - z karbowaną końcówką do węży - FKM Uszczelka

Raccordo per acqua, portagomma - Guarnizione FKM

Part-No.	Material	WP	Claw Distance	Shank	Price
GH038-SS	SS 316	25 bar	40mm	10mm	
GH050-SS	SS 316	25 bar	40mm	13mm	
GH075-SS	SS 316	25 bar	40mm	19mm	
GH100-SS	SS 316	25 bar	40mm	25mm	
GH125-SS	SS 316	25 bar	40mm	32mm	
GH150-SS	SS 316	25 bar	40mm	38mm	



Wasserschlaucharmatur mit Außengewinde mit FKM Dichtung

Water hose fitting - with male thread - FKM gasket

Raccord d'eau mâle BSP - Joint FKM

Racor para agua - rosca macho - Junta FKM

Złącza kłowe do wody - z gwintem zewnętrznym - FKM Uszczelka

Raccordo per acqua - filetto maschio - Guarnizione FKM

Part-No.	Material	WP	Claw Distance	Thread	Price
GM038-SS	SS 316	25 bar	40mm	3/8"	
GM050-SS	SS 316	25 bar	40mm	1/2"	
GM075-SS	SS 316	25 bar	40mm	3/4"	
GM100-SS	SS 316	25 bar	40mm	1"	
GM125-SS	SS 316	25 bar	40mm	1 1/4"	
GM150-SS	SS 316	25 bar	40mm	1 1/2"	



Wasserschlaucharmatur mit Innengewinde mit FKM Dichtung

Water hose fitting - with female thread - FKM gasket

Raccord d'eau à femelle BSP - Joint FKM

Racor para agua - rosca hembra - Junta FKM

Złącza kłowe do wody - z gwintem wewnętrznym - FKM Uszczelka

Raccordo per acqua - filetto femmina - Guarnizione FKM



Part-No.	Material	WP	Claw Distance	Thread	Price
GF038-SS	SS 316	25 bar	40mm	3/8"	
GF050-SS	SS 316	25 bar	40mm	1/2"	
GF075-SS	SS 316	25 bar	40mm	3/4"	
GF100-SS	SS 316	25 bar	40mm	1"	
GF125-SS	SS 316	25 bar	40mm	1 1/4"	
GF150-SS	SS 316	25 bar	40mm	1 1/2"	

Wasserschlaucharmatur - Kappe mit FKM Dichtung

Water hose fitting - Cap - FKM gasket

Raccord d'eau - Bouchon - Joint FKM

Tapón para agua - Junta FKM

Złącza kłowe do wody - Zaślepka - FKM Uszczelka

Raccordo per acqua - Tappo - Guarnizione FKM



Part-No.	Material	WP	Claw Distance	DN	Price
GBC-SS	SS 316	25 bar	40mm	Universal	





Wasserschlaucharmatur mit Stutzen

mit NBR Dichtung

Water hose fitting - with hose shank - NBR gasket

Raccord d'eau rotatif à douille annelée - Joint NBR

Racor para agua - Espiga - Junta NBR

Złącza kłowe do wody - z karbowaną końcówką do węży - NBR Uszczelka

Raccordo per acqua portagomma - Guarnizione NBR

Part-No.	Material	WP	Claw Distance	Shank	Price
GH038	Brass	10 bar	40mm	10mm	
GH050	Brass	10 bar	40mm	13mm	
GH058	Brass	10 bar	40mm	17mm	
GH075	Brass	10 bar	40mm	19mm	
GH100	Brass	10 bar	40mm	25mm	
GH125	Brass	10 bar	40mm	32mm	
GH150	Brass	10 bar	40mm	38mm	



Wasserschlaucharmatur mit drehbarem Stutzen

mit NBR Dichtung

Water hose fitting - with swivel hose shank - NBR gasket

Raccord d'eau rotatif à douille annelée - Joint NBR

Racor para agua - espiga giratoria - Junta NBR

Złącza kłowe do wody - z karbowaną końcówką do węży - NBR Uszczelka

Raccordo per acqua - portagomma girevole - Guarnizione NBR

NEW

Part-No.	Material	WP	Claw Distance	Shank	Price
GH050-SW	Brass	10 bar	40mm	13mm	
GH075-SW	Brass	10 bar	40mm	19mm	
GH100-SW	Brass	10 bar	40mm	25mm	



Wasserschlaucharmatur mit Verschraubungsring und Stutzen mit NBR Dichtung

Water hose fitting - with hose shank and adjustabel ring - NBR gasket

Raccord d'eau à douille annelée et bague d'ajustement - Joint NBR

Racor para agua - con anillo de ajuste - Junta NBR

Złącza kłowe do wody - z karbowaną końcówką do węża i pierścień regulacyjny - NBR Uszczelka

Raccordo per acqua portagomma e anello di regolazione - Guarnizione NBR



NEW

Part-No.	Material	WP	Claw Distance	Shank	Price
GH050-AD	Brass	10 bar	40mm	13mm	
GH075-AD	Brass	10 bar	40mm	19mm	
GH100-AD	Brass	10 bar	40mm	25mm	

Wasserschlaucharmatur mit Stutzen (90° Bogen) mit NBR Dichtung

Water hose fitting - with hose shank (90° Elbow) - NBR gasket

Raccord d'eau à douille annelée 90° - Joint NBR

Racor para agua - Espiga 90° - Junta NBR

Złącza kłowe do wody - z karbowaną końcówką do węża 90° - NBR Uszczelka

Raccordo per acqua portagomma 90° - Guarnizione NBR



NEW

Part-No.	Material	WP	Claw Distance	Shank	Price
GH075-90	Brass	10 bar	40mm	19mm	

Wasserschlaucharmatur mit Schlauchverbinder mit NBR Dichtung

Water hose fitting - with hose connector - NBR gasket

Raccord d'eau avec connecteur de tuyau - Joint NBR

Racor para agua - conector de manguera - Junta NBR

Złącza kłowe do wody - złącze węża - NBR Uszczelka

Raccordo per acqua connettore del tubo flessibile - Guarnizione NBR



NEW

Part-No.	Material	WP	Claw Distance	Hose	Price
GHC075	Brass	10 bar	40mm	13mm	





Wasserschlaucharmatur mit Außengewinde
mit NBR Dichtung

Water hose fitting - with male thread - NBR gasket
 Raccord d'eau à mâle BSP - Joint NBR
 Racor para agua - rosca macho - Junta NBR
 Złącza kłowe do wody - z gwintem zewnętrznym - NBR Uszczelka
 Raccordo per acqua - filetto maschio - Guarnizione NBR

Part-No.	Material	WP	Claw Distance	Thread	Price
GM038	Brass	10 bar	40mm	3/8"	
GM050	Brass	10 bar	40mm	1/2"	
GM075	Brass	10 bar	40mm	3/4"	
GM100	Brass	10 bar	40mm	1"	
GM125	Brass	10 bar	40mm	1 1/4"	
GM150	Brass	10 bar	40mm	1 1/2"	



Wasserschlaucharmatur mit Außengewinde und Verschraubungsring
mit NBR Dichtung

Water hose fitting - with male thread and adjustabel ring - NBR gasket
 Raccord d'eau mâle BSP et bague d'ajustement- Joint NBR
 Racor para agua - Con rosca macho y anillo de ajuste - Junta NBR
 Złącza kłowe do wody - z gwintem zewnętrznym i pierścień regulacyjny - NBR Uszczelka
 Raccordo per acqua - filetto maschio e anello di regolazione - Guarnizione NBR

NEW

Part-No.	Material	WP	Claw Distance	Thread	Price
GM075-AD	Brass	10 bar	40mm	3/4"	



Wasserschlaucharmatur mit drehbarem Innengewinde
mit NBR Dichtung

Water hose fitting - with swivel female thread - NBR gasket
 Raccord d'eau rotatif femelle BSP - Joint NBR
 Racor giratorio para agua - rosca hembra - Junta NBR
 Złącza kłowe do wody - z obrótowym gwintem wewnętrznym - NBR Uszczelka
 Raccordo girevole per acqua - filetto femmina - Guarnizione NBR

NEW

Part-No.	Material	WP	Claw Distance	Thread	Price
GF075-SW	Brass	10 bar	40mm	3/4"	9,16 €



Wasserschlaucharmatur mit Innengewinde mit NBR Dichtung

Water hose fitting - with female thread - NBR gasket

Raccord d'eau femelle BSP - Joint NBR

Racor para agua - rosca hembra - Junta NBR

Złącza kłowe do wody - z gwintem wewnętrznym - NBR Uszczelka

Raccordo per acqua - filetto femmina - Guarnizione NBR



Part-No.	Material	WP	Claw Distance	Thread	Price
GF038	Brass	10 bar	40mm	3/8"	
GF050	Brass	10 bar	40mm	1/2"	
GF075	Brass	10 bar	40mm	3/4"	
GF100	Brass	10 bar	40mm	1"	
GF125	Brass	10 bar	40mm	1 1/4"	
GF150	Brass	10 bar	40mm	1 1/2"	

Wasserschlaucharmatur - Kappe mit NBR Dichtung

Water hose fitting - Cap - NBR gasket

Raccord d'eau - Bouchon - Joint NBR

Racor para agua - Tapón - Junta NBR

Złącza kłowe do wody - Zaślepka - NBR Uszczelka

Tappo - Guarnizione NBR



Part-No.	Material	WP	Claw Distance	DN	Price
GBC	Brass	10 bar	40mm	Universal	

Wasserschlaucharmatur - Y-Verteilerstück mit NBR Dichtung

Water hose fitting - Y - NBR gasket

Raccordement de tuyaux d'eau - Y - Joint NBR

Racor para agua - Bifurcación - Junta NBR

Złącza kłowe do wody - Zaślepka - NBR Uszczelka

Raccordo a Y - Guarnizione NBR



Part-No.	Material	WP	Claw Distance	DN	Price
GKY	Brass	10 bar	40mm	Universal	





1/3 Verschraubung mit AG und gerilltem Schlauchstutzen

Brass garden hose shank with male thread and serrated hose shank

Raccord union 1/3 avec filetage mâle et raccord de tuyau rainuré

Racor con rosca macho 1/3 y espiga dentada

1/3 Króciec do węża z gwintem zewnętrznym

Portagomma con filetto maschio

Part-No.	Material	WP	Thread	Shank	Price
1/3H050	Brass	10 bar	1/2"	13 mm	
1/3H075-050	Brass	10 bar	3/4"	13 mm	
1/3H075	Brass	10 bar	3/4"	19 mm	
1/3H100-075	Brass	10 bar	1"	19 mm	
1/3H100	Brass	10 bar	1"	25 mm	



2/3 Verschraubung mit IG und gerilltem Schlauchstutzen

mit NBR Dichtung

Brass garden hose shank with female thread and serrated hose shank - NBR gasket

Raccord fileté 2/3 avec taraudage femelle et raccord de tuyau rainuré - Joint NBR

Racor con rosca hembra 2/3 y espiga dentada - Junta NBR

2/3 Króciec do węża z gwintem wewnętrznym - NBR Uszczelka

Portagomma con filetto femmina - Guarnizione NBR

Part-No.	Material	WP	Thread	Shank	Price
2/3H050	Brass	10 bar	1/2"	13mm	
2/3H075-050	Brass	10 bar	3/4"	13 mm	
2/3H075	Brass	10 bar	3/4"	19 mm	
2/3H100-075	Brass	10 bar	1"	19 mm	
2/3H100	Brass	10 bar	1"	25 mm	



Verschraubung Standard - Sauger - BSPP Außengewinde

mit kurzem gerilltem Stutzen

Brass male fitting standard - BSPP male thread - with short serrated hose shank

Raccordement mâle en laiton standard - filetage mâle BSPP - Avec queue de tuyau courte et rainurée

Conexión rosca macho BSPP - espiga corta

Króciec do węża z gwintem zewnętrznym BSPP - ssawka - krótki ogon

Raccordo maschio - filetto maschio BSPP - portagomma corto



Part-No.	Material	WP	Thread	Shank	Shank Length	Price
SG13BRK	Brass	10 bar	1/2"	13mm	27mm	
SG1319BRK	Brass	10 bar	1/2"	19mm	27mm	
SG19BRK	Brass	10 bar	3/4"	19mm	29mm	
SG1925BRK	Brass	10 bar	3/4"	25mm	29mm	
SG25BRK	Brass	10 bar	1"	25mm	33mm	
SG2513BRK	Brass	10 bar	1"	13mm	32mm	
SG2519BRK	Brass	10 bar	1"	19mm	32mm	
SG32BRK	Brass	10 bar	1 1/4"	32mm	37mm	
SG40BRK	Brass	10 bar	1 1/2"	39mm	41mm	
SG50BRK	Brass	10 bar	2"	51mm	54mm	

Verschraubung schwere Ausführung - Sauger - BSPP Außengewinde

mit langem gerilltem Stutzen

Brass male fitting heavy version - BSPP male thread - long serrated hose shank

Raccordement mâle en laiton version forte - filetage mâle BSPP - douille longue et annelée

Conexión rosca macho BSPP versión pesada - espiga larga

Króciec do węża - ciężka wersja - z gwintem zewnętrznym BSPP - ssawka - długi ogon

Raccordo maschio versione pesante - filettato maschio BSPP - portagomma lungo



Part-No.	Material	WP	Thread	Shank	Shank Length	Price
SG13BRL	Brass	20 bar	1/2"	15 mm	47 mm	
SG19BRL	Brass	20 bar	3/4"	21mm	48 mm	
SG25BRL	Brass	20 bar	1"	27 mm	48 mm	
SG32BRL	Brass	20 bar	1 1/4"	33,5 mm	70,5 mm	
SG40BRL	Brass	20 bar	1 1/2"	40,3 mm	55 mm	
SG50BRL	Brass	20 bar	2"	50,8 mm	64 mm	
SG75BRL	Brass	20 bar	3"	77 mm	75 mm	
SG100BRL	Brass	20 bar	4"	102,2 mm	96 mm	





Verschraubung Standard - Sauger - BSPP Innengewinde

mit kurzem gerilltem Stutzen

Brass female fitting standard - BSPP female thread - with short serrated hose shank

Raccord femelle en laiton standard - filetage femelle BSPP - avec douille annelé courte

Conexión rosca hembra BSPP - espiga corta

Króciec do węża z gwintem wewnętrznym BSPP - ssawka - krótki ogon

Raccordo femmina - filetto femmina BSPP - portagomma corto

Part-No.	Material	WP	Thread	Shank	Shank Length	Price
SGF13BRK	Brass	10 bar	1/2"	13 mm	27 mm	
SGF19BRK	Brass	10 bar	3/4"	19 mm	29mm	
SGF25BRK	Brass	10 bar	1"	25 mm	33 mm	
SGF32BRK	Brass	10 bar	1 1/4"	32 mm	37 mm	
SGF40BRK	Brass	10 bar	1 1/2"	39 mm	41 mm	
SGF50BRK	Brass	10 bar	2"	51 mm	54 mm	



Mutterteil Verschraubung - Sauger - BSPP Innengewinde

mit gerilltem Stutzen

Female fitting standard - BSPP female thread - with serrated hose shank -

Raccordement femelle standard - filetage femelle BSPP - avec douille annelée

Conexión hembra - Rosca hembra BSPP - espiga dentada

Złącze żeńskie - ssawka - gwint wewnętrzny BSPP - z rowkowanym króćcem

Raccordo femmina - filetto femmina BSPP - portagomma

Part-No.	Material	WP	Thread	Shank	Price
SFPP13SWC	Polypropylen	8,5 bar	1/2"	15 mm	
SFPP19SWC	Polypropylen	8,5 bar	3/4"	20 mm	
SFPP25SWC	Polypropylen	8,5 bar	1"	26 mm	
SFPP32SWC	Polypropylen	6,5 bar	1 1/4"	33 mm	
SFPP38SWC	Polypropylen	6,5 bar	1 1/2"	40 mm	
SFPP50SWC	Polypropylen	6,5 bar	2"	51,7 mm	
SFPP75SWC	Polypropylen	5 bar	3"	76,8 mm	
SFPP100SWC	Polypropylen	5 bar	4"	101,7 mm	



Vaterteil Verschraubung - Sauger - BSPP Außengewinde mit gerilltem Stutzen

Male fitting standard - BSPP male thread - with serrated hose shank

Filetage mâle standard - filetage mâle BSPP - avec douille annelée

Conexión macho - Rosca macho BSPP - espiga dentada

Złącze męskie - ssawka - gwintem zewnętrzny BSPP - z rowkowanym króćcem

Raccordo maschio - filetto maschio BSPP - portagomma



SCHWELLKUPPLUNGEN

Part-No.	Material	WP	Thread	Shank	Price
SMPP13SWC	Polypropylen	8,5 bar	1/2"	15 mm	
SMPP19SWC	Polypropylen	8,5 bar	3/4"	20 mm	
SMPP25SWC	Polypropylen	8,5 bar	1"	26 mm	
SMPP32SWC	Polypropylen	6,5 bar	1 1/4"	33 mm	
SMPP38SWC	Polypropylen	6,5 bar	1 1/2"	40 mm	
SMPP50SWC	Polypropylen	6,5 bar	2"	51,7 mm	
SMPP75SWC	Polypropylen	5 bar	3"	76,8 mm	
SMPP100SWC	Polypropylen	5 bar	4"	101,7 mm	

PE Fasshahn mit Außengewinde

Polyethylen Barrel Tap with BSPP male thread

Robinet de fût PE avec filetage mâle

Grifo de PE para barril con rosca macho

Kran beczkowy PE z gwintem zewnętrznym

Rubinetto da barile in PE con filettatura maschio



Part-No.	Material	Description	WP	DN	Thread	Price
BSPM075TAP	Polypropylen	without Gasket	8,5 bar	DN19	3/4"	
BSPM200TAP	Polypropylen	with Gasket	8,5 bar	DN50	2"	



INFORMATIONEN

Wasserschlaucharmaturen



Es gibt Systeme, die stellen den ultimativen Standard im Garten- und Industriebereich dar. Steckverbindungen in robusten Kunststoff sind fast in jedem Haushalt bzw. Garten anzutreffen.

Dieses System von MCC dient als gleichwertige Ergänzung zum bekannten Original eines anderem namenhaften

Herstellers.

MCC bietet eine hohe Anzahl von Schlauchanschlüssen, die auf die industriellen Schläuche mit unterschiedlichen Wanddicken ausgelegt sind.

Diese sind an den verschiedensten Stellen im Katalog zu finden. Mit Hilfe von schlauchseitigen Außen- oder

Innengewinden kann an dieses System adaptiert werden.

WARUM MCC?

- Robuster Kunststoff in hochwertiger Qualität
- Stellventile statt Rückschlagventile zur Optimierung der Bedienung und des Volumenstromes
- Teilweise doppelt ausgelegte O-Ring Abdichtungen für optimierte Dichtigkeit
- Verschiedenste Verschluss- und Verteilersysteme, auch separate Kugelhähne
- Viele Kombinationsmöglichkeiten und Anschlussausführungen
- In dem Strömungskämen sind keine Einbauten, die den Volumenstrom reduzieren. Somit ist der ärgerliche Druckverlust auf ein Minimum reduziert.



TECHNISCHE INFORMATIONEN

- Komplett kompatibel zum bekannten Standard
- Gewinde: zölliges ISO 228 Rohrgewinde flachdichtend in 1/2" und 3/4"
- Auch M 18 x 1,5 verfügbar
- Teilweise Sechskant als Schlüsselfläche
- EPDM-O-Ring Abdichtung
- Stellventile mit Kunststoffdichtung

EINSATZGEBIET

- Wasserverteiler
Förderung von Medien, die Metalle angreifen.
Netzwerke für die Wasserverteilung
Industrie und Baugewerbe
Gartenbetriebe
Dosiersystem
Bypass-Systeme

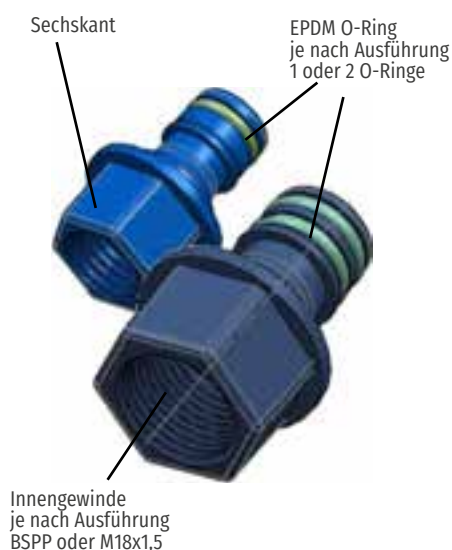



INFORMATION

Water Hose Fittings

The systems represents the ultimate standard in the garden and industrial sector. Plug connections in robust plastic can be found in almost every household or garden.

original from another well-known manufacturer.

MCC offers a large number of hose connectors that are designed for industrial hoses with different wall thicknesses.

with the aid of external or internal threads on the hose side.

This system from MCC serves as an equivalent supplement to the well-known

These can be found in various places in the catalog. This system can be adapted

WHY MCC?

- Robust plastic in high quality
- Control valves instead of non-return valves to optimize operation and volume flow
- Partially double O-ring gaskets for optimized tightness
- Various closure and manifold systems, including separate ball valves
- Many possible combinations and connection designs
- There are no fittings in the flow ducts that reduce the volume flow. This reduces the annoying pressure loss to a minimum.



TECHNICAL INFORMATION

- Fully compatible with the known standard
- Thread: Inch ISO 228 pipe thread, flat-sealing in 1/2" and 3/4"
- M 18 x 1.5 also available
- Partially hexagonal as key surface
- EPDM O-ring gasket
- Control valves with plastic gasket

AREA OF APPLICATION

- Water distributor
- Delivery of media that corrode metals.
- Networks for water distribution
- Industry and construction
- Gardening
- Dosing system
- Bypass systems

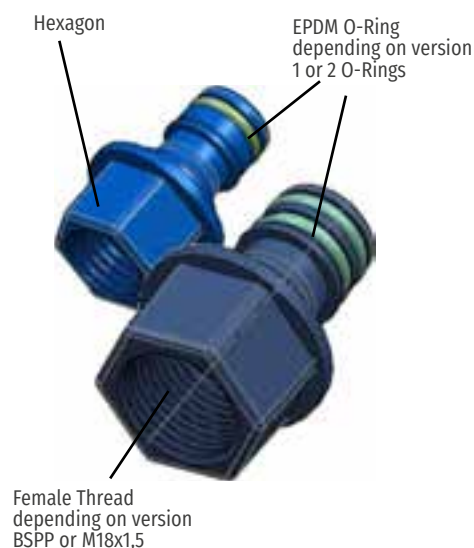

Zapfpistole Polypropylen

Nozzle polypropylene
 Pistolet de distribution PP
 Boquerel de PP
 Dysza PP
 Pistola di riempimento in PP

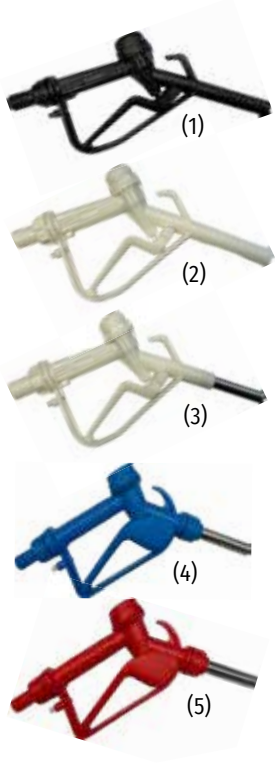

Part-No.	Description	WP	Inlet	Outlet	Price
NZP100HTP075	(1) Black - PP outlet Medium: diesel, kerosene, no corrosive liquid	5 bar	3/4"	1"	
NZP100HTP100	(1) Black - PP outlet Medium: diesel, kerosene, no corrosive liquid	5 bar	1"	1"	
NZP100HTP075-W	(2) White - PP outlet Medium: diesel, gasoline, kerosene, AdBlue and other low corrosive liquids	5 bar	3/4"	1"	
NZP100HTP100-W	(2) White - PP outlet Medium: diesel, gasoline, kerosene, AdBlue and other low corrosive liquids	5 bar	1"	1"	
NZS075HTP075-W	(3) White - SS304 outlet Medium: diesel, gasoline, kerosene, AdBlue and other low corrosive liquids	5 bar	3/4"	3/4"	
NZS075HTP100-W	(3) White - SS304 outlet Medium: diesel, gasoline, kerosene, AdBlue and other low corrosive liquids	5 bar	1"	3/4"	
NZS075HTP075-B	(4) Blue - FSS304 outlet Medium: diesel, gasoline, kerosene, AdBlue and other low corrosive liquids	5 bar	3/4"	3/4"	
NZS075HTP075-R	(5) Red - SS304 outlet Medium: diesel, gasoline, kerosene, AdBlue and other low corrosive liquids	5 bar	3/4"	3/4"	

10 bar Platzdruck
 10 bar Burst pressure

Zapfpistole mit Schlauch

Nozzle PP with Hose
 Pistolet de distribution PP avec tuyau
 Boquerel de PP con manguera
 Dysza PP z wężem
 Pistola di riempimento in PP con tubo flessibile



Part-No.	Hose	WP	Side 1	Side 2	Price
NZS075IBCF60-2M	PVC black, 2 m	5 bar	white PP Nozzle Outlet 3/4" in SS304	IBC S60X6 female thread, black	

10 bar Platzdruck
 10 bar Burst pressure



Kugelhahn - IG/IG, voller Durchgang

Ball valve female / female BSP, full passage

Vanne 2 pièces passage intégral femelle/femelle BSP -

Válvula de bola hembra / hembra BSP

Zawór kulowy z gwintami wewnętrznymi z pełnym przelotem

Valvola a sfera femmina / femmina BSP

Part-No.	Colour	Material	WP	Thread	Shank	Price
PBV050-B	Blue	PVC	10 bar	DN15	1/2"	
PBV075-B	Blue	PVC	10 bar	DN19	3/4"	
PBV100-B	Blue	PVC	10 bar	DN25	1"	
PBV125-B	Blue	PVC	10 bar	DN32	1 1/4"	
PBV150-B	Blue	PVC	10 bar	DN38	1 1/2"	
PBV200-B	Blue	PVC	10 bar	DN50	2"	
PBV250-B	Blue	PVC	10 bar	DN65	2 1/2"	
PBV300-B	Blue	PVC	10 bar	DN80	3"	
PBV400-B	Blue	PVC	10 bar	DN100	4"	
PBV050-W	White	PVC	10 bar	DN15	1/2"	
PBV075-W	White	PVC	10 bar	DN19	3/4"	
PBV100-W	White	PVC	10 bar	DN25	1"	
PBV125-W	White	PVC	10 bar	DN32	1 1/4"	
PBV150-W	White	PVC	10 bar	DN38	1 1/2"	
PBV200-W	White	PVC	10 bar	DN50	2"	
PBV250-W	White	PVC	10 bar	DN65	2 1/2"	
PBV300-W	White	PVC	10 bar	DN80	3"	
PBV400-W	White	PVC	10 bar	DN100	4"	
PBV050-G	Grey	PVC	10 bar	DN15	1/2"	
PBV075-G	Grey	PVC	10 bar	DN19	3/4"	
PBV100-G	Grey	PVC	10 bar	DN25	1"	
PBV125-G	Grey	PVC	10 bar	DN32	1 1/4"	
PBV150-G	Grey	PVC	10 bar	DN38	1 1/2"	
PBV200-G	Grey	PVC	10 bar	DN50	2"	
PBV250-G	Grey	PVC	10 bar	DN65	2 1/2"	
PBV300-G	Grey	PVC	10 bar	DN80	3"	
PBV400-G	Grey	PVC	10 bar	DN100	4"	



20 bar Platzdruck

20 bar Burst pressure

Kupplungsdichtung
Gewindedichtungab Seite 407
ab Seite 419Gasket for coupling
Thread gasketpage 407
page 419

Gartenschlauchzubehör - Adapter

Garden hose accessories - adapters
 Accessoires pour tuyaux d'arrosage - Adaptateur
 Accesorios para mangueras de jardín - Adaptador
 Akcesoria do węży ogrodowych - Adapter
 Accessori per tubi da giardino - Adattatore



Part-No.	Description	WP	Size1	Size 2	Price
GQCM1BSPF050	Adapter Plastic - black	8 bar	QC Male 1 O-Ring	Female BSPP 1/2"	
GQCM1BSPF050-2	Adapter Plastic - grey/orange	8 bar	QC Male 1 O-Ring	Female BSPP 1/2"	
GQCM1BSPF050HEX	Adapter Plastic - grey	8 bar	QC Male 1 O-Ring	Female BSPP 1/2"	
GQCM1BSPF075-2	Adapter Plastic - grey/orange	8 bar	QC Male 1 O-Ring	Female BSPP 3/4"	
GQCM1BSPM075	Adapter Plastic - black	8 bar	QC Male 1 O-Ring	Male BSPP 3/4"	
GQCM2BSPF050HEX	Adapter Plastic - grey	8 bar	QC Male 2 O-Ring	Female BSPP 1/2"	
GQCM1M18HEX	Adapter Plastic - grey	8 bar	QC Male 1 O-Ring	Female M18*1,5	
GQCM2M18HEX	Adapter Plastic - grey	8 bar	QC Male 2 O-Ring	Female M18*1,5	
GDBSPF100QCM1-4	Divider Plastic - black/red	8 bar	Female BSPP 1"	4xQC Male 1 O-Ring	
GRBSPFF075075	Regulator Plastic - grey/orange	8 bar	Female BSPP 3/4"	Female BSPP 3/4"	
GRBSPMM075075	Regulator Plastic - grey/orange	8 bar	Male BSPP 3/4"	Male BSPP 3/4"	
GRQCFF	Regulator Plastic - grey/orange	8 bar	QC Female	QC Female	
GRQCFM1	Regulator Plastic - grey/orange	8 bar	QC Female	QC Male 1 O-Ring	
GRQCM1M1	Regulator Plastic - grey/orange	8 bar	QC Male 1 O-Ring	QC Male 1 O-Ring	

20 bar Platzdruck
 20 bar Burst pressure



Barcelona Kupplung (UNE 23400), geschmiedete Ausführung
mit BSPP Innengewinde - NBR Dichtung

Barcelona coupling (UNE 23400), forged, with female BSPP thread - NBR gasket
Raccord Barcelona (UNE 23400), forgé, avec taraudage femelle BSPP - Joint NBR
Barcelona, estampado (UNE 23400), con rosca hembra BSPP - Junta NBR
Złącze Barcelona (UNE 23400), wykute, z gwintem wewnętrznym BSPP - NBR Uszczelka
Barcelona stampato (UNE 23400) con filetto femmina BSPP - Guarnizione NBR



Part-No.	Material	WP	Thread	Thread	Price
BACO25F100	Aluminum	16 bar	DN25	1"	
BACO45F150	Aluminum	16 bar	DN45	1 1/2"	
BACO70F250	Aluminum	16 bar	DN70	2 1/2"	

Barcelona Kupplung (UNE 23400), geschmiedete Ausführung
mit BSPP Außengewinde - NBR Dichtung

Barcelona coupling (UNE 23400), forged, with male BSPP thread - NBR gasket
Raccord Barcelona (UNE 23400), forgé, avec filetage mâle BSPP - Joint NBR
Barcelona, estampado (UNE 23400), con rosca macho BSPP - Junta NBR
Złącze Barcelona (UNE 23400), wykute, z gwintem zewnętrznym BSPP - NBR Uszczelka
Barcelona stampato (UNE 23400) con filetto maschio BSPP - Guarnizione NBR



Part-No.	Material	WP	Thread	Thread	Price
BACO25M100	Aluminum	16 bar	DN25	1"	
BACO45M150	Aluminum	16 bar	DN45	1 1/2"	
BACO70M250	Aluminum	16 bar	DN70	2 1/2"	

Barcelona Kupplung (UNE 23400), geschmiedete Ausführung
mit Schlauchstutzen - NBR Dichtung

Barcelona coupling (UNE 23400), forged, with hose shank - NBR gasket
Raccord Barcelona (UNE 23400), forgé, avec douille pour tuyau flexible - Joint NBR
Barcelona (UNE 23400), estampado, con espiga para manguera - Junta NBR
Złącze Barcelona (UNE 23400), wykute, z karbowaną końcówką do węża - NBR Uszczelka
Barcelona stampato (UNE 23400) portagomma - Guarnizione NBR



Part-No.	Material	WP	Thread	Shank	Price
BACO25HT100	Aluminum	16 bar	DN25	25mm	
BACO45HT150	Aluminum	16 bar	DN45	45mm	
BACO70HT250	Aluminum	16 bar	DN70	70mm	





Barcelona Kupplung (UNE 23400), geschmiedete Ausführung

Reduzierung - NBR Dichtung

Barcelona coupling (UNE 23400), forged, reducer - NBR gasket

Raccord Barcelona (UNE 23400), forgé, réduction - Joint NBR

Reducción Barcelona (UNE 23400), estampado - Junta NBR

Złącze Barcelona (UNE 23400), wykute, redukcja - NBR Uszczelka

Riduzione Barcelona (UNE 23400), stampato - Guarnizione NBR

Part-No.	Material	WP	DN	DN	Price
BACO2545RED	Aluminum	16 bar	DN25	DN45	
BACO4570RED	Aluminum	16 bar	DN45	DN70	



Barcelona Kappe, gegossene Ausführung

mit Kette - NBR Dichtung

Barcelona Cap - with chain - NBR gasket

Bouchon Barcelona - avec chaîne - Joint NBR

Tapón Barcelona con cadena - Junta NBR

Pokrywka z łańcuszkiem do złączy Barcelona, wersja odlewana - NBR Uszczelka

Tappo Barcelona con catena - Guarnizione NBR

Part-No.	Material	WP	DN	Price
BACO25DC	Aluminum	16 bar	DN25	
BACO45DC	Aluminum	16 bar	DN45	
BACO70DC	Aluminum	16 bar	DN70	



The background of the page is a detailed architectural floor plan in a light blue color. It features various rooms, corridors, and structural elements, including several circular areas that could be auditoriums or theaters. The drawing is technical and precise, showing walls, doors, and furniture layouts.

IBC-ARMATUREN

INFORMATIONEN

IBC Armaturen



Das S60x6 Gewinde ist das Standard-gewinde an IBC Auslaufstutzen.

Das Sägezahn-gewinde hat sehr geringe Querkräfte, so dass verschraubte Kunststoffteile auch mit geringer Wanddicke die Kräfte übertragen können.

Bezogen auf diesen Gewinde-anschluss sind eine Vielzahl von Anschluss

Adaptoren im Gebrauch, um von diesem Standard auf die eigenen Kupplungen umzusetzen.

Erforderlich sind Hähne, Tüllen, Lebensmittelanschlüsse und vieles mehr, damit der IBC gefüllt oder entleert werden kann.

Auf Anfrage können sogar Lanzensysteme

zum Einfüllen oder Leersaugen, Gaspendelungen oder auch Probenahmesysteme aus den reichhaltigen Armaturen von MCC kombiniert werden

Die Armaturen stehen in Kunststoff und in Edelstahl zur Verfügung

WARUM MCC?

- Das S60x6 Gewinde wird mit Prüfadaptoren kontrolliert, damit die Fittinge immer passen
- Eine sehr große Anzahl von Variationsmöglichkeiten zum Kombinieren von Anschlüssen
- Kugelhähne oder Verschlußsysteme zum kontrollierten Ent- oder Beladen)
- Große Anzahl von Dichtungen, Fittinge in Edelstahl und Kunststoff erweitern die Variantenmöglichkeit
- S60x6 Fittinge mit Lebensmittelanschlüssen verfügbar



TECHNISCHE INFORMATIONEN

- Normen: DIN 513, 6mm Steigung Flankenwinkel 33°
- Innen- und Außengewinde
- Betriebsdruck: -0,8 bis 16 bar bei 65°C
- Anschlüsse nach den Normen ISO 228 Rohrgewinde, DIN EN 11851 Rundgewinde, DIN 32676 Tri Clamp, DIN EN 14420 Schlauchanschlüsse, Kamlok

EINSATZGEBIET

IBC Container gibt es in weiß elektrostatisch isolierend und in schwarz antistatisch.

IBC dienen zum Lagern und Transportieren von Flüssigkeiten. Überdrücke auch durch Temperaturschwankungen sind zu vermeiden.

Adapter sind die wichtigsten Armaturen, um die Schnittstelle zwischen eigenen Schlauchanschlüssen und dem IBC Container definieren zu können

Adapter IBC auf BSP Innengewinde



IBC Außengewinde



INFORMATION

IBC couplings

The S60x6 thread is the standard thread on IBC couplings.

The saw-tooth thread has very low lateral forces, so that screwed plastic parts can transmit the forces even with low wall thickness.

Taps, spouts, food connections and much more are required so that the IBC

can be filled or emptied.

On request, it is even possible to combine lance systems for filling or emptying, vapor recovery systems or even sampling systems from MCC's extensive range of fittings.

The fittings are available in plastic and stainless steel.

WHY MCC?

- The S60x6 thread is controlled with test adapters so that the fittings always fit
- A very large number of options for combining connections
- Ball valves or locking systems for controlled unloading or loading
- Large number of gaskets, couplings in stainless steel and plastic extend the range of possible variants
- S60x6 fittings with food connections available



TECHNICAL INFORMATION

- Normen: DIN 513, 6mm Steigung Flankenwinkel 33°
- Internal and external thread
- Operating pressure: -0.8 to 16 bar at 65°C
- Connections in accordance with ISO 228 pipe thread, DIN EN 11851 round thread, DIN 32676 Tri Clamp, DIN EN 14420 hose connections, Kamlok

AREA OF APPLICATION

IBC containers are available in white electrostatically insulating and in black antistatic.

IBC couplings are used to store and transport liquids. Overpressure, also due to temperature fluctuations, must be avoided.

Adapters are the most important fittings for defining the interface between your own hose connections and the IBC container

Adapter IBC - BSP female thread



IBC male thread



IBC Innengewinde mit BSPP Innengewinde ohne Dichtung

IBC female thread with BSPP female thread - without gasket
 Taraudage IBC femelle avec taraudage BSPP femelle - Sans joint
 Adaptador rosca hembra IBC con rosca hembra BSPP - Sin Junta
 Złącze IBC obustronnie z gwintem wewnętrznym - Bez Uszczelka:
 Accoppiamento filettato femmina IBC con filetto femmina BSPP - Senza guarnizione

Part-No.	Material	WP	IBC	Thread	Price
IBCF60BSPF100-SS	SS 1.4404	16 bar	S60x6	1"	
IBCF60BSPF125-SS	SS 1.4404	16 bar	S60x6	1 1/4"	
IBCF60BSPF150-SS	SS 1.4404	16 bar	S60x6	1 1/2"	
IBCF60BSPF200-SS	SS 1.4404	16 bar	S60x6	2"	
IBCF60BSPF250-SS	SS 1.4404	16 bar	S60x6	2 1/2"	
IBCF60BSPF300-SS	SS 1.4404	16 bar	S60x6	3"	



IBC Innengewinde mit BSPP Außengewinde ohne Dichtung

IBC female thread with BSPP male thread - without gasket
 Taraudage IBC femelle avec filetage BSPP mâle - sans joint
 Adaptador rosca hembra IBC con rosca macho BSPP - sin junta
 Złącze IBC z gwintem wewnętrznym i z gwintem zewnętrznym BSPP - bez Uszczelka
 Accoppiamento filettato femmina IBC con filetto maschio BSPP - senza guarnizione

Part-No.	Material	WP	IBC	Thread	Price
IBCF60BSPM100-SS	SS 1.4404	16 bar	S60x6	1"	
IBCF60BSPM125-SS	SS 1.4404	16 bar	S60x6	1 1/4"	
IBCF60BSPM150-SS	SS 1.4404	16 bar	S60x6	1 1/2"	
IBCF60BSPM200-SS	SS 1.4404	16 bar	S60x6	2"	
IBCF60BSPM250-SS	SS 1.4404	16 bar	S60x6	2 1/2"	
IBCF60BSPM300-SS	SS 1.4404	16 bar	S60x6	3"	



Übergangsstück Kamlok Vaterteil auf IBC Innengewinde ohne Dichtung

Adapter camlock male type to IBC female thread - without gasket

Adaptateur camlock mâle sur raccord IBC taraudé femelle - sans joint

Adaptador Camlock macho con rosca hembra IBC - sin junta

Adapter camlock typ męski do złączek doczołowych IBC gwint wewnętrzny - bez Uszczelka

Adattatore Camlock maschio con filettato femmina IBC - senza guarnizione



Part-No.	Material	WP	C&G	IBC	Price
IBCF60A100-SS	SS 1.4404	16 bar	DN25	S60x6	
IBCF60A125-SS	SS 1.4404	16 bar	DN32	S60x6	
IBCF60A150-SS	SS 1.4404	16 bar	DN40	S60x6	
IBCF60A200-SS	SS 1.4404	16 bar	DN50	S60x6	

IBC Außengewinde mit DIN 11851 Außengewinde

IBC male thread with male DIN 11851

Filetage IBC mâle avec Mâle DIN 11851

Adaptador rosca macho IBC con macho DIN 11851

Złącze IBC z gwintem zewnętrznym / Wtyk Część Męska DIN11851

Adattatore filettato maschio IBC con maschio DIN 11851



Part-No.	Material	WP	IBC	DIN	Price
IBCM60DINM25-SS	SS 1.4404	16 bar	S60x6	DN25	
IBCM60DINM32-SS	SS 1.4404	16 bar	S60x6	DN32	
IBCM60DINM40-SS	SS 1.4404	16 bar	S60x6	DN40	
IBCM60DINM50-SS	SS 1.4404	16 bar	S60x6	DN50	
IBCM60DINM65-SS	SS 1.4404	16 bar	S60x6	DN65	
IBCM60DINM80-SS	SS 1.4404	16 bar	S60x6	DN80	





IBC Innengewinde mit Vaterteil DIN 11851

ohne Dichtung

IBC female thread with male DIN 11851 - without gasket

Taroudage IBC femelle avec Mâle DIN 11851 - sans jointt

Adaptador rosca hembra IBC con macho DIN 11851 - sin junta

Złącze IBC z gwintem wewnętrznym / Wtyk Część Męska DIN11851 - bez Uszczelka

Adattatore filettato femmina IBC con maschio DIN 11851 - senza guarnizione

Part-No.	Material	WP	IBC	DIN	Price
IBCF60DINHM25-SS	SS 1.4404	16 bar	S60x6	DN25	
IBCF60DINHM32-SS	SS 1.4404	16 bar	S60x6	DN32	
IBCF60DINHM40-SS	SS 1.4404	16 bar	S60x6	DN40	
IBCF60DINHM50-SS	SS 1.4404	16 bar	S60x6	DN50	



IBC Innengewinde mit SMS 1145 Vaterteil

ohne Dichtung

IBC female thread with SMS 1145 male thread - without gasket

Taroudage femelle IBC avec filetage mâle SMS 1145 - sans joint

Adaptador rosca hembra IBC con macho SMS 1145 - sin junta

Gwint wewnętrzny IBC z gwintem zewnętrznym SMS 1145 - bez Uszczelka

Adattatore filettato femmina IBC con maschio SMS 1145 - senza guarnizione

Part-No.	Material	WP	IBC	SMS	Price
IBCF60SMSHM25-SS	SS 1.4404	16 bar	S60x6	DN25	
IBCF60SMSHM32-SS	SS 1.4404	16 bar	S60x6	DN32	
IBCF60SMSHM38-SS	SS 1.4404	16 bar	S60x6	DN38	
IBCF60SMSHM50-SS	SS 1.4404	16 bar	S60x6	DN50	



IBC Außengewinde mit SMS 1145 Vaterteil

IBC male thread with SMS 1145 male thread

Filetage mâle IBC avec filetage mâle SMS 1145

Adaptador macho IBC con macho SMS 1145

Gwint zewnętrzny IBC z gwintem zewnętrznym SMS 1145

Adattatore filettato maschio IBC con maschio SMS 1145



Part-No.	Material	WP	IBC	SMS	Price
IBCM60SMSTM25-SS	SS 1.4404	16 bar	S60x6	DN25	
IBCM60SMSTM32-SS	SS 1.4404	16 bar	S60x6	DN32	
IBCM60SMSTM38-SS	SS 1.4404	16 bar	S60x6	DN38	
IBCM60SMSTM50-SS	SS 1.4404	16 bar	S60x6	DN50	

IBC Innengewinde mit CLAMP DIN EN 32676 Kupplung

ohne Dichtung

IBC female thread with Clamp coupling - without gasket

Taroudage IBC femelle avec Raccord micro-CLAMP - sans joint

Adaptador rosca hembra IBC con Clamp - sin junta

Złącze IBC z gwintem wewnętrznym / Złącze «Clamp» - bez Uszczelka

Adattatore filettato femmina IBC con Clamp - senza guarnizione



Part-No.	Material	WP	IBC	Clamp	Price
IBCF60CLH051-SS	SS 1.4404	16 bar	S60x6	34	
IBCF60CLH106-SS	SS 1.4404	16 bar	S60x6	50,5	
IBCF60CLH206-SS	SS 1.4404	16 bar	S60x6	64	
IBCF60CLH256-SS	SS 1.4404	16 bar	S60x6	91	





IBC Innengewinde mit Anschweißende ohne Dichtung

IBC female thread with welding end -without gasket

Taraudage IBC femelle à souder - sans joint

Adaptador rosca hembra IBC para soldar - sin junta

Złącze IBC z gwintem wewnętrznym / Wtyk z końcówką do wspawania

Adattatore filettato femmina IBC a saldare - senza guarnizione

NEW

Part-No.	Material	WP	IBC	BW	Price
IBCF60BW20-SS	SS 1.4404	16 bar	S60x6	20x24	
IBCF60BW25-SS	SS 1.4404	16 bar	S60x6	26x29	
IBCF60BW32-SS	SS 1.4404	16 bar	S60x6	32x35	
IBCF60BW40-SS	SS 1.4404	16 bar	S60x6	38x41	
IBCF60BW50-SS	SS 1.4404	16 bar	S60x6	50x53	
IBCF60BW65-SS	SS 1.4404	16 bar	S60x6	66x70	
IBCF60BW80-SS	SS 1.4404	16 bar	S60x6	81x85	



IBC Außengewinde mit Anschweißende

IBC male thread with welding end

Filetage IBC mâle avec à souder

Adaptador rosca macho IBC para soldar

Gwint zewnętrzny IBC / Wtyk z końcówką do wspawania

Adattatore filettato maschio IBC a saldare

NEW

Part-No.	Material	WP	IBC	BW	Price
IBCM50BW20-SS	SS 1.4404	16 bar	S60x6	20x24	
IBCM60BW25-SS	SS 1.4404	16 bar	S60x6	26x29	
IBCM60BW32-SS	SS 1.4404	16 bar	S60x6	32x35	
IBCM60BW40-SS	SS 1.4404	16 bar	S60x6	38x41	
IBCM60BW50-SS	SS 1.4404	16 bar	S60x6	50x53	
IBCM60BW65-SS	SS 1.4404	16 bar	S60x6	66x70	
IBCM60BW80-SS	SS 1.4404	16 bar	S60x6	81x85	



Storz-Kupplung (DIN geschmiedet) mit IBC Innengewinde mit NBR Dichtung

Storz coupling - (DIN) with IBC female thread - NBR gasket

Raccord Storz taraudé IBC femelle - Joint NBR

Acople Storz (forjado) con rosca hembra IBC - Junta NBR

Złącze strażackie STORZ (DIN wykuty) z IBC gwintem wewnętrznym - NBR Uszczelka

Raccordo Storz (DIN forgiato) filettato IBC femmina - Guarnizione NBR



Part-No.	Material	WP	Storz	IBC	Price
ST52IBCF60DIN	Aluminum forged	16 bar	DN52(C)/66mm	S60x6	





IBC Innengewinde mit BSPP Innengewinde mit PE Weichdichtung

IBC female thread with BSPP female thread - PE foam gasket
 Taradage IBC femelle avec taradage BSPP femelle - Joint en mousse PE
 Acople rosca hembra IBC con rosca hembra BSPP - Junta de espuma PE
 Złącze IBC obustronnie z gwintem wewnętrznym - Uszczelka: polietylen małej gęstości
 Accoppiamento filettato femmina IBC con filetto femmina BSPP - Guarnizione di schiuma PE

Part-No.	Material	WP	IBC	Thread	Price
IBCF60BSPF050	Polypropylene	10 bar	S60x6	1/2"	
IBCF60BSPF075	Polypropylene	10 bar	S60x6	3/4"	
IBCF60BSPF100	Polypropylene	10 bar	S60x6	1"	
IBCF60BSPF150	Polypropylene	10 bar	S60x6	1 1/2"	
IBCF60BSPF200	Polypropylene	10 bar	S60x6	2"	



IBC Innengewinde mit drehbarem BSPP Innengewinde mit PE Weichdichtung

IBC female thread with swivel BSPP female thread - PE Foam Gasket
 Taradage IBC femelle avec taradage BSPP femelle (rotatif) - Joint en mousse PE
 Acople rosca hembra IBC con rosca hembra BSPP (giratorio) - Junta de espuma PE
 Złącze IBC obustronnie z gwintem wewnętrznym (obrotowo) - Uszczelka: polietylen małej gęstości
 Accoppiamento filettato femmina IBC con filetto femmina BSPP (girevole) - Guarnizione di schiuma PE

Part-No.	Material	WP	IBC	Thread	Price
IBCF60BSPF075-SW	Polypropylene	10 bar	S60x6	3/4"	



IBC Innengewinde mit IBC Außengewinde (45°) mit PE Weichdichtung

IBC female thread with IBC male thread (45°) - PE Foam gasket
 Taradage IBC femelle avec filetage IBC mâle (45°) - Joint en mousse PE
 Acople rosca hembra IBC con rosca macho IBC (45°) - Junta de espuma PE
 Złącze IBC z gwintem wewnętrznym i z gwintem zewnętrznym IBC (45°) - Uszczelka: polietylen małej gęstości
 Accoppiamento filettato femmina IBC con filetto maschio IBC (45°) - Guarnizione di schiuma PE

Part-No.	Material	Colour	WP	IBC	Price
IBCF100IBCM100-45W	Polypropylene	white	10 bar	S100x8	
IBCF60IBCM60-45	Polypropylene	black	10 bar	S60x6	
IBCF60IBCM60-45W	Polypropylene	white	10 bar	S60x6	



IBC Innengewinde mit BSPT Außengewinde

mit PE Weichdichtung

IBC female thread with BSPT male thread - PE foam gasket

Taraudage IBC femelle avec filetage BSPT mâle - Joint en mousse PE

Acople rosca hembra IBC con rosca macho BSPT - Junta de espuma PE

Złącze IBC z gwintem wewnętrznym i z gwintem zewnętrznym BSPT - Uszczelka: polietylen małej gęstości

Accoppiamento filettato femmina IBC con filetto maschio BSPT - Guarnizione di schiuma PE



Part-No.	Material	WP	IBC	Thread	Price
IBCF60BSPM075	Polypropylene	10 bar	S60x6	3/4"	
IBCF60BSPM100	Polypropylene	10 bar	S60x6	1"	
IBCF60BSPM150	Polypropylene	10 bar	S60x6	1 1/2"	
IBCF60BSPM200	Polypropylene	10 bar	S60x6	2"	
IBCF100BSPM200	Polypropylene	10 bar	S100x8	2"	

IBC Außengewinde mit Innengewinde

mit PE Weichdichtung

IBC male thread with female thread - PE foam gasket

Filetage IBC mâle avec taraudage femelle - Joint en mousse PE

Acople rosca macho IBC con rosca hembra - Junta de espuma PE

Złącze IBC z gwintem zewnętrznym i z gwintem wewnętrznym - Uszczelka: polietylen małej gęstości

Accoppiamento filettato maschio IBC con filetto femmina - Guarnizione PE



Part-No.	Material	WP	IBC	Thread	Price
IBCM60BSPF200	Polypropylene	10 bar	S60x6	2" BSPP	
IBCM60IBCKF80	Polypropylene	10 bar	S60x6	M80x3	

IBC Außengewinde mit BSPT Außengewinde

IBC male thread with BSPT male thread

Filetage IBC mâle avec filetage BSPT mâle

Adaptador rosca macho IBC con rosca macho BSPT

Złącze IBC z gwintem zewnętrznym i z gwintem zewnętrznym BSPT

Accoppiamento filettato maschio IBC con filetto maschio BSPT



Part-No.	Material	WP	IBC	Thread	Price
IBCM60BSPM200	Polypropylene	10 bar	S60x6	2"	





IBC Innengewinde mit gerilltem Stutzen

mit PE Weichdichtung

IBC female thread with serrated hose shank - PE foam gasket

Taraudage IBC femelle avec douille annelée - Joint en mousse PE

Acople rosca hembra IBC con espiga dentada - Junta de espuma PE

Złącze IBC z gwintem wewnętrznym/z karbowaną końcówką do węża - Uszczelka: polietylen małej gęstości

Accoppiamento filettato femmina IBC con portagomma a resca - Guarnizione di schiuma PE

Part-No.	Material	WP	IBC	Shank	Price
IBCF60HT050	Polypropylene	10 bar	S60x6	DN15	
IBCF60HT075	Polypropylene	10 bar	S60x6	DN19	
IBCF60HT100	Polypropylene	10 bar	S60x6	DN25	
IBCF60HT125	Polypropylene	10 bar	S60x6	DN32	
IBCF60HT150	Polypropylene	10 bar	S60x6	DN38	
IBCF60HT200	Polypropylene	10 bar	S60x6	DN50	



IBC Innengewinde mit drehbarem, gerilltem Stutzen

mit PE Weichdichtung

IBC female thread with swivel hose shank - PE foam gasket

Taraudage IBC femelle rotatif avec douille annelée - Joint en mousse PE

Acople rosca hembra IBC con espiga dentada giratoria - Junta de espuma PE

Złącze IBC z gwintem wewnętrznym/z obrotową karbowaną końcówką do węża - Uszczelka: polietylen małej gęstości

Accoppiamento filettato IBC con portagomma girevole - Guarnizione di schiuma PE

Part-No.	Material	WP	IBC	Shank	Price
IBCF60HT075-SW	Polypropylene	10 bar	S60x6	DN19	
IBCF60HT100-SW	Polypropylene	10 bar	S60x6	DN25	
IBCF60HT125-SW	Polypropylene	10 bar	S60x6	DN32	
IBCF60HT150-SW	Polypropylene	10 bar	S60x6	DN38	
IBCF60HT200-SW	Polypropylene	10 bar	S60x6	DN50	



IBC Außengewinde mit gerilltem Stutzen

IBC male thread with serrated hose shank
 Filetage IBC mâle avec douille annelée
 Acople rosca macho IBC con espiga dentada
 Złącze IBC z gwintem zewnętrznym/z karbowaną końcówką do węży
 Accoppiamento filettato maschio IBC con portagomma a resca

Part-No.	Material	WP	IBC	Shank	Price
IBCM60HT200	Polypropylene	10 bar	S60x6	DN50	

**IBC Reduzierung**

mit PE Weichdichtung

IBC Reducer - PE foam gasket
 Réduction IBC - Joint en mousse PE
 Reducción IBC - Junta de espuma PE
 Złącze IBC Redukcja - Uszczelka: polietylen małej gęstości
 Riduzione IBC - Guarnizione di schiuma PE

Part-No.	Material	WP	IBC	IBC	Price
IBCF100IBCM60	Polypropylene	10 bar	S100x8	S60x6	

**IBC Innengewinde mit Kamlok Vaterteil**

mit PE Weichdichtung

IBC female thread with C&G male type A - PE foam gasket
 Taraudage IBC femelle avec adaptateur type A - Joint en mousse PE
 Acople rosca hembra IBC con Camlock macho tipo A - Junta de espuma PE
 Złącze IBC z gwintem wewnętrznym/Wtyk CAMLOCK typ A - Uszczelka: polietylen małej gęstości
 Accoppiamento filettato femmina IBC con camlock maschio tipo A - Guarnizione di schiuma PE

Part-No.	Material	WP	IBC	C&G	Price
IBCF60A100	Polypropylene	10 bar	S60x6	1"	
IBCF60A150	Polypropylene	10 bar	S60x6	1 1/2"	
IBCF60A200	Polypropylene	10 bar	S60x6	2"	
IBCF100A200	Polypropylene	10 bar	S100x8	2"	





Übergangsstück Kamlok Mutterteil auf IBC- Kupplung AG

Adapter camlock female type to IBC buttress couplings male thread

Adaptateur à cames femelle sur raccord IBC fileté mâle

Adaptador camlock hembra con rosca macho IBC

Złącze IBC do paletopojemników z gwintem zewnętrznym/Wtyk CAMLOCK typ B

Adattatore camlock femmina con filettato maschio IBC

Part-No.	Material	WP	C&G	IBC	Price
IBCM60B200	Polypropylene	10 bar	DN50	S60x6	

IBC Kappe

IBC Cap

Bouchon IBC

Tapones IBC

IBC Pokrywka

Tappo IBC



Part-No.	Colour	Material	Thread	Description	Price
IBCC155	Black	Polypropylene	DN150		
IBCC155-2	Red	Polypropylene	DN150	with vent	
IBCC225	Black	Polypropylene	DN200		
IBCC225-2	Red	Polypropylene	DN200	with vent	
IBCC60	Black	Polypropylene	S60x6		
IBCC60-2	Black/Red	Polypropylene	S60x6	with removable cap	

IBC Containerplane

IBC protective cover

Housse de protection IBC

Funda protectora IBC

okładka IBC

Copertura protettiva per IBC



Part-No.	Colour	Material	Description	Price
IBCCOVER1	green	PE	without zipper	
IBCCOVER2	black	LDPE	without zipper	
IBCCOVER3	Black	420 oxford	with zipper	



IBC Auslaufhahn ohne Verschluss

IBC outlet tap without closure
 Robinet de vidange IBC sans bouchon
 IBC salida en codo sin cierre
 Zawór wylotowy IBC bez zamknięcia
 Becucuccio di scarico per IBC senza chiusura



Part-No.	Colour	Material	Price
IBCPPIPE-B	Black	Polypropylene	
IBCPPIPE-W	White	Polypropylene	

Zapfpistole mit Schlauch

Nozzle PP with hose
 Pistolet de distribution PP avec tuyau
 Boquerel de PP con manguera
 Dysza PP z wężem
 Pistola di riempimento in PP con tubo flessibile



Part-No.	Hose	WP	Side 1	Side 2	Price
NZS075IBCF60-2M	PVC black, 2 m	5 bar	white PP Nozzle Outlet 3/4" in SS304	IBC S60X6 female thread, black	

10 bar Platzdruck
 10 bar burst pressure

Auslaufhahn mit IBC Innengewinde

mit PE Weichdichtung

S60x6 female IBC thread, tap - PE foam gasket
 IBC taraudé femelle - Joint en mousse PE
 Rosca hembra IBC a grifo - Junta de espuma PE
 Złącze IBC z gwintem wewnętrznym z - Uszczelka: polietylen małej gęstości
 Filettatura femmina IBC - Guarnizione schiuma PE



Part-No.	Material	Description	IBC Female	Price
IBCF60TAP	Polypropylene	with QuickConnector	S60x6	
IBCF60TAP-W	Polypropylene	without Quick Connector	S60x6	
IBCF60TAP-3	Polypropylene	with 16mm Shank	S60x6	





IBC Schlüssel

IBC spanner
Clé pour IBC
Llave plana IBC
IBC Klucz montażowy
IBC chiave piatta

Part-No.	Colour	Material	Price
IBCS-S	Black	ABS	



IBC 2" Kugelhahn mit Gewindedeckel

IBC 2" ball-valves
IBC 2" vanne à boule
Válvula de bola IBC 2"
Złącze IBC 2" Zawory kulowe
Valvola a sfera IBC 2"



Part-No.	Colour	Material	Gasket	Female	Thead	Handle	Price
IBCBT60	White	PP		S60x6	IBC S60x6	Blue	
IBCBVM60-E	Black	PP	EPDM	S75x6 with EPDM	IBC S60x6	Red	
IBCBVM60-P	Black	PP	PTFE	S75x6 with EPDM	IBC S60x6	Red	
IBCBVM60-V	Black	PP	FKM	S75x6 with FKM	IBC S60x6	Blue	
IBCBVNPTM50-P	Black	PP	PTFE	S75x6 with EPDM	NPT DN50	Yellow	

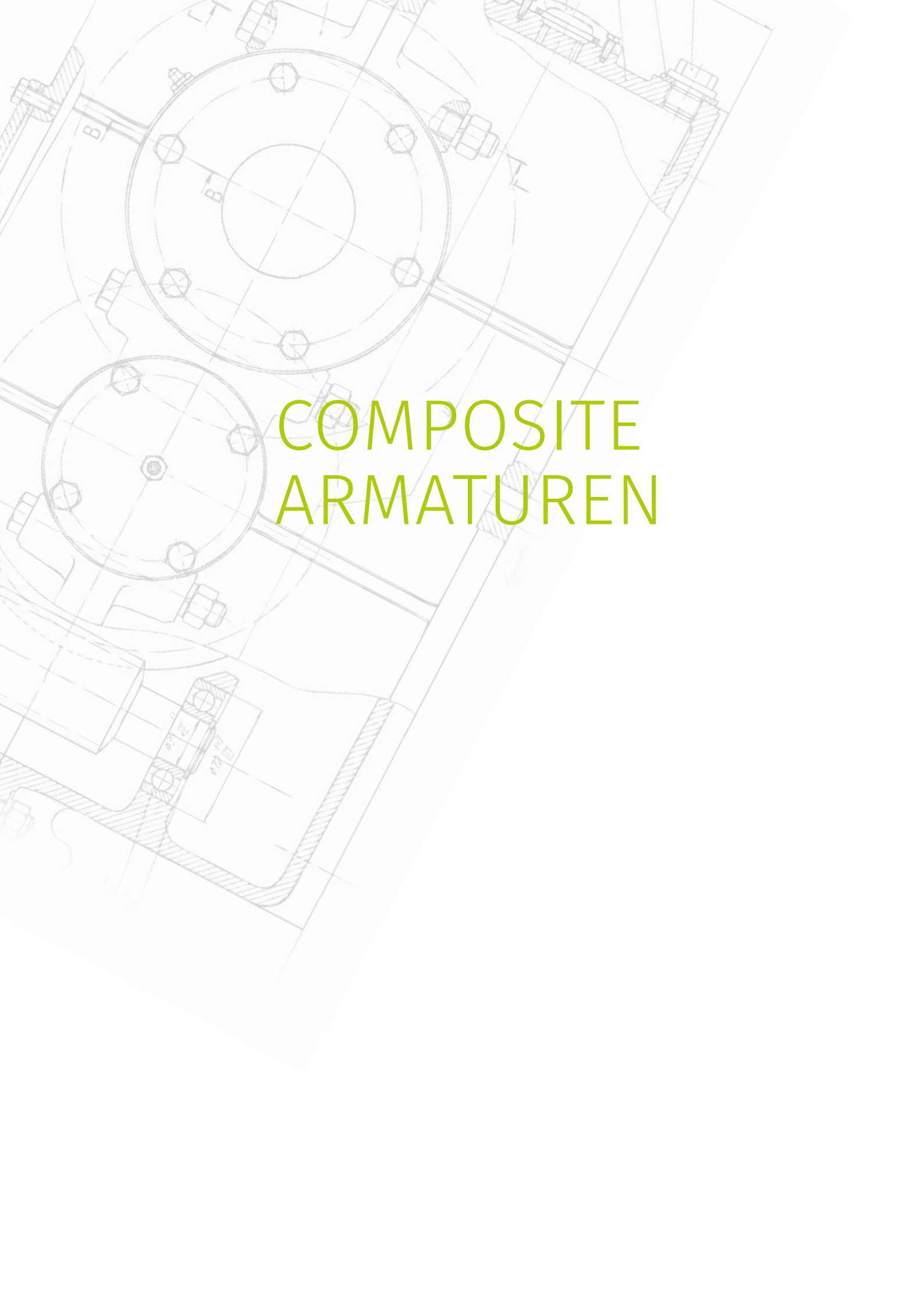

A technical drawing of composite armatures, showing two circular components with multiple bolts around their perimeters. The drawing includes various views and details, such as a cross-section of a bolted joint and a detail of a bolted connection. The text 'COMPOSITE ARMATUREN' is overlaid in the center in a bold, yellow font. The drawing is rendered in a light gray color on a white background.

COMPOSITE ARMATUREN

INFORMATIONEN

Composite Armaturen



Armaturen für Folienwickelschläuche werden in den Schlauch hineingeschraubt und nicht hineingesteckt. Auf die Spiralsteigung der Innenspirale muss das Gewinde des Fittings angepasst sein. Nur so ist die Verdreh- und Ausreissfestigkeit nach der Verpressung gegeben. Wichtig ist daher eine Übereinstimmung der Spiralsteigung mit der

Fittingsteigung, um einen genauen Sitz des Fittings im Schlauch zu erhalten.

Auch sollte die Fassungskontur mit der Kontur der Dichtung passend sein, um eine optimale Dichtigkeit zu erzielen.

Die Dichtung darf nicht unter dem Einfluss der Chemikalien quellen, um eine dauerhafte Dichtigkeit zu erzielen.

Das Einbinden von Folienwickelschläuchen mit der Armatur erfordert Übung. Wichtig ist, dass die Spirale vor dem Dichtbereich abgeschnitten wird. Außer Öl- oder Anwendungen mit Kohlenwasserstoffen sollte die FKM-Dichtung verwendet werden.

WARUM MCC?

- Die Armaturen sind im Dichtbereich spanend überarbeitet und haben eine hohe Oberflächengüte und die Dichtung Innenseite ist genau darauf angepasst.
- Der Gewindebereich der Kupplung ist angeraut, um einen besseren Kontakt zur Metallspirale zu erzielen, was die Verdreh Sicherheit erhöht.
- Bei MCC-Armaturen kann das Abtrennen der inneren Spirale genau abgemessen werden, da der Übergang zur Dichtfläche klar abgegrenzt ist.
- Die Fassungen/Presshülse und Elastomerdichtungen sind in der Kontur aufeinander abgestimmt
- Die Dichtungen sind in NBR und FKM-Qualität und im Quellverhalten optimiert.
- Armaturen und Fassungen in Aluminium zur Gewichtseinsparung und Rostfreiheit.



TECHNISCHE INFORMATIONEN

- Schlauchnorm DIN EN 13765
- Steigung der Armaturen ??mm
- Werkstoffe:
Armaturen: Edelstahl, Aluminium und PP
Kupplungsdichtung: NBR, FKM
- Aluminium nicht in Ex Zonen einsetzen, da Aluminium zur Funkenbildung neigt.
- Anschlussgewinde nach ISO 288 und stirnseitig flachdichtend
- Nennweiten von 1 1/2" bis 4"

EINSATZGEBIET

Folienwickelschlauchleitungen sind bei Be- und Entladevorgängen sehr beliebt. Sie sind häufiger in großen Nennweiten über 2" zu finden. Sie sind kälteflexibel, haben geringste Biegeradien und sind leicht zu händeln. Darüber hinaus sind Folienwickelschläuche sehr robust und nahezu unverwüsthlich.

Sie sind durch ihren Aufbau schlecht von innen zu reinigen, so dass dieses bei Wechsel der Fluide zu berücksichtigen ist.

BSP Außengewinde (auch mit Guillemin erhältlich)

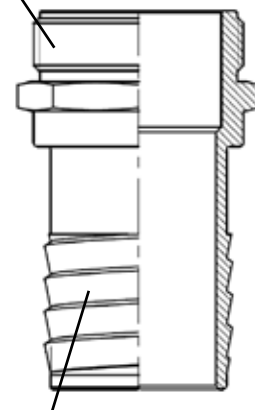

Schlauchstutzen - 1 Spirale



INFORMATION

Composite Couplings

Composite hose couplings are hose and not pushed in. The separation pitch of the hose shank must be adapted to the inner helix of composite hose.

This is the only way to ensure resistance to twisting and tearing after crimping. It is therefore important that the spiral pitch matches the

fitting pitch in order to obtain an exact fit of the fitting in the hose.

The contour of the fitting should also match the contour of the seal in order to achieve optimum tightness.

The seal must not swell under the influence of chemicals in order to achieve a permanent seal.

It takes practice to assemble the Composite Hose with the Helico Couplings. It is important that the spiral is cut off before the sealing area. Except for oil or hydrocarbon applications, the FKM gasket should be used.

WHY MCC?

- The fittings are machined in the gasket area and have a high surface quality and the seal on the inside is precisely adapted to this.
- The threaded area of the coupling is roughened to achieve better contact with the metal spiral, which increases the torsional safety..
- With MCC fittings, the separation of the inner spiral can be precisely measured, as the transition to the sealing surface is clearly defined.
- The contours of the sockets/pressing sleeve and elastomer seals are matched to each other
- The gasket are in NBR and FKM quality and optimized for swelling behaviour.
- Fittings and sockets in aluminum to reduce weight and prevent rust.



TECHNICAL INFORMATION

- Hose standard DIN EN 13765
- Pitch of the couplings 22mm
- Material:
Couplings: stainless steel, aluminum, polypropylen
Gasket: NBR, FKM
- Do not use aluminum in Ex zones, as aluminum tends to spark.
- Connection thread to ISO 288 and flat sealing on the end face
- Size from 1 1/2" to 4"

AREA OF APPLICATION

Foil-wound hose lines are very popular for loading and unloading processes. They are more frequently found in large nominal widths over 2". They are flexible at low temperatures, have very small bending radii and are easy to handle. In addition, film wrap hoses are very robust and virtually indestructible.

BSP male thread (also with guillemin available)

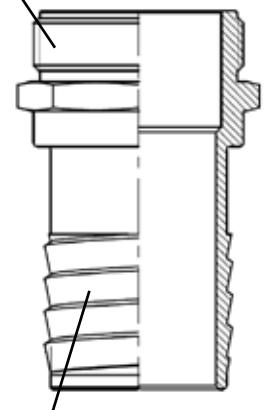

Hose shank - 1 helico



Guillemin Kupplung mit Einpresstutzen für Folienwickelschläuche
mit Presshülse & NBR Dichtung (SET)

Guillemin coupling with helico shank for composite hose with Ferrule & NBR gasket (set)
Raccord Guillemin à douille hélicoïdale pour tuyau composite avec jupe et joint NBR (Set)
Guillemin con espiga helicoidal para manguera composite - con campana y junta NBR (set completo)
Złącze Guillemin do węzła kompozytowego pod tuleję zaciskową z Tuleja zaciskowa i NBR uszczelka (ustawić)
Guillemin con portagomma elicoidale per tubo composite - con boccola e guarnizione NBR (set completo)



Part-No.	for Helices	Material	WP	Dimension	Shank	Price
GST150SSC	1	SS 1.4408	14 bar	DN38	1 1/2"	
GST200SSC	1	SS 1.4408	14 bar	DN50	2"	
GST250SSC	1	SS 1.4408	14 bar	DN65	2 1/2"	
GST300SSC	1	SS 1.4408	14 bar	DN80	3"	
GST400SSC	1	SS 1.4408	14 bar	DN100	4"	



Guillemin Kupplung mit Einpresstutzen für Folienwickelschläuche

Guillemin coupling with helico shank for composite hose
Raccord Guillemin à douille hélicoïdale pour tuyau composite
Guillemin con espiga helicoidal para mangueras composite
Złącze Guillemin do węzła kompozytowego pod tuleję zaciskową
Guillemin con portagomma elicoidale per tubo composite

Part-No.	for Helices	Material	WP	Dimension	Shank	Price
GST150SS	1	SS 1.4408	14 bar	DN38	1 1/2"	
GST200SS	1	SS 1.4408	14 bar	DN50	2"	
GST250SS	1	SS 1.4408	14 bar	DN65	2 1/2"	
GST300SS	1	SS 1.4408	14 bar	DN80	3"	
GST400SS	1	SS 1.4408	14 bar	DN100	4"	

COMPOSITE



Guillemin Kupplung mit Einpressstutzen für Folienwickelschläuche

abschließbar mit Arretierung

Guillemin coupling with helico shank for composite hose - Lockable with extra lock

Raccord Guillemin à douille hélicoïdale pour tuyau composite - avec serrure supplémentaire

Guillemin con espiga helicoidal para manguera composite - se puede bloquear con una cerradura adicional

Złącze Guillemin do węża kompozytowego pod tuleję zaciskową - dodatkowy zamek

Guillemin con portagomma elicoidale per tubo composite - con lucchetto aggiuntivo



NEW

Part-No.	for Helices	Material	WP	Dimension	Shank	Price
GST300SS-H	1	SS 1.4408	14 bar	DN80	3"	

Guillemin Kupplung mit Einpressstutzen für Folienwickelschläuche

PFA ausgekleidet

Guillemin coupling with helico shank for composite hose - PFA coated

Raccord Guillemin à douille hélicoïdale pour tuyau composite - Revêtu de PFA

Guillemin con espiga helicoidal recubierta en PFA para manguera composite

Złącze Guillemin do węża kompozytowego pod tuleję zaciskową - Z powłoką PFA

Guillemin con portagomma elicoidale con rivestimento in PFA per tubo composite

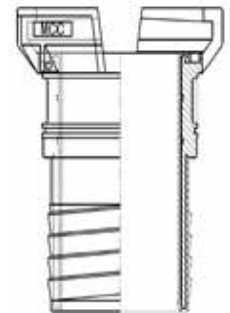

COMPOSITE

NEW

Part-No.	Material	WP	Dimension	Shank	Price
GST200SSPFA-B	SS 1.4408 PFA black coated	14 bar	DN50	50mm	
GST300SSPFA-B	SS 1.4408 PFA black coated	14 bar	DN80	76mm	
GST400SSPFA-B	SS 1.4408 PFA black coated	14 bar	DN100	100mm	



Einpressstutzen mit BSP AG für Folienwickelschläuche

mit Presshülse & NBR Dichtung (SET)



Male thread with helico shank for composite hose with Ferrule & NBR gasket (set)

Raccord mâle BSP à douille hélicoïdale pour tuyau composite avec jupe et joint NBR (Set)

Rosca macho con espiga helicoidal para manguera composite - con campana y junta NBR (set completo)

Złącze zaciskowe do węża kompozytowego z gwintem zewnętrznym BSP z tuleja zaciskowa i NBR uszczelka (ustawić)

Accoppiamento filettatura maschio con portagomma elicoidale per tubo composite - con boccola e guarnizione NBR (set completo)

Part-No.	for Helices	Material	WP	Dimension	Shank	Price
HST150SSC	1	SS 316	14 bar	DN38	1 1/2"	
HST200SSC	1	SS 316	14 bar	DN50	2"	
HST250SSC	1	SS 316	14 bar	DN65	2 1/2"	
HST300SSC	1	SS 316	14 bar	DN80	3"	
HST400SSC	1	SS 316	14 bar	DN100	4"	

Einpressstutzen mit BSP AG für Folienwickelschläuche

Male thread with helico shank for composite hose

Raccord mâle BSP à douille hélicoïdale pour tuyau composite

Rosca macho con espiga helicoidal para manguera composite

Złącze zaciskowe do węża kompozytowego z gwintem zewnętrznym BSP z

Accoppiamento filettatura maschio con portagomma elicoidale per tubo composite



Part-No.	for Helices	Material	WP	Dimension	Shank	Price
HST150SS	1	SS 316	14 bar	DN38	1 1/2"	
HST200SS	1	SS 316	14 bar	DN50	2"	
HST250SS	1	SS 316	14 bar	DN65	2 1/2"	
HST300SS	1	SS 316	14 bar	DN80	3"	
HST400SS	1	SS 316	14 bar	DN100	4"	



Einpressstutzen mit BSP AG für Folienwickelschläuche

PFA ausgekleidet

Male thread with helico shank for composite hose - PFA coated

Raccord mâle BSP à douille hélicoïdale pour tuyau composite - Revêtu de PFA

Rosca macho con espiga helicoidal recubierta en PFA para manguera composite

Złącze zaciskowe do węzła kompozytowego z gwintem zewnętrznym BSP z - z powłoką PFA

Accoppiamento filettatura maschio con portagomma elicoidale con rivestimento in PFA per tubo composite



NEW

Part-No.	Material	WP	Dimension	Shank	Price
HST150SSPFA-B	SS 1.4408 PFA black coated	14 bar	DN40	40mm	
HST200SSPFA-B	SS 1.4408 PFA black coated	14 bar	DN50	50mm	
HST300SSPFA-B	SS 1.4408 PFA black coated	14 bar	DN80	76mm	
HST400SSPFA-B	SS 1.4408 PFA black coated	14 bar	DN100	100mm	



Presshülse gebördelt

Stamped ferrule

Jupe emboutie

Campana de prensado

Tuleja zaciskowa

Boccole a pressare



Part-No.	Material	WP	Dimenion	Int * LG * DP	Price
SSE150	SS 304	6 bar	DN38	57 * 56 * 44,5	
SSE2	SS 304	6 bar	DN50	72 * 66,5 * 55	
SSE250	SS 304	6 bar	DN65	85 * 82 * 68,3	
SSE3	SS 304	6 bar	DN80	98 * 85 * 83	
SSE4	SS 304	6 bar	DN100	123 * 100 * 105,5	

COMPOSITE



GST...AL



Guillemin Kupplung mit Einpresstutzen für Folienwickelschläuche
mit Presshülse & NBR Dichtung (SET)

Guillemin coupling with helico shank for composite hose with Ferrule & NBR gasket (set)

Raccord Guillemin à douille hélicoïdale pour tuyau composite avec jupe et joint NBR (Set)

Guillemin con espiga helicoidal para manguera composite - con campana y junta NBR (set completo)

Złącze Guillemin do węza kompozytowego pod tuleję zaciskową z Tuleja zaciskowa i NBR uszczelka (ustawić)

Guillemin con portagomma elicoidale per tubo composite - con boccola e guarnizione NBR (set completo)

ASE...



JH...

Part-No.	for Helices	Material	WP	Dimension	Shank	Price
GST150ALC	1	Aluminum	14 bar	DN38	1 1/2"	
GST200ALC	1	Aluminum	14 bar	DN50	2"	
GST250ALC	1	Aluminum	14 bar	DN65	2 1/2"	
GST300ALC	1	Aluminum	14 bar	DN80	3"	
GST400ALC	1	Aluminum	14 bar	DN100	4"	

COMPOSITE



Guillemin Kupplung mit Einpresstutzen für Folienwickelschläuche

Guillemin coupling with helico shank for composite hose

Raccord Guillemin à douille hélicoïdale pour tuyau composite

Guillemin con espiga helicoidal para manguera composite

Złącze Guillemin do węza kompozytowego pod tuleję zaciskową

Guillemin con portagomma elicoidale per tubo composite

Part-No.	for Helices	Material	WP	Dimension	Shank	Price
GST150AL	1	Aluminum	14 bar	DN38	1 1/2"	
GST200AL	1	Aluminum	14 bar	DN50	2"	
GST250AL	1	Aluminum	14 bar	DN65	2 1/2"	
GST300AL	1	Aluminum	14 bar	DN80	3"	
GST400AL	1	Aluminum	14 bar	DN100	4"	



Einpressstutzen mit BSP AG für Folienwickelschläuche

mit Presshülse & NBR Dichtung (SET)

Male thread with helico shank for composite hose with Ferrule & NBR gasket (set)

Raccord mâle BSP à douille hélicoïdale pour tuyau composite avec jupe et joint NBR (Set)

Rosca macho con espiga helicoidal para manguera composite - con campana y junta NBR (set completo)

Złącze zaciskowe do węża kompozytowego z gwintem zewnętrznym BSP z tuleja zaciskowa i NBR uszczelka (ustawić)

Accoppiamento filettatura maschio con portagomma elicoidale per tubo composite - con boccola a pressare e NBR guarnizione (set completo)

Part-No.	for Helices	Material	WP	Dimension	Shank	Price
HST150ALC	1	Aluminum	14 bar	DN38	1 1/2"	
HST200ALC	1	Aluminum	14 bar	DN50	2"	
HST250ALC	1	Aluminum	14 bar	DN65	2 1/2"	
HST300ALC	1	Aluminum	14 bar	DN80	3"	
HST400ALC	1	Aluminum	14 bar	DN100	4"	

**Einpressstutzen mit BSP AG für Folienwickelschläuche**

Male Thread with helico shank for composite hose

Raccord mâle BSP à douille hélicoïdale pour tuyau composite

Rosca macho con espiga helicoidal para manguera composite

Złącze zaciskowe do węża kompozytowego z gwintem zewnętrznym BSP z

Accoppiamento filettatura maschio con portagomma elicoidale per tubo composite



Part-No.	for Helices	Material	WP	Dimension	Shank	Price
HST150AL	1	Aluminum	14 bar	DN38	1 1/2"	
HST200AL	1	Aluminum	14 bar	DN50	2"	
HST250AL	1	Aluminum	14 bar	DN65	2 1/2"	
HST300AL	1	Aluminum	14 bar	DN80	3"	
HST400AL	1	Aluminum	14 bar	DN100	4"	



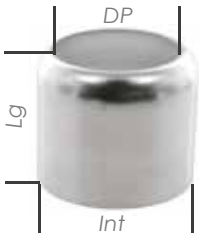

Presshülse gebördelt

Stamped ferrule
 Jupe emboutie
 Campana de prensado
 Tuleja zaciskowa
 Boccole a pressare

Part-No.	Material	WP	Dimension	Int * LG * DP	Price
ASE150	Aluminium	6 bar	DN38	57 * 56 * 44,5	
ASE2	Aluminium	6 bar	DN50	72 * 66,5 * 55	
ASE250	Aluminium	6 bar	DN65	85 * 82 * 68,3	
ASE3	Aluminium	6 bar	DN80	98 * 85 * 83	
ASE4	Aluminium	6 bar	DN100	123 * 100 * 105,5	

COMPOSITE



Einpressstutzen mit BSP AG für Folienwickelschläuche

Male thread with helico shank for composite hose
 Raccord mâle BSP à douille hélicoïdale pour tuyau composite
 Rosca macho con espiga helicoidal para manguera composite
 Złącze zaciskowe do węża kompozytowego z gwintem zewnętrznym BSP z
 Accoppiamento filettatura maschio con portagomma elicoidale per tubo composite

Part-No.	for Helices	Material	WP	Dimension	Shank	Price
HST200PP	1	Polypropylen	14 bar	DN50	2"	
HST300PP	1	Polypropylen	14 bar	DN80	3"	



A detailed technical drawing of a PFA-lined valve assembly. The drawing shows a cross-section of the valve body, which is lined with PFA (perfluoroalkoxy). The valve is equipped with a handwheel and a stem. The drawing includes various dimensions and labels, such as 'B' and 'H1', indicating specific parts and measurements. The text 'PFA AUSGEKLEIDETE ARMATUREN' is overlaid on the drawing in a purple font.

PFA AUSGEKLEIDETE ARMATUREN

INFORMATIONEN

PFA ausgekleidete Armaturen



PFA (Perfluoralkoxy) überzeugt durch eine gute chemische Beständigkeit, die der von PTFE oder ECTFE entspricht. Es bietet jedoch gegenüber diesen Werkstoffen eine Vielzahl von Vorteilen. So hat PFA eine außergewöhnliche Temperaturbeständigkeit im Bereich von -220 °C bis $+260\text{ °C}$. Zudem ist es vollständig frei von Verarbeitungshilfsstoffen,

wodurch die Reinheit hochsensibler Fluide gewährleistet wird. Dieses Material ist besonders geeignet für Einsatzbereiche, in denen selbst Edelstahl angegriffen wird, beispielsweise beim Kontakt mit Eisen (III)-Chlorid. Daher ist die dauerhaft feste Haftung der PFA-Auskleidung an dem stabilen

Edelstahlkern ein wichtiges Qualitätsmerkmal. Die MCC-Armaturen weisen zudem eine deutlich dickere PFA-Auskleidung von bis zu 3mm auf. Diese Eigenschaften machen unsere Armaturen zur optimalen Wahl für anspruchsvolle Anwendungen, die Festigkeit und Langlebigkeit erfordern.

WARUM MCC?

- PFA Schichtdicke von 1mm-3mm
- PFA weiß in hoher Wanddicke verfügbar (diffusionsdicht)
- Diverse Zulassungen für Lebensmittel und Pharma
- Auch in Ω -Ausführung mit $R < 106\ \Omega$ verfügbar
- Rippenstützen nach DIN EN 14420
- Als Sonderanfertigung sind auch andere Kupplungs-Typen mit einer PFA-Auskleidung herstellbar.



TECHNISCHE INFORMATIONEN

- a. Hochreines PFA
- b. Schichtdicke $>1\text{mm}$ bis 3mm
- c. Schwarzes PFA $<10^6\ \Omega$
- d. Vakuum fest, Temperaturbeständig bis 200 °C

EINSATZGEBIET

Hochreine Fluide
Kunststoffbeschichtung für hohe Temperaturen

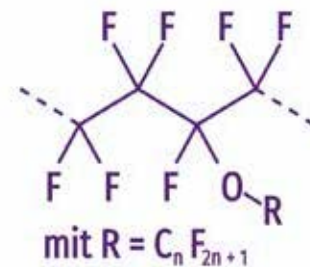

PFA= Fluorketten mit einer Oxydgruppe, die die Diffusionsdichtigkeit gegenüber PTFE drastisch erhöht



INFORMATION

PFA lined fittings

PFA (perfluoroalkoxy) impresses with its good chemical resistance, which corresponds to that of PTFE or ECTFE. However, it offers a number of advantages over these materials. For example, PFA has exceptional temperature resistance in the range from -220 °C to +260 °C. It is also completely free of processing aids, which guarantees the purity of

highly sensitive fluids. This material is particularly suitable for applications in which even stainless steel is attacked, for example when in contact with iron (III) chloride. Therefore, the permanent adhesion of the PFA lining to the stable stainless steel core is an important quality feature.

The MCC couplings also have a significantly thicker PFA lining of up to 3 mm. These properties make our fittings the ideal choice for demanding applications that require strength and durability.

WHY MCC?

- PFA layer thickness from 1mm-3mm
- PFA white available in high wall thickness (diffusion-tight)
- Various approvals for food and pharmaceuticals
- Also available in Ω version with $R < 106 \Omega$
- Ribbed spigot according to DIN EN 14420
- Other coupling types with a PFA lining can also be manufactured as special designs.



TECHNICAL INFORMATION

- High purity PFA
- Layer thickness >1mm to 3mm
- Black PFA $< 10^6 \Omega$ (conductive)
- Usable for vacuum, temperature range up to 200 °C

AREA OF APPLICATION

Almost universal fitting in the chemical and food industry. It is mainly used in France and can be used in addition to the milk pipe fitting to avoid confusion.

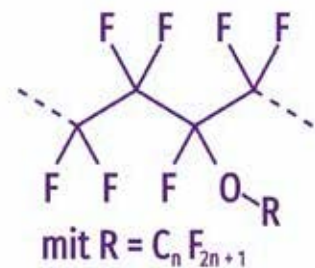

PFA= fluorine chains with an oxide group, which drastically increases the diffusion tightness compared to PTFE

INFORMATIONEN

PFA ausgekleidete Armaturen



ALLGEMEINE EIGENSCHAFTEN PFA

	Eigenschaften	Spezifikation	Einheit	Wert
Allgemein	Dauerbetriebstemperatur	Maximum	°C	260
	Chemische Beständigkeit		-	Ausgezeichnet
	Spezifische Schwerkraft	D 792	g/cm ³	2.15
Elektrisch	Dielektrische Konstante	D150 at 10 ³ Hz	-	2.04
		D150 at 10 ³ Hz		2.04
	Dielektrischer Verlustfaktor	D150 at 10 ³ Hz		0.0002
		D150 at 10 ³ Hz		0.0003
	Durchschlagskraft	D 149	kV/mm	55
	Durchschlagswiderstand	D 257	Ohm*cm	>1018
Mechanisch	Zugfestigkeit	D 1708, D638	Mpa	30
	Dehnung	D 1708 D638	%	300
	Druckfestigkeit	D 695	Mpa	15
	Schlagfestigkeit	D 256 bij +23°C	J/m	kein Bruch
	Biegemodus	D 790 bij +23°C	Mpa	690
	Zugwiderstand	D 638	Mpa	270
	Härte	D 2240	-	60-65
Thermisch	Schmelzpunkt		°C	305
	Wärmeleitfähigkeit	+23°C	W/Kg.m	0.25
	HDT	DIN 75	°C	
	Verfahren A			74
	Verfahren B			48

ALLGEMEINES ZUR PFA BESCHICHTUNG

Artikel-Nr.	Betriebstemperatur	Betriebsdruck	Dicke	Farbe
LNC	(-)50°C ~ 200°C	PN25	≥ 2mm	Weiß/Schwarz leitend
DIN32676 Kuplungen	(-)50°C ~ 200°C	PN16	2mm	Weiß/Schwarz leitend
MK und VK	(-)50°C ~ 200°C	PN25	2mm	Weiß/Schwarz leitend
DIN11851 Kuplungen	(-)50°C ~ 200°C	PN16	≥ 2mm	Weiß/Schwarz leitend
Macon Kuplungen	(-)50°C ~ 200°C	PN16	≥ 2mm	Weiß/Schwarz leitend
SS Kamlock	(-)50°C ~ 200°C	PN25	≥ 2mm	Weiß/Schwarz leitend
Flansche	(-)50°C ~ 200°C	PN16	≥ 2mm	Weiß/Schwarz leitend
Guillemin	(-)50°C ~ 200°C	PN16	≥ 2mm	Weiß/Schwarz leitend
Composite	(-)50°C ~ 200°C	PN14	≥ 2mm	Schwarz leitend

ANMERKUNG

Leitfähigkeit schwarzer beschichtet: 10³ ~ 10⁵ Ω

Bei anderen Artikeln mit größeren Abmessungen, wie z.B. 3", beträgt die PFA-Dicke etwa 2,5-3mm.

Für die DIN32676-Kupplung beträgt die PFA-Dicke für die Scheibe 1 mm aufgrund der Begrenzung der Standardabmessungen.



INFORMATION

PFA lined fittings

GENERAL INFORMATION PFA

	Property	Specification	Unit	Value
General	Continuous working temp.	Maximum	°C	260
	Chemical resistance		-	Excellent
	Specific gravity	D 792	g/cm ³	2.15
Electrical	Dielectric constant	D150 at 10 ³ Hz	-	2.04
		D150 at 10 ³ Hz		2.04
	Dielectric dissipation factor	D150 at 10 ³ Hz		0.0002
		D150 at 10 ³ Hz		0.0003
	Dielectric strength	D 149	kV/mm	55
	Volume resistivity	D 257	Ohm*cm	>1018
Mechanical	Tensile strength	D 1708, D638	Mpa	30
	Elongation	D 1708 D638	%	300
	Compressive strength	D 695	Mpa	15
	Impact strength	D 256 bij +23°C	J/m	No break
	Flexural Modulus	D 790 bij +23°C	Mpa	690
	Tensile Modulus	D 638	Mpa	270
	Hardness	D 2240	-	60-65
Thermal	Melting point		°C	305
	Thermal conductivity	+23°C	W/Kg.m	0.25
	HDT	DIN 75	°C	
	method A			74
	method B			48

GENERAL INFORMATION PFA COATING

Items	Working temperature	Working pressure	Thickness	Color
LNC	(-)50°C ~ 200°C	PN25	≥ 2mm	White/Black conductive
DIN32676 coupling	(-)50°C ~ 200°C	PN16	2mm	White/Black conductive
MK and VK	(-)50°C ~ 200°C	PN25	2mm	White/Black conductive
DIN11851 coupling	(-)50°C ~ 200°C	PN16	≥ 2mm	White/Black conductive
Macon coupling	(-)50°C ~ 200°C	PN16	≥ 2mm	White/Black conductive
SS Kamlock	(-)50°C ~ 200°C	PN25	≥ 2mm	White/Black conductive
Flange hose ends	(-)50°C ~ 200°C	PN16	≥ 2mm	White/Black conductive
Guillemin	(-)50°C ~ 200°C	PN16	≥ 2mm	White/Black conductive
Composite	(-)50°C ~ 200°C	PN14	≥ 2mm	Black conductive

NOTES

Conductivity black coating: 10³ ~ 10⁵ Ω

For other items, the bigger sizes such as 3" the thickness for PFA link is about 2.5-3mm.

For DIN32676 coupling, the PFA lining of the disk is 1mm due to the limiting of standard dimensions.

TW - Kupplung Typ MK mit BSPP - Innengewinde (Komplett)

PFA ausgekleidet mit FKM Lippendichtung

Female coupler type MK BSPP female thread (complete) PFA coated - FKM lipgasket

Raccord type MK taraudé femelle BSPP (Complet) Revêtu de PFA - Joint à lèvres FKM

TW- Acople hembra tipo MK con rosca hembra BSPP (completo) Recubierto de PFA - FKM

TW Gniazdo typ MK z gwintem wewnętrznym BSPP (kompletny) Z powłoką PFA - Uszczelka profilowa FKM

TW - Tipo MK con filettato femmina BSPP (completo) Rivestimento in PFA - FKM

NEW



CONDUCTIVE

Part-No.	Material	WP	Shank	Thread	Price
2MKSPFA-W	SS 1.4408 PFA white coated	25 bar	DN50	G2"	
3MKSPFA-W	SS 1.4408 PFA white coated	25 bar	DN80	G3"	
4MKSPFA-W**	SS 1.4408 PFA white coated	25 bar	DN100	G4"	
2MKSPFA-B	SS 1.4408 PFA black coated	25 bar	DN50	G2"	
3MKSPFA-B	SS 1.4408 PFA black coated	25 bar	DN80	G3"	
4MKSPFA-B**	SS 1.4408 PFA black coated	25 bar	DN100	G4"	

**einteilig - mit O-Ring statt Lippendichtung

one piece - with O-Ring instead of lipgasket

TW - Kupplung Typ VK mit BSPP Innengewinde

PFA ausgekleidet

Male adapter type VK BSPP female thread - PFA coated

Raccord type VK taraudé femelle BSPP - Revêtu de PFA

TW- Racor macho tipo VK con rosca hembra BSPP - Recubierto de PFA

TW Wtyk typ VK z gwintem wewnętrznym BSPP - Z powłoką PFA

Raccordo maschio tipo VK filettato femmina BSPP Rivestimento in PFA

NEW



CONDUCTIVE

Part-No.	Material	WP	Shank	Thread	Price
2VKSPFA-W	SS 1.4408 PFA white coated	25 bar	DN50	G2"	
3VKSPFA-W	SS 1.4408 PFA white coated	25 bar	DN80	G3"	
4VKSPFA-W	SS 1.4408 PFA white coated	25 bar	DN100	G4"	
2VSPFA-B	SS 1.4408 PFA black coated	25 bar	DN50	G2"	
3VKSPFA-B	SS 1.4408 PFA black coated	25 bar	DN80	G3"	
4VKSPFA-B	SS 1.4408 PFA black coated	25 bar	DN100	G4"	



Vaterteil Schalenverschraubung mit gerilltem Stutzen und Sicherungsbund

PFA ausgekleidet

Male BSPP thread serrated hose shank and collar - PFA coated

Raccord mâle douille annelée à collerette BSPP - Revêtu de PFA

Acople rosca macho BSPP con espiga dentada recubierta de PFA

Część Męska z gwintem zewnętrznym BSPP z karbowaną końcówką do węża z wiązką zabezpieczającą - Z powłoką PFA

Accoppiamento filettato maschio BSPP Rivestimento in PFA

NEW

Part-No.	Material	WP	Shank	Thread	Price
SMSS25SPFA-W	SS 1.4408 PFA white coated	25 bar	DN25	1"	
SMSS32SPFA-W	SS 1.4408 PFA white coated	25 bar	DN32	1 1/4"	
SMSS38SPFA-W	SS 1.4408 PFA white coated	25 bar	DN38	1 1/2"	
SMSS50SPFA-W	SS 1.4408 PFA white coated	25 bar	DN50	2"	
SMSS65SPFA-W	SS 1.4408 PFA white coated	25 bar	DN63	2 1/2"	
SMSS75SPFA-W	SS 1.4408 PFA white coated	25 bar	DN75	3"	
SMSS100SPFA-W	SS 1.4408 PFA white coated	25 bar	DN100	4"	
SMSS25SPFA-B	SS 1.4408 PFA black coated	25 bar	DN25	1"	
SMSS32SPFA-B	SS 1.4408 PFA black coated	25 bar	DN32	1 1/4"	
SMSS38SPFA-B	SS 1.4408 PFA black coated	25 bar	DN38	1 1/2"	
SMSS50SPFA-B	SS 1.4408 PFA black coated	25 bar	DN50	2"	
SMSS65SPFA-B	SS 1.4408 PFA black coated	25 bar	DN63	2 1/2"	
SMSS75SPFA-B	SS 1.4408 PFA black coated	25 bar	DN75	3"	



Ω
CONDUCTIVE

PFA - ARMATUREN

Vaterteil Typ A - mit BSPP Innengewinde - flachdichtend

PFA ausgekleidet

Male adapter type A - with female BSPP thread - flat sealed - PFA coated

Adaptateur type A taraudé femelle - Revêtu de PFA

Camlock tipo A - acople macho - rosca hembra BSPP - Recubierto de PFA

Męczyzna Typ A zgodnie - Wtyk z gwintem wewnętrznym BSPP uszczelnienie płaskie - Z powłoką PFA

Camlock tipo A - versione maschio filettato femmina BSPP - Rivestimento in PFA

NEW



CONDUCTIVE

Part-No.	Material	WP	Dimension	Thread	Price
A100DINSSPFA-W	SS 1.4408 PFA white coated	25 bar	DN25	1"	
A125DINSSPFA-W	SS 1.4408 PFA white coated	25 bar	DN32	1 1/4"	
A150DINSSPFA-W	SS 1.4408 PFA white coated	25 bar	DN40	1 1/2"	
A200DINSSPFA-W	SS 1.4408 PFA white coated	25 bar	DN50	2"	
A250DINSSPFA-W	SS 1.4408 PFA white coated	25 bar	DN65	2 1/2"	
A300DINSSPFA-W	SS 1.4408 PFA white coated	25 bar	DN80	3"	
A100DINSSPFA-B	SS 1.4408 PFA black coated	25 bar	DN25	1"	
A125DINSSPFA-B	SS 1.4408 PFA black coated	25 bar	DN32	1 1/4"	
A150DINSSPFA-B	SS 1.4408 PFA black coated	25 bar	DN40	1 1/2"	
A200DINSSPFA-B	SS 1.4408 PFA black coated	25 bar	DN50	2"	
A250DINSSPFA-B	SS 1.4408 PFA black coated	25 bar	DN65	2 1/2"	
A300DINSSPFA-B	SS 1.4408 PFA black coated	25 bar	DN80	3"	

PFA - ARMATUREN



Mutterteil Typ C - mit gerilltem Schlauchstutzen

mit Sicherungsbund - PFA ausgekleidet - FKM Dichtung

Female coupler type C - with serrated shank and collar - PFA coated - FKM gasket

Coupleur type C - Douille annelée et collerette - Revêtu de PFA - Joint FKM

Camlock tipo C - acople hembra - espiga dentada y cuello de seguridad - Recubierto de PFA - Junta FKM

Kobieta Typ C zgodnie - Gniazdo z karbowaną końcówką do węża pod obejmę skorupową - Z powłoką PFA - FKM

Uszczelka

Camlock tipo C - Portagomma dentato versione femmina - Rivestimento in PFA - Guarnizione FKM

NEW

Part-No.	Material	WP	Dimension	Shank	Price
C100DINSSPFA-W	SS 1.4408 PFA white coated	25 bar	DN25	25mm	
C125DINSSPFA-W	SS 1.4408 PFA white coated	25 bar	DN32	32mm	
C150DINSSPFA-W	SS 1.4408 PFA white coated	25 bar	DN40	38mm	
C200DINSSPFA-W	SS 1.4408 PFA white coated	25 bar	DN50	50mm	
C250DINSSPFA-W	SS 1.4408 PFA white coated	25 bar	DN65	63mm	
C300DINSSPFA-W	SS 1.4408 PFA white coated	25 bar	DN80	75mm	
C100DINSSPFA-B	SS 1.4408 PFA black coated	25 bar	DN25	25mm	
C125DINSSPFA-B	SS 1.4408 PFA black coated	25 bar <td DN32	32mm		
C150DINSSPFA-B	SS 1.4408 PFA black coated	25 bar	DN40	38mm	
C200DINSSPFA-B	SS 1.4408 PFA black coated	25 bar	DN50	50mm	
C250DINSSPFA-B	SS 1.4408 PFA black coated	25 bar	DN65	63mm	
C300DINSSPFA-B	SS 1.4408 PFA black coated	25 bar	DN80	75mm	



Mutterteil Typ D - mit BSPP Innengewinde - flachdichtend

PFA ausgekleidet - FKM Dichtung

Female coupler type D - with female BSPP thread - PFA coated - FKM gasket

Coupleur type D taraudé femelle BSPP - Revêtu de PFA - Joint FKM

Camlock tipo D - acople hembra - rosca hembra BSPP - Recubierto de PFA - Junta FKM

Kobieta Typ D - Gniazdo z gwintem wewnętrznym BSPP - Z powłoką PFA - FKM Uszczelka

Camlock tipo D - versione femmina filettato femmina BSPP Rivestimento in PFA - Guarnizione FKM

NEW



CONDUCTIVE

Part-No.	Material	WP	Dimension	Thread	Price
D100DINSSPFA-W	SS 1.4408 PFA white coated	25 bar	DN25	1"	
D125DINSSPFA-W	SS 1.4408 PFA white coated	25 bar	DN32	1 1/4"	
D150DINSSPFA-W	SS 1.4408 PFA white coated	25 bar	DN40	1 1/2"	
D200DINSSPFA-W	SS 1.4408 PFA white coated	25 bar	DN50	2"	
D250DINSSPFA-W	SS 1.4408 PFA white coated	25 bar	DN65	2 1/2"	
D300DINSSPFA-W	SS 1.4408 PFA white coated	25 bar	DN80	3"	
D100DINSSPFA-B	SS 1.4408 PFA black coated	25 bar	DN25	1"	
D125DINSSPFA-B	SS 1.4408 PFA black coated	25 bar	DN32	1 1/4"	
D150DINSSPFA-B	SS 1.4408 PFA black coated	25 bar	DN40	1 1/2"	
D200DINSSPFA-B	SS 1.4408 PFA black coated	25 bar	DN50	2"	
D250DINSSPFA-B	SS 1.4408 PFA black coated	25 bar	DN65	2 1/2"	
D300DINSSPFA-B	SS 1.4408 PFA black coated	25 bar	DN80	3"	

PFA - ARMATUREN



Vaterteil Typ E - mit gerilltem Schlauchstutzen

mit Sicherungsbund - PFA ausgekleidet

Male adapter type E - with serrated shank and collar PFA coated

Adaptateur type E - Douille lisse et collerette - Revêtu de PFA

Camlock tipo E - acople macho - espiga dentada y cuello de seguridad - Recubierto de PFA -

Męczyzna Typ E zgodnie - Wtyk z gładką końcówką do węża pod obejmę skorupową Z powłoką PFA

Camlock tipo E - portagomma a resca e collare di sicurezza - Rivestimento in PFA

NEW

Part-No.	Material	WP	Dimension	Shank	Price
E100DINSSPFA-W	SS 1.4408 PFA white coated	25 bar	DN25	25mm	
E125DINSSPFA-W	SS 1.4408 PFA white coated	25 bar	DN32	32mm	
E150DINSSPFA-W	SS 1.4408 PFA white coated	25 bar	DN40	38mm	
E200DINSSPFA-W	SS 1.4408 PFA white coated	25 bar	DN50	50mm	
E250DINSSPFA-W	SS 1.4408 PFA white coated	25 bar	DN65	63mm	
E300DINSSPFA-W	SS 1.4408 PFA white coated	25 bar	DN80	75mm	
E100DINSSPFA-B	SS 1.4408 PFA black coated	25 bar	DN25	25mm	
E125DINSSPFA-B	SS 1.4408 PFA black coated	25 bar	DN32	32mm	
E150DINSSPFA-B	SS 1.4408 PFA black coated	25 bar	DN40	38mm	
E200DINSSPFA-B	SS 1.4408 PFA black coated	25 bar	DN50	50mm	
E250DINSSPFA-B	SS 1.4408 PFA black coated	25 bar	DN65	63mm	
E300DINSSPFA-B	SS 1.4408 PFA black coated	25 bar	DN80	75mm	



CONDUCTIVE

PFA - ARMATUREN



Guillemin Kupplung mit Rillenstutzen - mit Arretierung

mit Sicherungsbund - PFA ausgekleidet

Guillemin coupling with serrated hose shank - with latch - with collar - PFA coated

Raccord Guillemin à douille annelée - à verrou - avec collerette - Revêtu de PFA

Guillemin para manguera con cierre - con cuello de seguridad - Recubierto de PFA

Złącze Guillemin z karbowaną końcówką do węży -z pierścieniem blokującym -z wiązka zabezpieczającą Z powłoką PFA

Guillemin con portagomma - con chiusura - con collare di sicurezza - Rivestimento in PFA

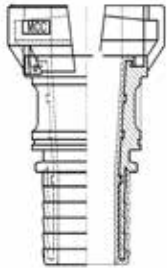
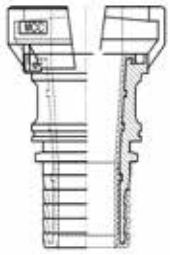

CONDUCTIVE

NEW

Part-No.	Material	WP	Dimension	Shank	Price
GH125SSPFA-W	SS 1.4408 PFA white coated	16 bar	DN32	32mm	
GH150SSPFA-W	SS 1.4408 PFA white coated	16 bar	DN40	38mm	
GH200SSPFA-W	SS 1.4408 PFA white coated	16 bar	DN50	50mm	
GH200SSPFA-B	SS 1.4408 PFA black coated	16 bar	DN50	50mm	
GH300SSPFA-B	SS 1.4408 PFA black coated	16 bar	DN80	76mm	
GH400SSPFA-B	SS 1.4408 PFA black coated	16 bar	DN100	100mm	

Guillemin Kupplung mit Einpresstutzen für Folienwickelschläuche

PFA ausgekleidet

Guillemin coupling with helico shank for composite hose - PFA coated

Raccord Guillemin à douille hélicoïdale pour tuyau composite - Revêtu de PFA

Guillemin con espiga helicoidal para mangueras composite - Recubierto de PFA

Złącze Guillemin do węży kompozytowego pod tuleję zaciskową -Z powłoką PFA

Guillemin con portagomma elicoidale per tubo composite - Rivestimento in PFA

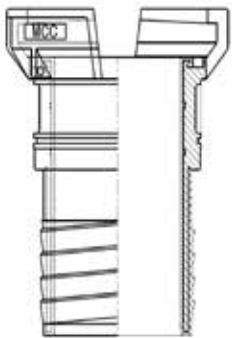

CONDUCTIVE

NEW

Part-No.	Material	WP	Dimension	Shank	Price
GST200SSPFA-B	SS 1.4408 PFA black coated	14 bar	DN50	50mm	
GST300SSPFA-B	SS 1.4408 PFA black coated	14 bar	DN80	76mm	
GST400SSPFA-B	SS 1.4408 PFA black coated	14 bar	DN100	100mm	



Einpressstutzen mit BSP AG für Folienwickelschläuche

PFA ausgekleidet

Male Thread with helico shank for composite hose - PFA coated

Raccord mâle BSP à douille hélicoïdale pour tuyau composite - Revêtu de PFA

Rosca macho con espiga helicoidal para mangueras composite - Recubierto de PFA

Złącze zaciskowe do węży kompozytowego z gwintem zewnętrznym BSP z - Z powłoką PFA

Accoppiamento filettatura maschio con portagomma elicoidale per tubo composite - Rivestimento in PFA

NEW

CONDUCTIVE

Part-No.	Material	WP	Dimension	Shank	Price
HST150SSPFA-B	SS 1.4408 PFA black coated	14 bar	DN40	40mm	
HST200SSPFA-B	SS 1.4408 PFA black coated	14 bar	DN50	50mm	
HST300SSPFA-B	SS 1.4408 PFA black coated	14 bar	DN80	76mm	
HST400SSPFA-B	SS 1.4408 PFA black coated	14 bar	DN100	100mm	

«CLAMP» Kupplung DIN32676 mit Rillenstutzen und Sicherungsbund

PFA ausgekleidet

Clamp coupling, PFA coated, with serrated hose shank and collar - DIN32676

Raccord micro-CLAMP, revêtu de PFA, à douille annelée à collerette - DIN32676

Racor Clamp con recubrimiento de PFA. Espiga con cuello de seguridad - DIN32676

Złącze «Clamp» (kotnierzowe) z karbowaną końcówką do węża z wiązką zabezpieczającą - DIN32676 - Z powłoką PFA

Raccordo Clamp, rivestito in PFA, portagomma e collare di sicurezza - DIN32676

NEW



CONDUCTIVE

Part-No.	Material	WP	Disk	Shank	Price
CLH106PFA-W	SS 1.4408 PFA white coated	16 bar	50.5	25	
CLH125PFA-W	SS 1.4408 PFA white coated	16 bar	50.5	32	
CLH156PFA-W	SS 1.4408 PFA white coated	16 bar	50.5	38	
CLH206PFA-W	SS 1.4408 PFA white coated	16 bar	64	51	
CLH256PFA-W	SS 1.4408 PFA white coated	16 bar	91	63	
CLH306PFA-W	SS 1.4408 PFA white coated	16 bar	106	76	
CLH406PFA-W	SS 1.4408 PFA white coated	16 bar	119	101,4	
CLH106PFA-B	SS 1.4408 PFA black coated	16 bar	50.5	25	
CLH125PFA-B	SS 1.4408 PFA black coated	16 bar	50.5	32	
CLH156PFA-B	SS 1.4408 PFA black coated	16 bar	50.5	38	
CLH206PFA-B	SS 1.4408 PFA black coated	16 bar	64	51	
CLH256PFA-B	SS 1.4408 PFA black coated	16 bar	91	63	
CLH306PFA-B	SS 1.4408 PFA black coated	16 bar	106	76	

PFA - ARMATUREN



Kegelstutzen nach DIN 11851, mit Rillenstutzen und Sicherungsbund

ohne Überwurfmutter - PFA ausgekleidet

Female DIN serrated hose shank with collar (without DIN NUT) - PFA coated

Femelle DIN douille annelée à collerette - Revêtu de PFA

Hembra DIN con espiga dentada y cuello de seguridad - Recubierto de PFA

zęść żeńska - zgodnie DIN 11851 - z karbowaną końcówką do węża z wiązką zabezpieczającą (bez nakrętki) - Z powłoką PFA

Bocchettone femmina portagomma DIN 11851 con collare di sicurezza (senza girella) - Rivestimento in PFA

NEW

Part-No.	Material	WP	Dimension	Shank	Price
DINHF25PFA-W	SS 1.4408 PFA white coated	16 bar	DN25	25mm	
DINHF32PFA-W	SS 1.4408 PFA white coated	16 bar	DN32	32mm	
DINHF40-38PFA-W	SS 1.4408 PFA white coated	16 bar	DN40	38mm	
DINHF50PFA-W	SS 1.4408 PFA white coated	16 bar	DN50	50mm	
DINHF65PFA-W	SS 1.4408 PFA white coated	16 bar	DN65	63mm	
DINHF80PFA-W	SS 1.4408 PFA white coated	16 bar	DN80	75mm	
DINHF25PFA-B	SS 1.4408 PFA black coated	16 bar	DN25	25mm	
DINHF32PFA-B	SS 1.4408 PFA black coated	16 bar	DN32	32mm	
DINHF40-38PFA-B	SS 1.4408 PFA black coated	16 bar	DN40	38mm	
DINHF50PFA-B	SS 1.4408 PFA black coated	16 bar	DN50	50mm	
DINHF65PFA-B	SS 1.4408 PFA black coated	16 bar	DN65	63mm	
DINHF80PFA-B	SS 1.4408 PFA black coated	16 bar	DN80	75mm	



CONDUCTIVE

PFA - ARMATUREN



Vaterteilstutzen nach DIN 11851 mit AG, Rillenstutzen und Sicherungsbund
(ohne Dichtung) - PFA ausgekleidet

Male DIN serrated hose shank with collar - (without gasket) - PFA coated

Mâle DIN douille annelée à collerette - sans joint - Revêtu de PFA

Macho din con espiga dentada y cuello de seguridad - sin junta - Recubierto de PFA

Część Męska z gwintem zewnętrznym zgodnie DIN 11851 z karbowaną końcówką do węża z wiązką zabezpieczającą (bez uszczelki)

Bocchettone femmina portagomma a resca DIN 11851 con collare di sicurezza (senza guarnizione) - Rivestimento in PFA

NEW



CONDUCTIVE

Part-No.	Material	WP	Couping	Shank	Price
DINHM25PFA-W	SS 1.4408 PFA white coated	16 bar	DN25	25mm	
DINHM32PFA-W	SS 1.4408 PFA white coated	16 bar	DN32	32mm	
DINHM40-38PFA-W	SS 1.4408 PFA white coated	16 bar	DN40	38mm	
DINHM50PFA-W	SS 1.4408 PFA white coated	16 bar	DN50	50mm	
DINHM65PFA-W	SS 1.4408 PFA white coated	16 bar	DN65	63mm	
DINHM80PFA-W	SS 1.4408 PFA white coated	16 bar	DN80	75mm	
DINHM25PFA-B	SS 1.4408 PFA black coated	16 bar	DN25	25mm	
DINHM32PFA-B	SS 1.4408 PFA black coated	16 bar	DN32	32mm	
DINHM40-38PFA-B	SS 1.4408 PFA black coated	16 bar	DN40	38mm	
DINHM50PFA-B	SS 1.4408 PFA black coated	16 bar	DN50	50mm	
DINHM65PFA-B	SS 1.4408 PFA black coated	16 bar	DN65	63mm	
DINHM80PFA-B	SS 1.4408 PFA black coated	16 bar	DN80	75mm	

PFA - ARMATUREN



Macon Mutterteil - Kupplung mit Rillenstutzen und Sicherungsbund

ohne Überwurfmutter - PFA ausgekleidet

Female Macon serrated shank with collar (without nut) - PFA coated

Femelle Macon douille annelée à collerette - Revêtu de PFA

Hembra Macon con espiga dentada y cuello de seguridad - Recubierto de PFA

Część Żeńska Macon - z karbowaną końcówką do węża z wiązką zabezpieczającą (bez nakrętki) - Z powłoką PFA

Raccordo femmina Macon portagomma con collare di sicurezza - Rivestimento in PFA

NEW

Part-No.	Material	WP	Coupling	Shank	Price
MACF038PFA-W	SS 1.4408 PFA white coated	16 bar	DN38	39mm	
MACF050PFA-W	SS 1.4408 PFA white coated	16 bar	DN50	50mm	
MACF070PFA-W	SS 1.4408 PFA white coated	16 bar	DN70	70mm	
MACF038PFA-B	SS 1.4408 PFA black coated	16 bar	DN38	39mm	
MACF050PFA-B	SS 1.4408 PFA black coated	16 bar	DN50	50mm	
MACF070PFA-B	SS 1.4408 PFA black coated	16 bar	DN70	70mm	



CONDUCTIVE

Macon Vaterteil - Kupplung mit Rillenstutzen und Sicherungsbund

ohne Dichtung - PFA ausgekleidet

Male Macon serrated shank with collar (without gasket) - PFA coated

Mâle Macon douille annelée à collerette - Revêtu de PFA

Macho Macon con espiga dentada y cuello de seguridad - Recubierto de PFA

Część Męska z gwintem zewnętrznym Macon z karbowaną końcówką do węża z wiązką zabezpieczającą (bez uszczelki)

Raccordo maschio Macon portagomma con collare di sicurezza - Rivestimento in PFA

NEW

Part-No.	Material	WP	Coupling	Shank	Price
MACM038PFA-W	SS 1.4408 PFA white coated	16 bar	DN38	39mm	
MACM050PFA-W	SS 1.4408 PFA white coated	16 bar	DN50	50mm	
MACM070PFA-W	SS 1.4408 PFA white coated	16 bar	DN70	70mm	
MACM038PFA-B	SS 1.4408 PFA black coated	16 bar	DN38	39mm	
MACM050PFA-B	SS 1.4408 PFA black coated	16 bar	DN50	50mm	
MACM070PFA-B	SS 1.4408 PFA black coated	16 bar	DN70	70mm	



CONDUCTIVE



Losflansch mit gerilltem Schlauchstutzen und Sicherungsbund

PFA ausgekleidet

Swivel flange coupling with serrated hose shank - PFA coated

Raccord à bride tournante douille annelée à collerette - Revêtu de PFA

Brida giratoria con espiga dentada y cuello de seguridad - Recubierto de PFA

Złącze kołnierzowe obrotowe z króćcem i z wiązką zabezpieczającą pod obejmę skorupowe - Z powłoką PFA

Flangia girevole con portagomma a resca e collare di sicurezza - Rivestimento in PFA

NEW



CONDUCTIVE

Part-No.	Material	WP	Coupling	Shank	Price
BS100R-SSPFA-W	SS 1.4408 PFA white coated	16 bar	DN25	25mm	
BS125R-SSPFA-W	SS 1.4408 PFA white coated	16 bar	DN32	32mm	
BS150R-SS-38PFA-W	SS 1.4408 PFA white coated	16 bar	DN40	38mm	
BS200R-SSPFA-W	SS 1.4408 PFA white coated	16 bar	DN50	51mm	
BS250R-SS-63PFA-W	SS 1.4408 PFA white coated	16 bar	DN65	63mm	
BS300R-SS-75PFA-W	SS 1.4408 PFA white coated	16 bar	DN80	75mm	
BS100R-SSPFA-B	SS 1.4408 PFA black coated	16 bar	DN25	25mm	
BS200R-SSPFA-B	SS 1.4408 PFA black coated	16 bar	DN50	51mm	
BS250R-SS-63PFA-B	SS 1.4408 PFA black coated	16 bar	DN65	63mm	
BS300R-SS-75PFA-B	SS 1.4408 PFA black coated	16 bar	DN80	75mm	



LEBENSMITTEL- INDUSTRIE

Clamp Kupplungen	226
Milchrohrverschraubung	242
SMS Kupplung	276
Macon Kupplung	290

INFORMATIONEN

Clamp Kupplungen

Die Clamp Verbindungen stellen eine Standardverbindung in der Lebensmittel- und Pharma-Industrie dar. Hierbei sind die drei Rohrklassen zu beachten: Die metrische Reihe A nach DIN 11866, die zöllige Reihe B sowie die ASME Reihe C. Die Rohrklasse gibt bezogen auf das Clamp-Flanschmaß den Innendurchmesser der Clamps an.

Es können daher verschiedene Innendurchmesser bei gleichem Flanschmaß vorhanden sein. MCC nutzt die hier in Europa übliche metrische Reihe (siehe Tabelle).

Clamps sollten in hoher Oberflächenqualität, aus dem Vollen zerspannt und sehr maßhaltig sein, um die immer strenger

werdenden Hygieneanforderungen zu erfüllen.

DN	Flansch	ID
15,20	34mm	16, 20mm
25,32,38	50,5mm	26, 32, 38mm
50	64mm	50mm
65	91mm	66mm
80/75	106mm	81mm



WARUM MCC?

- Wir erfüllen die Hygiene Norm H3 auf Wunsch auch HE3
- MCC Clamp Armaturen sind absolut maßhaltig und besitzen eine Chargenkennzeichnung
- Die Clamp Verbindungen sind auch mit dicker und absolut diffusionsdichter PFA-Auskleidung erhältlich (auch antistatisch in schwarz verfügbar)
- Ausführungen mit Schlauchstutzen nach DIN EN 14420 oder rohrrseitig mit Anschweißende verfügbar
- Übergangsstücke, Reduzierungen und Adapter für andere Anschlussstypen aus einer Hand auf Lager

TECHNISCHE INFORMATIONEN

- Norm: DIN 32676 H3 (BS4825, ISO2852)
- Gewindeanschlüsse nach DIN 11851 (Milchrohr) und S60 x 6 Fassgewinde
- Schlauchanschluss nach DIN EN 14420 für Elastomerschläuche
- H3 Oberfläche, Ra von 0,8µm
- Chargennachweis
- Werkstoffe:
1.4404

EINSATZGEBIET

Dieser Armaturen Typ wird insbesondere in der Lebensmittel- und Pharmaindustrie eingesetzt. Clamp nach DIN32676 ist in länger bestehenden Anlagen europaweit zu finden. Modernere Anlagen nutzen den nicht zu verwechselnden DIN 11864-3 Clamp Standard.

Häufig werden Clamps für schnell zu verlegende Leitungen genutzt und zum Ankuppeln aus anderen Systemen wie IBC-Containern, so dass Adapter sehr häufig benötigt werden.

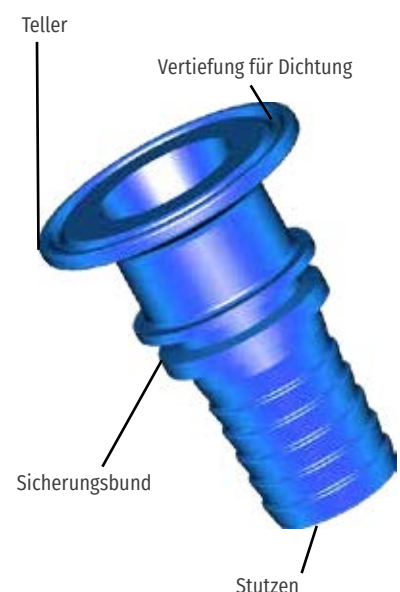



INFORMATION

Clamp Couplings

Clamp connections are a standard connection in the food and pharmaceutical industry. The three pipe classes must be observed here: The metric series A according to DIN 11866, the imperial series B and the ASME series C. The pipe class indicates the internal diameter of the clamps in relation to the clamp flange dimension.

It is therefore possible to have different inside diameters with the same flange dimension. MCC uses the metric series commonly used here in Europe (see table).

Clamps should have a high surface quality, be machined from solid material and be very dimensionally accurate in

order to meet the increasingly stringent hygiene requirements.

DN	Flange	ID
15,20	34mm	16, 20mm
25,32,38	50,5mm	26, 32, 38mm
50	64mm	50mm
65	91mm	66mm
80/75	106mm	81mm

WHY MCC?

- We comply with the H3 hygiene standard, also HE3 on request available
- MCC clamp couplings are dimensionally stable and have batch labeling
- The clamp couplings are also available with a thick and absolutely diffusion-tight PFA lining (also available in antistatic black)
- Versions with hose connectors in accordance with DIN EN 14420 or with weld-on ends on the pipe side available
- Transition pieces, reducers and adapters for other connection types on stock



TECHNICAL INFORMATION

- Norm: DIN 32676 H3 (BS4825, ISO2852)
- Threaded connections according to DIN 11851 (milk pipe) and S60 x 6 barrel thread
- Hose connection according to DIN EN 14420 for elastomer hoses
- H3 surface, Ra von 0,8µm
- Heat-Numbers
- Materials:
1.4404

AREA OF APPLICATION

This type of couplings is used in particular in the food and pharmaceutical industry. Clamp according to DIN32676 can be found in longer existing systems throughout Europe. More modern systems use the DIN 11864-3 clamp standard, which should not be confused.

Clamps are often used for lines that need to be laid quickly and for coupling from other systems such as IBC containers, meaning that adapters are very often required.

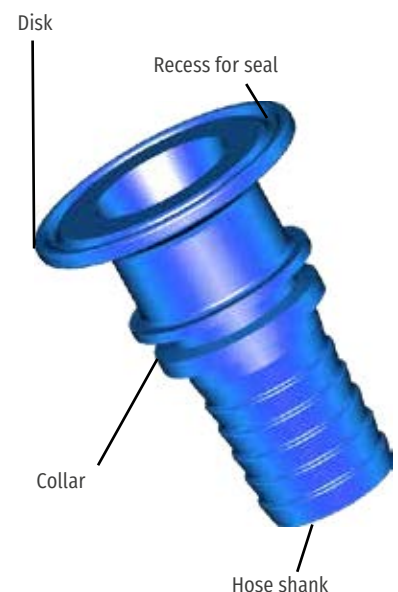



«CLAMP» Kupplung DIN32676, mit Rillenstutzen und Sicherungsbund

Clamp coupling with serrated hose shank and collar - DIN32676

Raccord micro-CLAMP à douille annelée à collerette- DIN32676

Racor Clamp con espiga dentada y cuello de seguridad - DIN32676

Złącze «Clamp» (kotnierzowe) z karbowaną końcówką do węża z wiązką zabezpieczającą - DIN32676

Raccordo Clamp portagomma con collare di sicurezza - DIN32676

Part-No.	Material	WP	Disk	Shank	Price
CLH051	SS 1.4404	25 bar	34	13	
CLH076	SS 1.4404	25 bar	34	19	
CLH106	SS 1.4404	25 bar	50.5	25	
CLH125	SS 1.4404	25 bar	50.5	32	
CLH156	SS 1.4404	25 bar	50.5	38	
CLH200	SS 1.4404	25 bar	64	50	
CLH206	SS 1.4404	25 bar	64	51	
CLH256	SS 1.4404	25 bar	91	63	
CLH300	SS 1.4404	25 bar	106	75	
CLH306	SS 1.4404	25 bar	106	76	
CLH406	SS 1.4404	25 bar	119	101.4	



«CLAMP» Kupplung, mit Rillenstutzen und Sicherungsbund - BS4825

Clamp coupling with serrated hose shank and collar - BS4825

Raccord micro-CLAMP à douille annelée à collerette - BS4825

Racor Clamp con espiga dentada y cuello de seguridad - BS4825

Złącze «Clamp» (kotnierzowe) z karbowaną końcówką do węża z wiązką zabezpieczającą - BS4825

Raccordo Clamp portagomma con collare di sicurezza - BS4825

Part-No.	Material	WP	Disk	Shank	Price
CLH051BS	SS 1.4404	25 bar	25,2	13	
CLH076BS	SS 1.4404	25 bar	25,2	19	
CLH256BS	SS 1.4404	25 bar	77,4	63	
CLH306BS	SS 1.4404	25 bar	91	76	



«CLAMP» Kuplung, mit Rillenstutzen und Sicherungsbund - ISO2852

Clamp coupling with serrated hose shank and collar - ISO2852

Raccord micro-CLAMP à douille annelée à collerette- ISO2852

Racor Clamp con espiga dentada y cuello de seguridad - ISO2852

Złącze «Clamp» (kołnierzowe) z karbowaną końcówką do węża z wiązką zabezpieczającą - ISO2852

Raccordo Clamp portagomma con collare di sicurezza - ISO2852



Part-No.	Material	WP	Disk	Shank	Price
CLH076ISO	SS 1.4404	25 bar	50,4	19	
CLH156ISO	SS 1.4404	25 bar	64	38	
CLH206ISO	SS 1.4404	25 bar	77,4	51	
CLH406ISO	SS 1.4404	25 bar	130	101.4	

«CLAMP» Kuplung DIN32676, mit glattem Stutzen und Sicherungsbund

Clamp coupling with smooth hose shank and collar - DIN32676

Raccord micro-CLAMP à douille lisse à collerette - DIN32676

Racor Clamp con espiga lisa y cuello de seguridad - DIN32676

Złącze «Clamp» (kołnierzowe) z gładką końcówką do węża z wiązką zabezpieczającą - DIN32676

Raccordo Clamp portagomma liscio con collare di sicurezza - DIN32676



Part-No.	Material	WP	Disk	Shank	Price
CLH051ST	SS 1.4404	25 bar	34	13	
CLH076ST	SS 1.4404	25 bar	34	19	
CLH106ST	SS 1.4404	25 bar	50.5	25	
CLH125ST	SS 1.4404	25 bar	50.5	32	
CLH156ST	SS 1.4404	25 bar	50.5	38	
CLH200ST	SS 1.4404	25 bar	64	50	
CLH206ST	SS 1.4404	25 bar	64	51	
CLH256ST	SS 1.4404	25 bar	91	63	
CLH300ST	SS 1.4404	25 bar	106	75	
CLH306ST	SS 1.4404	25 bar	106	76	



PFA ausgekleidete - «CLAMP» Kupplung DIN32676

mit Rillenstutzen und Sicherungsbundt

Clamp coupling, PFA coated, with serrated hose shank and collar - DIN32676

Raccord micro-CLAMP, revêtu de PFA, à douille annelée à collerette - DIN32676

Racor Clamp con recubrimiento de PFA. Espiga con cuello de seguridad - DIN32676

Złącze «Clamp» (kotnierzowe) z karbowaną końcówką do węża z wiązką zabezpieczającą - DIN32676

Raccordo Clamp, rivestito in PFA, portagomma e collare di sicurezza - DIN32676

NEW

CONDUCTIVE

Part-No.	Material	WP	Disk	Shank	Price
CLH106PFA-W	SS 1.4404 PFA white coated	16 bar	50.5	25	
CLH125PFA-W	SS 1.4404 PFA white coated	16 bar	50.5	32	
CLH156PFA-W	SS 1.4404 PFA white coated	16 bar	50.5	38	
CLH206PFA-W	SS 1.4404 PFA white coated	16 bar	64	51	
CLH256PFA-W	SS 1.4404 PFA white coated	16 bar	91	63	
CLH306PFA-W	SS 1.4404 PFA white coated	16 bar	106	76	
CLH406PFA-W	SS 1.4404 PFA white coated	16 bar	119	101,4	
CLH106PFA-B	SS 1.4404 PFA black coated	16 bar	50.5	25	
CLH125PFA-B	SS 1.4404 PFA black coated	16 bar	50.5	32	
CLH156PFA-B	SS 1.4404 PFA black coated	16 bar	50.5	38	
CLH206PFA-B	SS 1.4404 PFA black coated	16 bar	64	51	
CLH256PFA-B	SS 1.4404 PFA black coated	16 bar	91	63	
CLH306PFA-B	SS 1.4404 PFA black coated	16 bar	106	76	



«CLAMP» Kupplung DIN32676, mit Rillenstutzen 45° und Sicherungsbund

Clamp coupling with serrated hose shank 45° and collar - DIN32676

Raccord micro-CLAMP à douille annelée 45° à collerette - DIN32676

Codo 45° Clamp con espiga dentada y cuello de seguridad - DIN32676

Złącze «Clamp» (kołnierzowe) z karbowaną końcówką do węża 45° z wiązką zabezpieczającą - DIN32676

Clamp con Curva a 45° - portagomma a resca e collare di sicurezza - DIN32676



Part-No.	Material	WP	Disk	Shank	Price
CLH051-45	SS 1.4404	25 bar	34	13	
CLH076-45	SS 1.4404	25 bar	34	19	
CLH106-45	SS 1.4404	25 bar	50.5	25	
CLH125-45	SS 1.4404	25 bar	50.5	32	
CLH156-45	SS 1.4404	25 bar	50.5	38	
CLH206-45	SS 1.4404	25 bar	64	51	
CLH256-45	SS 1.4404	25 bar	91	63	
CLH306-45	SS 1.4404	25 bar	106	76	

«CLAMP» Kupplung DIN32676, mit Rillenstutzen 90° und Sicherungsbund

Clamp coupling with serrated hose shank 90° and collar - DIN32676

Raccord micro-CLAMP à douille annelée 90° à collerette - DIN32676

Codo 90° Clamp con espiga dentada y cuello de seguridad - DIN32676

Złącze «Clamp» (kołnierzowe) z karbowaną końcówką do węża 90° z wiązką zabezpieczającą - DIN32676

Clamp con Curva a 90° - portagomma a resca e collare di sicurezza - DIN32676



Part-No.	Material	WP	Disk	Shank	Price
CLH051-90	SS 1.4404	25 bar	34	13	
CLH076-90	SS 1.4404	25 bar	34	19	
CLH106-90	SS 1.4404	25 bar	50.5	25	
CLH125-90	SS 1.4404	25 bar	50.5	32	
CLH156-90	SS 1.4404	25 bar	50.5	38	
CLH206-90	SS 1.4404	25 bar	64	51	
CLH256-90	SS 1.4404	25 bar	91	63	
CLH306-90	SS 1.4404	25 bar	106	76	





«CLAMP» Kupplung DIN32676 Reduzierung

«Clamp» coupling reducer - DIN32676
 Raccord micro-«Clamp» Réduction - DIN32676
 Reducción Clamp - DIN32676
 Złącze «Clamp» Redukcja - DIN32676
 Riduzione Clamp - DIN32676

Part-No.	Material	WP	Disk	Disk	Price
CL156CL076	SS 1.4404	25 bar	50.5	34	
CL206CL156	SS 1.4404	25 bar	64	50.5	
CL256CL206	SS 1.4404	25 bar	91	64	
CL306CL206	SS 1.4404	25 bar	106	64	
CL306CL256	SS 1.4404	25 bar	106	91	



Clampbogen 45°, beidseitig «Clamp» Kupplung DIN32676

«Clamp» Coupling, 45° Elbow with both sides «Clamp» Coupling - DIN32676
 «Clamp» Coude 45° - Raccord micro-CLAMP à Raccord micro-CLAMP - DIN32676
 Codo 45°. Clamp - Clamp - DIN32676
 45° Kolano obustronny Złącze «Clamp» (kotnierzowe) - DIN32676
 Curva 45°. Clamp - Clamp - DIN32676

Part-No.	Material	WP	Dimension	Disk	Price
CL076CL076-45	SS 1.4404	25 bar	DN20	34mm	
CL106CL106-45	SS 1.4404	25 bar	DN25	50,5mm	
CL125CL125-45	SS 1.4404	25 bar	DN32	50,5mm	
CL156CL156-45	SS 1.4404	25 bar	DN40	50,5mm	
CL206CL206-45	SS 1.4404	25 bar	DN50	64mm	
CL256CL256-45	SS 1.4404	25 bar	DN65	91mm	
CL306CL306-45	SS 1.4404	25 bar	DN80	106mm	



Clampbogen 90°, beidseitig «Clamp» Kuplung DIN32676

«Clamp» , 90° Elbow with both sides «Clamp» Coupling - DIN32676

«Clamp» Coude 90° - Raccord micro-CLAMP à Raccord micro-CLAMP - DIN32676

Codo 90°. Clamp - Clamp - DIN32676

90° Kolano obustronny Złącze «Clamp» (kotnierzowe) - DIN32676

Curva 90°. Clamp - Clamp - DIN32676



Part-No.	Material	WP	Dimension	Disk	Price
CL076CL076-90	SS 1.4404	25 bar	DN20	34mm	
CL106CL106-90	SS 1.4404	25 bar	DN25	50,5mm	
CL125CL125-90	SS 1.4404	25 bar	DN32	50,5mm	
CL156CL156-90	SS 1.4404	25 bar	DN40	50,5mm	
CL206CL206-90	SS 1.4404	25 bar	DN50	64mm	
CL256CL256-90	SS 1.4404	25 bar	DN65	91mm	
CL306CL306-90	SS 1.4404	25 bar	DN80	106mm	

Clampbogen 90°, «Clamp» Kuplung DIN32676 - auf Anschweißende

«Clamp» Coupling, 90° Elbow, «Clamp» Coupling to welding end - DIN32676

«Clamp» Coude 90° - Femelle à souder - DIN32676

Codo Clamp 90° para soldar - DIN32676

Złącze «Clamp» (kotnierzowe) z 90° Kolanem i z króćcem do dospawania - DIN32676

Curva Clamp 90° a saldare - DIN32676



Part-No.	Material	WP	Dimension	Disk	BW (IDxOD)	Price
CLH076BW-90	SS 1.4404	25 bar	DN20	34mm	20x23	
CLH106BW-90	SS 1.4404	25 bar	DN25	50,5mm	26x29	
CLH125BW-90	SS 1.4404	25 bar	DN32	50,5mm	32x35	
CLH156BW-90	SS 1.4404	25 bar	DN40	50,5mm	38x41	
CLH206BW-90	SS 1.4404	25 bar	DN50	64mm	50x53	
CLH256BW-90	SS 1.4404	25 bar	DN65	91mm	66x70	
CLH306BW-90	SS 1.4404	25 bar	DN80	106mm	81x85	





90° Bogen AG/AG BSPP flachdichtend

90° Elbow male BSPP thread - flat sealing

90° Coude mâle/mâle à joint plat

Codo 90° RM-RM BSPP

90° Lolanoz gwintami zewnętrznymi cylindrycznymi

Curva 90° maschio - maschio BSPP

Part-No.	Material	WP	Thread	Thread	Price
MMS075075FL-90	SS 316	16 bar	3/4"	3/4"	
MMS1010FL-90	SS 316	16 bar	1"	1"	
MMS1212FL-90	SS 316	16 bar	1 1/4"	1 1/4"	
MMS1515FL-90	SS 316	16 bar	1 1/2"	1 1/2"	
MMS2020FL-90	SS 316	16 bar	2"	2"	
MMS3030FL-90	SS 316	16 bar	3"	3"	
MMS4040FL-90	SS 316	16 bar	4"	4"	



CLAMP Kupplung DIN32676 mit IBC Innengewinde - ohne Dichtung

Clamp coupling - DIN32676 with IBC female thread - without gasket

Raccord micro-CLAMP - DIN32676 avec Filetage IBC femelle- sans joint

Racor Clamp con rosca - DIN32676 hembra IBC - sin junta

Złącze «Clamp» - DIN32676/ Złącze IBC z gwintem wewnętrznym - bez Uszczelka

Raccordo clamp - DIN32676 con filettatura femmina IBC- senza guarnizione

Part-No.	Material	WP	IBC	Disk	Price
IBCF60CLH051-SS	SS 1.4404	25 bar	S60x6	34	
IBCF60CLH106-SS	SS 1.4404	25 bar	S60x6	50,5	
IBCF60CLH206-SS	SS 1.4404	25 bar	S60x6	64	
IBCF60CLH256-SS	SS 1.4404	25 bar	S60x6	91	



«CLAMP» Kupplung DIN32676 auf BSPP Innengewinde

«Clamp» coupling to BSPP female thread - DIN32676

Raccord micro-«Clamp» - Taraudage femelle BSPP - DIN32676

Racor Clamp - rosca hembra BSPP - DIN32676

Złącze «Clamp» z gwintem wewnętrznym BSPP - DIN32676

Accoppiamento «Clamp» - filettatura femmina BSPP - DIN32676



Part-No.	Material	WP	Disk	Thread	Price
CLH051IG	SS 1.4404	25 bar	34	1/2"	
CLH076IG	SS 1.4404	25 bar	34	3/4"	
CLH106IG	SS 1.4404	25 bar	50.5	1"	
CLH125IG	SS 1.4404	25 bar	50.5	1 1/4"	
CLH156IG	SS 1.4404	25 bar	50.5	1 1/2"	
CLH206IG	SS 1.4404	25 bar	64	2"	
CLH256IG	SS 1.4404	25 bar	91	2 1/2"	
CLH306IG	SS 1.4404	25 bar	106	3"	

«CLAMP» Kupplung DIN32676 auf BSPP Außengewinde

Clamp coupling to BSPP male thread - DIN32676

Raccord micro-CLAMP à - Filetage mâle BSPP - DIN32676

Racor Clamp - rosca macho BSPP - DIN32676

Złącze «Clamp» z gwintem zewnętrznym BSPP - DIN32676

Accoppiamento Clamp - filettatura maschio BSPP - DIN32676



Part-No.	Material	WP	Disk	Thread	Price
CLH051AG	SS 1.4404	25 bar	34	1/2"	
CLH076AG	SS 1.4404	25 bar	34	3/4"	
CLH106AG	SS 1.4404	25 bar	50.5	1"	
CLH125AG	SS 1.4404	25 bar	50.5	1 1/4"	
CLH156AG	SS 1.4404	25 bar	50.5	1 1/2"	
CLH206AG	SS 1.4404	25 bar	64	2"	
CLH256AG	SS 1.4404	25 bar	91	2 1/2"	
CLH306AG	SS 1.4404	25 bar	106	3"	



«CLAMP» Kappe DIN32676

Clamp Cap - DIN32676

Raccord-CLAMP bouchon - DIN32676

Tapón Clamp - DIN32676

«Clamp» Korek - DIN32676

Tappo Clamp - DIN32676

Part-No.	Material	WP	Disk	Price
CLCAP076	SS 1.4404	16 bar	34	
CLCAP156	SS 1.4404	16 bar	50.5	
CLCAP206	SS 1.4404	16 bar	64	
CLCAP256	SS 1.4404	16 bar	91	
CLCAP306	SS 1.4404	16 bar	106	
CLCAP406	SS 1.4404	16 bar	119	

**Übergangsstück Kegelstutzen DIN 11851 mit Überwurfmutter auf «Clamp» Kupplung DIN32676**

Adapter DIN female with nut to «Clamp» coupling - DIN32676

Adaptateur DIN Femelle avec Ecrou - avec Raccord micro-«Clamp» - DIN32676

Adaptador hembra DIN 11851 con tuerca a racor «Clamp» - DIN32676

Adapter DIN 11851 - Część żeńska z nakrętką na końcówkę / Złącze «Clamp» - DIN32676-

Adattatore DIN femmina con girella - raccordo «Clamp» - DIN32676

Part-No.	Material	WP	DINHF	Disk	Price
DINHF20CLH076	SS 1.4404	25 bar	DN20	34	
DINHF25CLH106	SS 1.4404	25 bar	DN25	50,5	
DINHF32CLH125	SS 1.4404	25 bar	DN32	50,5	
DINHF40CLH156	SS 1.4404	25 bar	DN40	50,5	
DINHF50CLH206	SS 1.4404	25 bar	DN50	64	
DINHF65CLH256	SS 1.4404	25 bar	DN65	91	
DINHF80CLH306	SS 1.4404	25 bar	DN80	106	



Übergangsstück «CLAMP» Kupplung DIN32676 auf DIN 11851 Außengewinde

Adapter «Clamp» coupling - DIN32676 to male DIN
 Adaptateur Raccord micro-«Clamp» - DIN32676 avec Mâle DIN
 Racor «Clamp» - DIN32676 con Macho DIN 11851
 Adapter Złącze «Clamp» - DIN32676/DIN 11851 - Część Męska
 Racor «Clamp» - DIN32676 con Macho DIN 11851



Part-No.	Material	WP	DINHM	Disk	Price
DINHM20CLH076	SS 1.4404	25 bar	DN20	34	
DINHM25CLH106	SS 1.4404	25 bar	DN25	50,5	
DINHM32CLH125	SS 1.4404	25 bar	DN32	50,5	
DINHM40CLH156	SS 1.4404	25 bar	DN40	50,5	
DINHM50CLH206	SS 1.4404	25 bar	DN50	64	
DINHM65CLH256	SS 1.4404	25 bar	DN65	91	
DINHM80CLH306	SS 1.4404	25 bar	DN80	106	

CLAMP Kupplung DIN32676 auf SMS 1145 Außengewinde

Clamp coupling - DIN32676 to male SMS 1145
 Raccord micro-CLAMP - DIN32676 avec Mâle SMS 1145
 Racor «Clamp» - DIN32676 con Macho SMS 1145
 Złącze «Clamp» - DIN32676 / Część Męska 1145
 Raccordo Clamp - DIN32676 con maschio SMS 1145



Part-No.	Material	WP	SMS	Disk	Price
SMSHM25CLH106	SS 1.4404	25 bar	DN25	50.5	
SMSHM32CLH125	SS 1.4404	25 bar	DN32	50.5	
SMSHM38CLH156	SS 1.4404	25 bar	DN38	50.5	
SMSHM50CLH206	SS 1.4404	25 bar	DN50	64	
SMSHM63CLH256	SS 1.4404	25 bar	DN63	91	
SMSHM76CLH306	SS 1.4404	25 bar	DN76	106	



Schauglas aus Borosilikatglas mit beidseitigem Clampteller DIN32676

Montierte Schutzstäbe aus SS 1.4301

Tubular sight glass with clamp ends, borosilicate glass, SS 1.4301 protective rods - DIN32676

Viseur tubulaire clamp - clamp, verre borosilicate, barres de protection SS 1.4301 - DIN32676

Mirilla tubular clamp - clamp, varillas protectoras SS 1.4301, vidrio borosilicatado - DIN32676

wziernik ze szkła borokrzemowego z płytką zaciskową po obu stronach - DIN32676

Specola di Linea con attacchi Clamp, vetro borosilicato, aste di protezione montate SS 1.4301 - DIN32676

Part-No.	Material	WP	Dimension	Disk	Price
CL106CL106-SG	Borosilicate / SS 1.4404	16 bar	DN25	50,5mm	
CL125CL125-SG	Borosilicate / SS 1.4404	16 bar	DN32	50,5mm	
CL156CL156-SG	Borosilicate / SS 1.4404	16 bar	DN40	50,5mm	
CL206CL206-SG	Borosilicate / SS 1.4404	16 bar	DN50	64mm	
CL256CL256-SG	Borosilicate / SS 1.4404	16 bar	DN65	91mm	
CL306CL306-SG	Borosilicate / SS 1.4404	16 bar	DN80	106mm	
CL406CL406-SG	Borosilicate / SS 1.4404	16 bar	DN100	119mm	



Ersatz Schutzgitter für Lebensmittelschaugläser

Replacement net case for sight glass

Filet de remplacement pour le verre de regard

Funda de red de repuesto para mirilla

Wymienna obudowa siatki do wziernika

Custodia di ricambio in rete per il vetro spia

Part-No.	Material	Dimension	Price
REPCASE1-SG	SS 304	DN25	
REPCASE1.25-SG	SS 304	DN32	
REPCASE1.5-SG	SS 304	DN40	
REPCASE2-SG	SS 304	DN50	
REPCASE2.5-SG	SS 304	DN65	
REPCASE3-SG	SS 304	DN80	
REPCASE4-SG	SS 304	DN100	



«CLAMP» Kupplung DIN32676, Anschweißende

Clamp coupling with welding end - DIN32676

Raccord micro-CLAMP à souder - DIN32676

Casquillo para soldar Clamp - DIN32676

Złącze «Clamp» (kotnierzowe) z króćcem do dospawania - DIN32676

Accoppiamento Clamp a saldare - DIN32676



Part-No.	Material	WP	Disk	Welding	Price
CLH051BW	SS 1.4404	25 bar	34	16x19	
CLH076BW	SS 1.4404	25 bar	34	20x23	
CLH106BW	SS 1.4404	25 bar	50.5	26x29	
CLH125BW	SS 1.4404	25 bar	50.5	32x35	
CLH156BW	SS 1.4404	25 bar	50.5	38x41	
CLH206BW	SS 1.4404	25 bar	64	50x53	
CLH256BW	SS 1.4404	25 bar	91	66x70	
CLH306BW	SS 1.4404	25 bar	106	81x85	
CLH406BW	SS 1.4404	25 bar	119	100x104	



Verschluss-Klammer für «CLAMP» Kupplung

Clamp hinge

Collier sans joint pour raccord CLAMP

Abrazadera CLamp

Obejma «Clamp» do złączy kołnierzowej

Morsetto doppio snodo Clamp

NEW



Part-No.	Material	WP	for Disk	Price
CLC054	SS 1.4301	25 bar	25	
CLC104	SS 1.4301	25 bar	34	
CLC154	SS 1.4301	25 bar	50.5	
CLC204	SS 1.4301	25 bar	64	
CLC254	SS 1.4301	25 bar	77	
CLC304	SS 1.4301	25 bar	91	
CLC354	SS 1.4301	25 bar	106	
CLC404	SS 1.4301	25 bar	119	
CLC054-2	SS 1.4301	25 bar	25	
CLC104-2	SS 1.4301	25 bar	34	
CLC154-2	SS 1.4301	25 bar	50.5	
CLC204-2	SS 1.4301	25 bar	64	
CLC254-2	SS 1.4301	25 bar	77	
CLC304-2	SS 1.4301	25 bar	91	
CLC354-2	SS 1.4301	25 bar	106	
CLC404-2	SS 1.4301	25 bar	119	



PE Clamp Schutzkappe

PE Clamp protection cap
 Capuchon de protection en PE
 Tapa protectora de
 Nakładka ochronna
 Cappuccio di protezione

**NEW**

Part-No.	Material	for Disk	Price
CAP25.4PE-T	PE	25.4	
CAP34.0PE-T	PE	34	
CAP50.5PE-T	PE	50.5	
CAP64.0PE-T	PE	64	
CAP77.4PE-T	PE	77.4	
CAP91.0PE-T	PE	91	
CAP106.0PE-T	PE	106	
CAP119.0PE-T	PE	119	



INFORMATIONEN

Milchrohrverschraubung DIN 11851



Diese Armaturenreihe vereint zwei bewährte Normen: die Gewindenorm DIN 405-1 und die Fittinggeometrie DIN 32676. Ein besonderes Merkmal dieser Verschraubung ist ihre optimierte Dichtwirkung. Durch einen 5°-Winkel an der Dichtfläche wird nur ein Teil der Dichtung gezielt angepresst. Dies erleichtert das Verschrauben und erhöht gleichzeitig

die Zuverlässigkeit der Abdichtung.

Unter dem Namen „Milchrohrverschraubung“ hat sich diese Lösung als nahezu universeller Standard etabliert. Sie vereint die Vorteile einer schnell zu montierenden Armatur mit den Eigenschaften eines robusten Systems. Damit gleicht sie die Schwächen vieler

Schnellkupplungen der DIN EN 14420 aus. Besonders bewährt hat sich diese Verschraubung bei Dampfschläuchen nach DIN 6134. Dank ihrer durchdachten Konstruktion reicht oft ein einfaches Handanziehen aus, um eine zuverlässige Verbindung herzustellen. Für eine noch festere Fixierung kann ein Hakenschlüssel nach DIN 810 verwendet werden.

WARUM MCC?

- Die Gewinde werden nach Lehdornen geschnitten und geprüft.
- Die Armaturen werden spanend aus Stangenmaterial hergestellt
- Die Oberflächen entsprechen dem Hygienestandard H3
- Korrekte Dichtring-Einstichtiefe und der 5°-Winkel und der Kegeldurchmesser des Kupplungsteils
- Die Dichtringe sind in verschiedenen Qualitäten verfügbar.
- Alle Gewinde sind entgratet
- Die Schlauchstützen entsprechen der DIN EN 14420, DIN 14423 und weiteren Standards



TECHNISCHE INFORMATIONEN

- Norm: DIN 405-1 sowie DIN 11851
- Nennweiten: DN25 bis DN 100 auch Deckel und Stopfen
- Auch hier darf diese Armatur nicht mit der DIN 11864-1 verwechselt werden, die kompatibles Rundgewinde aber ein anderes Dichtungssystem besitzt.
- H3 Oberfläche, Ra von 0,8µm
- Chargennachweis
- Werkstoffe: 1.4404 - Nutmutter 1.4301 auch PFA ausgekleidet verfügbar
- Adaptervielfalt: S60x6 Gewinde, Reduzierer, ISO 228 IG und AG, Bögen, Tri Clamp, SMS, Macon

h. Zubehör: Prallschutz für Überwurfmutter, Schaugläser

EINSATZGEBIET

Nahezu universelle Verschraubung in Chemie- und Lebensmittelbetrieben. Die Überwurfmutter und Kegelsutzen werden mit der Schlauchleitung konfektioniert.

Die Überwurfmutter sollte den Kegelschutz schützen. Das Außengewinde mit Dichtung wird an die Rohrleitung geschweißt, somit sind bei MCC-Außengewinde mit Anschweißenden verfügbar.

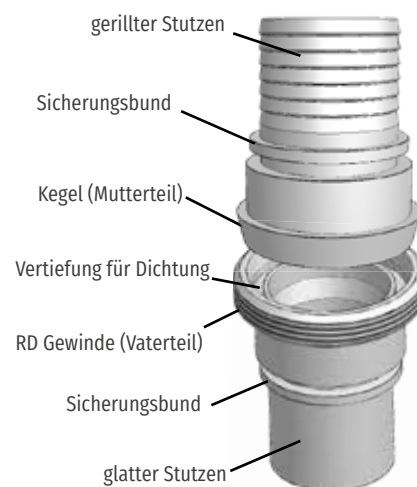



INFORMATION

DIN 11851 Couplings

This fitting series combines two proven standards: the DIN 405-1 thread standard and the DIN 32676 coupling geometry.

A special feature of this fitting is its optimized sealing effect. Thanks to a 5° angle on the sealing surface, only part of the seal is pressed against the fitting. This facilitates the screwing process and at

the same time increases the reliability of the gasket.

This solution has established itself as an almost universal standard under the name "milk pipe fitting". It combines the advantages of a quick coupling with the properties of a robust system. This compensates for the weaknesses of

many DIN EN 14420 quick couplings. This fitting has proved particularly successful with steam hoses in accordance with DIN 6134. Thanks to its sophisticated design, a simple hand tightening is often sufficient to create a reliable connection. A hook wrench to DIN 810 can be used for an even tighter connection.

WHY MCC?

- The threads are cut and tested according to plug gauges
- The fittings are machined from bar stock
- The surfaces comply with hygiene standard H3 correct sealing ring penetration depth and the 5° angle and cone diameter of the coupling part
- The sealing rings are available in different qualities
- All threads are deburred
- The hose supports comply with DIN EN 14420, DIN 14423 and other standards



TECHNICAL INFORMATION

- Norm: DIN 405-1 and DIN 11851
- Sizes: DN25 to DN 100 including cover and plug
- This fitting must not be confused with DIN 11864-1, which has compatible round threads but a different sealing system.
- H3 surface, Ra of 0.8µm
- Heat-Numbers
- Materials: 1.4404 - Nut 1.4301 also PFA lined available
- Adapter variety: S60x6 thread, reducer, ISO 228 IG and AG, elbows, Tri CLamp, SMS, Macon

- Accessories: Impact protection for union Nut, sight glasses

AREA OF APPLICATION

Almost universal fitting in chemical and food processing plants. The union Nut and conical connector are assembled with the hose line.

The union Nut should protect the cone. The external thread with seal is welded to the pipe, so MCC external threads with weld-on ends are available.

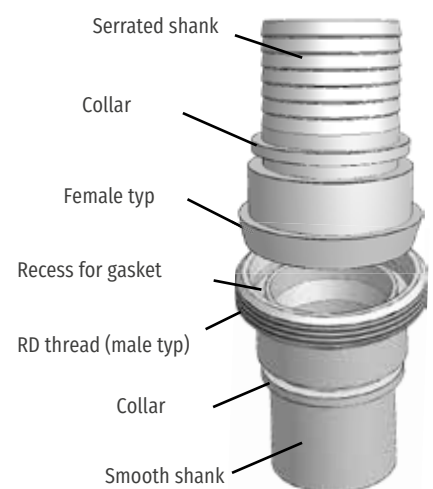



Kegelstutzen nach DIN 11851, mit Rillenstutzen und Sicherungsbund (ohne Überwurfmutter)

Female DIN serrated hose shank with collar (without DIN nut)

Femelle DIN douille annelée à collerette

Hembra DIN con espiga dentada y cuello de seguridad

zęść żeńska - zgodnie DIN 11851 - z karbowaną końcówką do węża z wiązką zabezpieczającą (bez nakrętki)

Bocchettone femmina portagomma DIN 11851 con collare di sicurezza (senza girella)

Part-No.	Material	WP	Dimension	Shank	Price
DINHf15	SS 1.4404	25 bar	DN15	13mm	
DINHf20	SS 1.4404	25 bar	DN20	19mm	
DINHf25	SS 1.4404	25 bar	DN25	25mm	
DINHf32	SS 1.4404	25 bar	DN32	32mm	
DINHf40-38	SS 1.4404	25 bar	DN40	38mm	
DINHf40	SS 1.4404	25 bar	DN40	40mm	
DINHf50	SS 1.4404	25 bar	DN50	50mm	
DINHf65	SS 1.4404	25 bar	DN65	63mm	
DINHf80	SS 1.4404	25 bar	DN80	75mm	
DINHf100	SS 1.4404	25 bar	DN100	100mm	



Kegelstutzen nach DIN 11851, mit Rillenstutzen und Sicherungsbund

ohne Überwurfmutter - PFA ausgekleidet

Female DIN serrated hose shank with collar (without DIN nut) - PFA coated

Femelle DIN douille annelée à collerette - Revêtu de PFA

Hembra DIN con espiga dentada y cuello de seguridad - Recubierto de PFA

zęść Żeńska - zgodnie DIN 11851 - z karbowaną końcówką do węża z wiązką zabezpieczającą (bez nakrętki) - Z powłoką PFA

Bocchettone femmina portagomma DIN 11851 con collare di sicurezza (senza girella) - Rivestimento in PFA

NEW

Part-No.	Material	WP	Dimension	Shank	Price
DINHF25PFA-W	SS 1.4404 PFA white coated	16 bar	DN25	25mm	
DINHF32PFA-W	SS 1.4404 PFA white coated	16 bar	DN32	32mm	
DINHF40-38PFA-W	SS 1.4404 PFA white coated	16 bar	DN40	38mm	
DINHF50PFA-W	SS 1.4404 PFA white coated	16 bar	DN50	50mm	
DINHF65PFA-W	SS 1.4404 PFA white coated	16 bar	DN65	63mm	
DINHF80PFA-W	SS 1.4404 PFA white coated	16 bar	DN80	75mm	
DINHF25PFA-B	SS 1.4404 PFA black coated	16 bar	DN25	25mm	
DINHF32PFA-B	SS 1.4404 PFA black coated	16 bar	DN32	32mm	
DINHF40-38PFA-B	SS 1.4404 PFA black coated	16 bar	DN40	38mm	
DINHF50PFA-B	SS 1.4404 PFA black coated	16 bar	DN50	50mm	
DINHF65PFA-B	SS 1.4404 PFA black coated	16 bar	DN65	63mm	
DINHF80PFA-B	SS 1.4404 PFA black coated	16 bar	DN80	75mm	



CONDUCTIVE



Kegelstutzen nach DIN 11851, mit glattem Stutzen und Sicherungsbund (ohne Überwurfmutter)

Female DIN smooth hose shank with collar (without DIN nut)

Femelle DIN douille lisse à collerette

Hembra din con espiga lisa y cuello de seguridad - sin junta

Część żeńska zgodnie DIN 11851 z gładką końcówką do węża z wiązką zabezpieczającą (bez nakrętki)

Bocchettone femmina portagomma liscio DIN 11851 con collare di sicurezza (senza girella)

Part-No.	Material	WP	Dimension	Shank	Price
DINHf15SM	SS 1.4404	25 bar	DN15	13mm	
DINHf20SM	SS 1.4404	25 bar	DN20	19mm	
DINHf25SM	SS 1.4404	25 bar	DN25	25mm	
DINHf32SM	SS 1.4404	25 bar	DN32	32mm	
DINHf40-38SM	SS 1.4404	25 bar	DN40	38mm	
DINHf40SM	SS 1.4404	25 bar	DN40	40mm	
DINHf50SM	SS 1.4404	25 bar	DN50	50mm	
DINHf65SM	SS 1.4404	25 bar	DN65	63mm	
DINHf80SM	SS 1.4404	25 bar	DN80	75mm	
DINHf100SM	SS 1.4404	25 bar	DN100	100mm	



Außengewindestutzen nach DIN 11851 mit Rillenstutzen und Sicherungsbund (ohne Dichtung)

Male DIN serrated hose shank with collar - without gasket

Mâle DIN douille annelée à collerette - sans joint

Macho din con espiga dentada y cuello de seguridad - sin junta

Część Męska z gwintem zewnętrznym zgodnie DIN 11851 z karbowaną końcówką do węża z wiązką zabezpieczającą (bez uszczelki)

Bocchettone maschio portagomma a resca DIN 11851 con collare di sicurezza (senza guarnizione)



Part-No.	Material	WP	Dimension	Shank	Price
DINH15	SS 1.4404	25 bar	DN15	13mm	
DINH20	SS 1.4404	25 bar	DN20	19mm	
DINH25	SS 1.4404	25 bar	DN25	25mm	
DINH32	SS 1.4404	25 bar	DN32	32mm	
DINH40-38	SS 1.4404	25 bar	DN40	38mm	
DINH40	SS 1.4404	25 bar	DN40	40mm	
DINH50	SS 1.4404	25 bar	DN50	50mm	
DINH65	SS 1.4404	25 bar	DN65	63mm	
DINH80	SS 1.4404	25 bar	DN80	75mm	
DINH100	SS 1.4404	25 bar	DN100	100mm	



Außengewindestutzen nach DIN 11851 mit Rillenstutzen und Sicherungsbund
(ohne Dichtung) - PFA ausgekleidet

Male DIN serrated hose shank with collar - without gasket - PFA coated

Mâle DIN douille annelée à collerette - sans joint - Revêtu de PFA

Macho din con espiga dentada y cuello de seguridad - sin junta - Recubierto de PFA

Część Męska z gwintem zewnętrznym zgodnie DIN 11851 z karbowaną końcówką do węża z wiązką zabezpieczającą (bez uszczelki)

Bocchettone maschio portagomma liscio DIN 11851 con collare di sicurezza (senza guarnizione) - Rivestimento in PFA

NEW



CONDUCTIVE

Part-No.	Material	WP	Couping	Shank	Price
DINHM25PFA-W	SS 1.4404 PFA white coated	16 bar	DN25	25mm	
DINHM32PFA-W	SS 1.4404 PFA white coated	16 bar	DN32	32mm	
DINHM40-38PFA-W	SS 1.4404 PFA white coated	16 bar	DN40	38mm	
DINHM50PFA-W	SS 1.4404 PFA white coated	16 bar	DN50	50mm	
DINHM65PFA-W	SS 1.4404 PFA white coated	16 bar	DN65	63mm	
DINHM80PFA-W	SS 1.4404 PFA white coated	16 bar	DN80	75mm	
DINHM25PFA-B	SS 1.4404 PFA black coated	16 bar	DN25	25mm	
DINHM32PFA-B	SS 1.4404 PFA black coated	16 bar	DN32	32mm	
DINHM40-38PFA-B	SS 1.4404 PFA black coated	16 bar	DN40	38mm	
DINHM50PFA-B	SS 1.4404 PFA black coated	16 bar	DN50	50mm	
DINHM65PFA-B	SS 1.4404 PFA black coated	16 bar	DN65	63mm	
DINHM80PFA-B	SS 1.4404 PFA black coated	16 bar	DN80	75mm	



Außengewindestutzen nach DIN 11851 mit glattem Stutzen und Sicherungsbund (ohne Dichtung)

Male DIN smooth hose shank with collar - without gasket

Mâle DIN douille lisse à collerette - sans joint

Macho DIN con espiga lisa y cuello de seguridad - sin junta

Część Męska z gwintem zewnętrznym zgodnie DIN 11851 z gładką końcówką do węża z wiązką zabezpieczającą (bez uszczelki)

Bocchettone maschio portagomma liscio DIN 11851 con collare di sicurezza (senza guarnizione)



Part-No.	Material	WP	Dimension	Shank	Price
DINH15SM	SS 1.4404	25 bar	DN15	13mm	
DINH20SM	SS 1.4404	25 bar	DN20	19mm	
DINH25SM	SS 1.4404	25 bar	DN25	25mm	
DINH32SM	SS 1.4404	25 bar	DN32	32mm	
DINH40-38SM	SS 1.4404	25 bar	DN40	38mm	
DINH40SM	SS 1.4404	25 bar	DN40	40mm	
DINH50SM	SS 1.4404	25 bar	DN50	50mm	
DINH65SM	SS 1.4404	25 bar	DN65	63mm	
DINH80SM	SS 1.4404	25 bar	DN80	75mm	
DINH100SM	SS 1.4404	25 bar	DN100	100mm	





45° Kegelstutzen nach DIN 11851, mit Rillenstutzen und Sicherungsbund
(mit Überwurfmutter)

45° Female DIN serrated hose shank with collar (with DIN nut)

45° Femelle DIN douille annelée à collerette

45° Hembra DIN con espiga dentada y cuello de seguridad (tuerca DIN)

45° Część Żeńska - zgodnie DIN 11851 - z karbowaną końcówką do węża z wiązką zabezpieczającą (nakrętka)

45° femmina DIN con portagomma (Girella DIN)

Part-No.	Material	WP	Dimension	Shank	Price
DINHF20-45	SS 1.4404	25 bar	DN20	19mm	
DINHF25-45	SS 1.4404	25 bar	DN25	25mm	
DINHF32-45	SS 1.4404	25 bar	DN32	32mm	
DINHF40-38-45	SS 1.4404	25 bar	DN40	38mm	
DINHF40-45	SS 1.4404	25 bar	DN40	40mm	
DINHF50-45	SS 1.4404	25 bar	DN50	50mm	
DINHF65-45	SS 1.4404	25 bar	DN65	63mm	
DINHF80-45	SS 1.4404	25 bar	DN80	75mm	



45° Außengewindestutzen nach DIN 11851 mit Rillenstutzen
und Sicherungsbund (ohne Dichtung)

45° Male DIN serrated hose shank with collar - (without gasket)

45° Mâle DIN douille annelée à collerette - sans joint

45° Macho DIN con espiga dentada y cuello de seguridad - sin junta

45° Część Męska z gwintem zewnętrznym zgodnie DIN 11851 z karbowaną końcówką do węża z wiązką zabezpieczającą (bez uszczelki)

45° Maschio DIN portagomma a resca e collare di sicurezza - senza guarnizione

Part-No.	Material	WP	Dimension	Shank	Price
DINHM20-45	SS 1.4404	25 bar	DN20	19mm	
DINHM25-45	SS 1.4404	25 bar	DN25	25mm	
DINHM32-45	SS 1.4404	25 bar	DN32	32mm	
DINHM40-38-45	SS 1.4404	25 bar	DN40	38mm	
DINHM40-45	SS 1.4404	25 bar	DN40	40mm	
DINHM50-45	SS 1.4404	25 bar	DN50	50mm	
DINHM65-45	SS 1.4404	25 bar	DN65	63mm	
DINHM80-45	SS 1.4404	25 bar	DN80	75mm	



90° Kegelstutzen nach DIN 11851, mit Rillenstutzen und Sicherungsbund (mit Überwurfmutter)

90° Female DIN serrated hose shank with collar (with DIN nut)

90° Femelle DIN douille annelée à collerette (avec écrou DIN)

90° Hembra DIN con espiga dentada y cuello de seguridad (tuerca DIN)

90° Część żeńska - zgodnie DIN 11851 - z karbowaną końcówką do węża z wiązką zabezpieczającą (nakrętka)

90° Femmina DIN portagomma con collare di sicurezza (Girella DIN)



Part-No.	Material	WP	Dimension	Shank	Price
DINHF20-90	SS 1.4404	25 bar	DN20	19mm	
DINHF25-90	SS 1.4404	25 bar	DN25	25mm	
DINHF32-90	SS 1.4404	25 bar	DN32	32mm	
DINHF40-38-90	SS 1.4404	25 bar	DN40	38mm	
DINHF40-90	SS 1.4404	25 bar	DN40	40mm	
DINHF50-90	SS 1.4404	25 bar	DN50	50mm	
DINHF65-90	SS 1.4404	25 bar	DN65	63mm	
DINHF80-90	SS 1.4404	25 bar	DN80	75mm	

90° Außengewindestutzen nach DIN 11851 mit Rillenstutzen und Sicherungsbund (ohne Dichtung)

90° Male DIN serrated hose shank with collar - (without gasket)

90° Mâle DIN douille annelée à collerette - sans joint

90° Macho DIN con espiga dentada y cuello de seguridad - sin junta

90° Część Męska z gwintem zewnętrznym zgodnie DIN 11851 z karbowaną końcówką do węża z wiązką zabezpieczającą (bez uszczelki)

90° Maschio DIN portagomma a resca e collare di sicurezza - senza guarnizione



Part-No.	Material	WP	Dimension	Shank	Price
DINHM20-90	SS 1.4404	25 bar	DN20	19mm	
DINHM25-90	SS 1.4404	25 bar	DN25	25mm	
DINHM32-90	SS 1.4404	25 bar	DN32	32mm	
DINHM40-38-90	SS 1.4404	25 bar	DN40	38mm	
DINHM40-90	SS 1.4404	25 bar	DN40	40mm	
DINHM50-90	SS 1.4404	25 bar	DN50	50mm	
DINHM65-90	SS 1.4404	25 bar	DN65	63mm	
DINHM80-90	SS 1.4404	25 bar	DN80	75mm	





Kegelstutzen nach DIN 11851, für Schelleneinband

(ohne Überwurfmutter)

Female DIN with hose shank for clamps (without DIN nut)

Femelle DIN douille annelée sans collerette

Hembra DIN 11851 con espiga para abrazaderas (sin tuerca DIN)

Część Żeńska zgodnie DIN 11851 - z końcówką do węża do mocowania opaskami (bez nakrętki)

Femmina DIN 11851 portagomma per semigusci - senza girella

Part-No.	Material	WP	Dimension	Shank	Price
DINHF25BT	SS 1.4404	25 bar	DN25	25mm	
DINHF32BT	SS 1.4404	25 bar	DN32	32mm	
DINHF40BT	SS 1.4404	25 bar	DN40	40mm	
DINHF50BT	SS 1.4404	25 bar	DN50	50mm	
DINHF65BT	SS 1.4404	25 bar	DN65	63mm	
DINHF80BT	SS 1.4404	25 bar	DN80	75mm	
DINHF100BT	SS 1.4404	25 bar	DN100	100mm	



Vaterteilstutzen nach DIN 11851 für Schelleneinband

(ohne Dichtung)

Male DIN with hose shank for clamps - without gasket

Mâle DIN douille annelée sans collerette - sans joint

Macho DIN con espiga para abrazaderas - sin junta

Część Męska z gwintem zewnętrznym zgodnie DIN 11851 z końcówką do węża do mocowania opaskami - bez uszczelki

Maschio DIN 11851 portagomma per semigusci - senza guarnizione

Part-No.	Material	WP	Dimension	Shank	Price
DINH25BT	SS 1.4404	25 bar	DN25	25mm	
DINH32BT	SS 1.4404	25 bar	DN32	32mm	
DINH40BT	SS 1.4404	25 bar	DN40	40mm	
DINH50BT	SS 1.4404	25 bar	DN50	50mm	
DINH65BT	SS 1.4404	25 bar	DN65	63mm	
DINH80BT	SS 1.4404	25 bar	DN80	75mm	
DINH100BT	SS 1.4404	25 bar	DN100	100mm	



Kegelstutzen nach DIN 11851 mit Anschweißende

(ohne Überwurfmutter)

Female DIN with welding end (without DIN nut)

Femelle DIN à souder

Casquillo hembra DIN 11851 para soldar

Część żeńska zgodnie DIN 11851 z króćcem do dospawania (bez nakrętki)

Bocchettone DIN femmina a saldare



Part-No.	Material	WP	Dimension	BW (IDxOD)	Price
DINHf20BW	SS 1.4404	25 bar	DN20	20 x 24	
DINHf25BW	SS 1.4404	25 bar	DN25	26 x 29	
DINHf32BW	SS 1.4404	25 bar	DN32	32 x 35	
DINHf40BW	SS 1.4404	25 bar	DN40	38 x 41	
DINHf50BW	SS 1.4404	25 bar	DN50	50 x 53	
DINHf65BW	SS 1.4404	25 bar	DN65	66 x 70	
DINHf80BW	SS 1.4404	25 bar	DN80	81 x 85	
DINHf100BW	SS 1.4404	25 bar	DN100	100 x 104	

Außengewinde nach DIN 11851 mit Anschweißende (BW)

(ohne Dichtung)

Male DIN with welding end (without gasket)

Mâle DIN à souder

Casquillo macho DIN 11851 para soldar (sin junta)

Część męska z gwintem zewnętrznym zgodnie DIN 11851 z króćcem do spawania (bez uszczelki)

Bocchettone DIN maschio a saldare



Part-No.	Material	WP	Dimension	BW (IDxOD)	Price
DINHm20BW	SS 1.4404	25 bar	DN20	20 x 24	
DINHm25BW	SS 1.4404	25 bar	DN25	26 x 29	
DINHm32BW	SS 1.4404	25 bar	DN32	32 x 35	
DINHm40BW	SS 1.4404	25 bar	DN40	38 x 41	
DINHm50BW	SS 1.4404	25 bar	DN50	50 x 53	
DINHm65BW	SS 1.4404	25 bar	DN65	66 x 70	
DINHm80BW	SS 1.4404	25 bar	DN80	81 x 85	
DINHm100BW	SS 1.4404	25 bar	DN100	100 x 104	





45° Kegelstutzen nach DIN 11851 mit Anschweißende (BW)

mit montierter Überwurfmutter (SS 1.4301)

DIN 11851 45° elbow, female - with assembled nut (SS 1.4301) - to welding end

DIN Coude 45° - Femelle avec écrou - à souder

Hembra con tuerca DIN 11851 con extremo para soldar - Codo 45°

Część Żeńska z nakrętką (SS 1.4301) z 45° Kolanem i z króćcem do dospawania

Curva 45° con raccordo DIN femmina - estremo da saldare

Part-No.	Material	WP	Dimension	BW (IDxOD)	Price
DINHf20BW-45	SS 1.4404	25 bar	DN20	20 x 24	
DINHf25BW-45	SS 1.4404	25 bar	DN25	26 x 29	
DINHf32BW-45	SS 1.4404	25 bar	DN32	32 x 35	
DINHf40BW-45	SS 1.4404	25 bar	DN40	38 x 41	
DINHf50BW-45	SS 1.4404	25 bar	DN50	50 x 53	
DINHf65BW-45	SS 1.4404	25 bar	DN65	66 x 70	
DINHf80BW-45	SS 1.4404	25 bar	DN80	81 x 85	



45° Außengewinde nach DIN 11851 mit Anschweißende (BW)

(ohne Dichtung)

Male DIN with welding end (without gasket) - 45°

Mâle DIN à souder - 45°

Macho DIN 11851 con extremo para soldar - Codo 45°

Część Męska z gwintem zewnętrznym zgodnie DIN 11851 z króćcem do spawania (bez uszczelki) - 45°

Curva 45° con raccordo DIN maschio - estremo da saldare

Part-No.	Material	WP	Dimension	BW (IDxOD)	Price
DINHm20BW-45	SS 1.4404	25 bar	DN20	20 x 24	
DINHm25BW-45	SS 1.4404	25 bar	DN25	26 x 29	
DINHm32BW-45	SS 1.4404	25 bar	DN32	32 x 35	
DINHm40BW-45	SS 1.4404	25 bar	DN40	38 x 41	
DINHm50BW-45	SS 1.4404	25 bar	DN50	50 x 53	
DINHm65BW-45	SS 1.4404	25 bar	DN65	66 x 70	
DINHm80BW-45	SS 1.4404	25 bar	DN80	81 x 85	



90° Kegelstutzen nach DIN 11851 mit Anschweißende (BW)

mit montierter Überwurfmutter (SS 1.4301)

DIN 11851 90° elbow, female - with assembled nut (SS 1.4301) - to welding end

DIN Coude 90° - Femelle avec écrou - à souderr

Hembra con tuerca DIN 11851 con extremo para soldar - Codo 90°

Część Żeńska z nakrętką (SS 1.4301) z 90° Kolanem i z króćcem do dospawania

Curva 90° con raccordo DIN femmina - estremo da saldare



Part-No.	Material	WP	Dimension	BW (IDxOD)	Price
DINHF20BW-90	SS 1.4404	25 bar	DN20	20 x 24	
DINHF25BW-90	SS 1.4404	25 bar	DN25	26 x 29	
DINHF32BW-90	SS 1.4404	25 bar	DN32	32 x 35	
DINHF40BW-90	SS 1.4404	25 bar	DN40	38 x 41	
DINHF50BW-90	SS 1.4404	25 bar	DN50	50 x 53	
DINHF65BW-90	SS 1.4404	25 bar	DN65	66 x 70	
DINHF80BW-90	SS 1.4404	25 bar	DN80	81 x 85	

90° Außengewinde nach DIN 11851 mit Anschweißende (BW)

(ohne Dichtung)

Male DIN with welding end (without gasket) - 90°

DIN Coude 90° - Mâle - à souder

Macho DIN 11851 con extremo para soldar - Codo 90°

Część Męska z gwintem zewnętrznym (bez uszczelki) z 90° Kolanem i z króćcem do dospawania

Curva 90° con raccordo DIN maschio - estremo da saldare



Part-No.	Material	WP	Dimension	BW (IDxOD)	Price
DINH20BW-90	SS 1.4404	25 bar	DN20	20 x 24	
DINH25BW-90	SS 1.4404	25 bar	DN25	26 x 29	
DINH32BW-90	SS 1.4404	25 bar	DN32	32 x 35	
DINH40BW-90	SS 1.4404	25 bar	DN40	38 x 41	
DINH50BW-90	SS 1.4404	25 bar	DN50	50 x 53	
DINH65BW-90	SS 1.4404	25 bar	DN65	66 x 70	
DINH80BW-90	SS 1.4404	25 bar	DN80	81 x 85	





Schauglas DIN 11851 mit Anschweißende (BW)

Sight glass DIN with welding end
 Regard vissé DIN 11851 DIN à souder
 Tuerca DIN 11851 con visor para soldar
 Wziernik DIN 11851 z króćcem do spawania
 Girella con mirino DIN a saldare

Part-No.	Material	WP	Dimension	BW (IDxOD)	Price
DINSG25BW	SS 1.4404	25 bar	DN25	26 x 29	
DINSG32BW	SS 1.4404	25 bar	DN32	32 x 35	
DINSG40BW	SS 1.4404	25 bar	DN40	38 x 41	
DINSG50BW	SS 1.4404	25 bar	DN50	48 x 50	
DINSG65BW	SS 1.4404	25 bar	DN65	66 x 70	
DINSG80BW	SS 1.4404	25 bar	DN80	81 x 85	
DINSG100BW	SS 1.4404	25 bar	DN100	100 x 104	



Schauglas aus Borosilikatglas mit beidseitigem DIN Anschweißende

Montierte Schutzstäbe aus SS 1.4301
 Tubular sight glass DIN with welding ends, borosilicate glass
 Viseur tubulaire DIN avec extrémités à souder verre borosilicate
 Mirilla tubular DIN con extremos para soldar, vidrio borosilicatado
 Wziernik wykonany ze szkła borokrzemowego z obustronną końcówką do spawania DIN
 Specola di Linea con attacchi DIN con estremità a saldare, vetro borosilicato

Part-No.	Material	WP	Dimension	BW (IDxOD)	Price
DINBW25BW25-SG	borosilicate / 1.4404	25 bar	DN25	26 x 29	
DINBW32BW32-SG	borosilicate / 1.4404	25 bar	DN32	32 x 35	
DINBW40BW40-SG	borosilicate / 1.4404	25 bar	DN40	38 x 41	
DINBW50BW50-SG	borosilicate / 1.4404	25 bar	DN50	48 x 50	
DINBW65BW65-SG	borosilicate / 1.4404	25 bar	DN65	66 x 70	
DINBW80BW80-SG	borosilicate / 1.4404	25 bar	DN80	81 x 85	
DINBW100BW100-SG	borosilicate / 1.4404	25 bar	DN100	100 x 104	

LEBENSMITTELINDUSTRIE



Schauglas aus Borosilikatglas mit beidseitigem Außengewinde nach DIN 11851

Montierte Schutzstäbe aus SS 1.4301

Tubular sight glass DIN with both sides male, borosilicate glass

Viseur tubulaire DIN avec extrémités mâles, verre borosilicate

Mirilla tubular DIN macho - macho, vidrio borosilicatado

Wziernik wykonany ze szkła borokrzemowego z gwintem zewnętrznym DIN

Specola di Linea con attacchi DIN maschio - maschio, vetro borosilicato



Part-No.	Material	WP	Dimension	Dimension	Price
DINH25HM25-SG	borosilicate / 1.4404	25 bar	DN25	DN25	
DINH32HM32-SG	borosilicate / 1.4404	25 bar	DN32	DN32	
DINH40HM40-SG	borosilicate / 1.4404	25 bar	DN40	DN40	
DINH50HM50-SG	borosilicate / 1.4404	25 bar	DN50	DN50	
DINH65HM65-SG	borosilicate / 1.4404	25 bar	DN65	DN65	
DINH80HM80-SG	borosilicate / 1.4404	25 bar	DN80	DN80	
DINH100HM100-SG	borosilicate / 1.4404	25 bar	DN100	DN100	

Ersatz Schutzgitter für Lebensmittelschaugläser

Replacement net case for sight glass

Filet de remplacement pour le verre de regard

Funda de red de repuesto para mirilla

Wymienna obudowa siatki do wziernika

Custodia di ricambio in rete per il vetro spia



Part-No.	Material	Dimension	Price
REPCASE1-SG	SS 1.4301	DN25	
REPCASE1.25-SG	SS 1.4301	DN32	
REPCASE1.5-SG	SS 1.4301	DN40	
REPCASE2-SG	SS 1.4301	DN50	
REPCASE2.5-SG	SS 1.4301	DN65	
REPCASE3-SG	SS 1.4301	DN80	
REPCASE4-SG	SS 1.4301	DN100	





DIN 11851 - Außengewinde auf Außengewinde

DIN male to DIN male
 DIN - Mâle
 DIN 11851 macho - macho
 DIN 11851 - obie strony Część Męska z gwintem zewnętrznym
 Bocchettone adattatore maschio-maschio DIN 11851o

Part-No.	Material	WP	Male	Male	Price
DINH20HM20	SS 1.4404	25 bar	DN20	DN20	
DINH25HM25	SS 1.4404	25 bar	DN25	DN25	
DINH32HM32	SS 1.4404	25 bar	DN32	DN32	
DINH40HM40	SS 1.4404	25 bar	DN40	DN40	
DINH50HM50	SS 1.4404	25 bar	DN50	DN50	
DINH65HM65	SS 1.4404	25 bar	DN65	DN65	
DINH80HM80	SS 1.4404	25 bar	DN80	DN80	



Reduzierung DIN 11851 - Kegelstutzen mit Überwurfmutter (SS 1.4301)
 auf Außengewinde

DIN reducer - DIN female with nut to DIN male
 Réduction DIN - Femelle avec écrou - Mâle
 Reducción DIN 11851 hembra con tuerca - macho
 Redukcja DIN 11851 - Część Żeńska z nakrętką na Część Męską z gwintem zewnętrznym
 Bocchettone ridotto femmina con girella - maschio DIN 11851

Part-No.	Material	WP	Nut	Male	Price
DINH25HM20	SS 1.4404	25 bar	DN25	DN20	
DINH32HM25	SS 1.4404	25 bar	DN32	DN25	
DINH40HM25	SS 1.4404	25 bar	DN40	DN25	
DINH40HM32	SS 1.4404	25 bar	DN40	DN32	
DINH50HM40	SS 1.4404	25 bar	DN50	DN40	
DINH80HM50	SS 1.4404	25 bar	DN80	DN50	

LEBENSMITTELINDUSTRIE



Reduzierung DIN 11851 - Außengewinde auf Außengewinde

DIN Reducer - DIN male to DIN male

Réduction DIN - Mâle

Reducción DIN 11851 macho - macho

Redukcja DIN 11851 - obie strony Część Męska z gwintem zewnętrznym

Bocchettone ridotto maschio-maschio DIN 11851



Part-No.	Material	WP	Male	Male	Price
DINH32HM25	SS 1.4404	25 bar	DN32	DN25	
DINH40HM25	SS 1.4404	25 bar	DN40	DN25	
DINH40HM32	SS 1.4404	25 bar	DN40	DN32	
DINH50HM40	SS 1.4404	25 bar	DN50	DN40	

Reduzierung DIN 11851 - Kegeltutzen mit Überwurfmutter

auf Kegeltutzen mit Überwurfmutter (SS 1.4301)

DIN reducer - DIN female with nut to DIN female with nut

Réduction DIN - Femelle avec Erou

Reducción DIN 11851 hembra con tuerca - hembra con tuerca

Redukcja DIN 11851 - obie strony Część Żeńska z nakrętką

Bocchettone ridotto femmina con girella - femmina con girella DIN 11851



Part-No.	Material	WP	Nut	Nut	Price
DINH32HF25	SS 1.4404	25 bar	DN32	DN25	
DINH40HF25	SS 1.4404	25 bar	DN40	DN25	
DINH40HF32	SS 1.4404	25 bar	DN40	DN32	
DINH50HF40	SS 1.4404	25 bar	DN50	DN40	





Reduzierung DIN 11851 - Außengewinde auf Kegelstutzen
mit Überwurfmutter (SS 1.4301)

DIN reducer - DIN male to DIN female with nut
Réduction DIN - Mâle - Femelle avec écrou
Reducción DIN 11851 macho - hembra con tuerca
Redukcja DIN 11851 - Część Męska z gwintem zewnętrznym na Część Żeńską z nakrętką
Bocchettone ridotto maschio - femmina con girella DIN 11851

Part-No.	Material	WP	Male	Nut	Price
DINHM32HF25	SS 1.4404	25 bar	DN32	DN25	
DINHM40HF25	SS 1.4404	25 bar	DN40	DN25	
DINHM40HF32	SS 1.4404	25 bar	DN40	DN32	
DINHM50HF40	SS 1.4404	25 bar	DN50	DN40	



Übergangsstück Kegelseutzen DIN 11851 mit Überwurfmutter
auf BSPP Innengewinde - ohne Gewindedichtung

Adapter DIN female with nut to BSPP female thread - without thread gasket
Adaptateur DIN femelle avec écrou - Taraudage femelle BSPP - sans joint de filetage
DIN 11851 hembra con tuerca - rosca hembra BSPP - sin junta rosca PTFE
Adapter DIN 11851 - Część Żeńska z nakrętką na końcówkę z gwintem wewnętrznym BSPP - bez uszczelką gwintowaną
DIN 11851 Bocchettone femmina con girella - femmina BSPP - senza guarnizione

Part-No.	Material	WP	Dimension	Thread	Price
DINHF15IG	SS 1.4404	25 bar	DN15	1/2"	
DINHF20IG	SS 1.4404	25 bar	DN20	3/4"	
DINHF25IG	SS 1.4404	25 bar	DN25	1"	
DINHF32IG	SS 1.4404	25 bar	DN32	1 1/4"	
DINHF40IG	SS 1.4404	25 bar	DN40	1 1/2"	
DINHF50IG	SS 1.4404	25 bar	DN50	2"	



Übergangsstück Außengewinde DIN 11851 auf BSPP Innengewinde ohne Gewindedichtung

Adapter DIN male to BSPP female thread - without gasket

Adaptateur DIN Mâle - Taraudage femelle BSPP - sans Jointt

Macho DIN - rosca hembra BSPP - sin junta

Adapter DIN 11851 - Część Męska z gwintem zewnętrznym na końcówkę z gwintem wewnętrznym BSPP - bez uszczelką gwintowaną

Bocchettone maschio DIN 11851 - filettato femmina BSPP- senza guarnizione



Part-No.	Material	WP	Dimension	Thread	Price
DINHM15IG	SS 1.4404	25 bar	DN15	1/2"	
DINHM20IG	SS 1.4404	25 bar	DN20	3/4"	
DINHM25IG	SS 1.4404	25 bar	DN25	1"	
DINHM32IG	SS 1.4404	25 bar	DN32	1 1/4"	
DINHM40IG	SS 1.4404	25 bar	DN40	1 1/2"	
DINHM50IG	SS 1.4404	25 bar	DN50	2"	

Übergangsstück Kegelstutzen DIN 11851 ohne Überwurfmutter auf BSPP Außengewinde

Adapter DIN female without nut to BSPP male thread

Adaptateur DIN Femelle sans écrou - Filetage mâle BSPP

Hembra DIN - rosca macho BSPP

Adapter DIN 11851 - Część Żeńska bez nakrętki na końcówkę z gwintem zewnętrznym BSPP

Adattatore femmina DIN 11851 senza girella con filettatura maschio BSP



Part-No.	Material	WP	Dimension	Thread	Price
DINHf15AG	SS 1.4404	25 bar	DN15	1/2"	
DINHf20AG	SS 1.4404	25 bar	DN20	3/4"	
DINHf25AG	SS 1.4404	25 bar	DN25	1"	
DINHf32AG	SS 1.4404	25 bar	DN32	1 1/4"	
DINHf40AG	SS 1.4404	25 bar	DN40	1 1/2"	
DINHf50AG	SS 1.4404	25 bar	DN50	2"	





Übergangsstück Außengewinde DIN 11851 auf BSPP Außengewinde

Adapter DIN male to BSPP male thread

Adaptateur DIN Mâle - Filetage mâle BSPP

Macho DIN - rosca macho BSPP

Adapter DIN 11851 - Część Męska z gwintem zewnętrznym na końcówkę z gwintem zewnętrznym BSPP

Adattatore femmina DIN 11851 senza girella con filettatura maschio BSP

Part-No.	Material	WP	Dimension	Thread	Price
DINH15AG	SS 1.4404	25 bar	DN15	1/2"	
DINH20AG	SS 1.4404	25 bar	DN20	3/4"	
DINH25AG	SS 1.4404	25 bar	DN25	1"	
DINH32AG	SS 1.4404	25 bar	DN32	1 1/4"	
DINH40AG	SS 1.4404	25 bar	DN40	1 1/2"	
DINH50AG	SS 1.4404	25 bar	DN50	2"	



Milchrohrbogen 45°, beidseitig Kegelstutzen nach DIN 11851

mit montierter Überwurfmutter (SS 1.4301)

DIN 11851 45° elbow, both sides female - assembled with nut (SS 1.4301)

DIN Coude 45° - Femelle avec écrou - Femelle avec écrou (SS 1.4301)

Codo 45° - Hembra DIN a hembra DIN - con tuerca (SS 1.4301)

45° Kolano obustronny Część Żeńska z nakrętką (SS 1.4301)

Curva 45° DIN - Femmina DIN a Femmina DIN - con girella (SS 1.4301)

Part-No.	Material	WP	Nut	Nut	Price
DINH20HF20-45	SS 1.4404	25 bar	DN20	DN20	
DINH25HF25-45	SS 1.4404	25 bar	DN25	DN25	
DINH32HF32-45	SS 1.4404	25 bar	DN32	DN32	
DINH40HF40-45	SS 1.4404	25 bar	DN40	DN40	
DINH50HF50-45	SS 1.4404	25 bar	DN50	DN50	
DINH65HF65-45	SS 1.4404	25 bar	DN65	DN65	
DINH80HF80-45	SS 1.4404	25 bar	DN80	DN80	



Milchrohrbogen 45°, beidseitig Außengewinde nach DIN 11851

(ohne Dichtung)

DIN 11851 45° elbow, both sides male thread (without gasket)

DIN Coude 45° - Mâle - Mâle

Codo 45° - Macho DIN a macho DIN

45° Kolano obustronny Część Męska z gwintem zewnętrznym (bez uszczelki)

Curva 45° DIN - Maschio DIN a maschio DIN



Part-No.	Material	WP	Male	Male	Price
DINHM20HM20-45	SS 1.4404	25 bar	DN20	DN20	
DINHM25HM25-45	SS 1.4404	25 bar	DN25	DN25	
DINHM32HM32-45	SS 1.4404	25 bar	DN32	DN32	
DINHM40HM40-45	SS 1.4404	25 bar	DN40	DN40	
DINHM50HM50-45	SS 1.4404	25 bar	DN50	DN50	
DINHM65HM65-45	SS 1.4404	25 bar	DN65	DN65	
DINHM80HM80-45	SS 1.4404	25 bar	DN80	DN80	

Milchrohrbogen 45°, Kegelstutzen nach DIN 11851

mit montierter Überwurfmutter (SS 1.4301) auf DIN Außengewinde

DIN 11851 45° elbow, female with assembled nut (SS 1.4301) to male thread

DIN Coude 45° - Femelle avec écrou - Mâle

Codo 45° - Hembra DIN con tuerca a Macho DIN

Część Żeńska z nakrętką (SS 1.4301) z 45° Kolanem na Część Męską z gwintem zewnętrznym (bez uszczelki)

Curva 45° DIN - Femmina DIN con girela a Maschio DIN



Part-No.	Material	WP	Nut	Male	Price
DINHf20HM20-45	SS 1.4404	25 bar	DN20	DN20	
DINHf25HM25-45	SS 1.4404	25 bar	DN25	DN25	
DINHf32HM32-45	SS 1.4404	25 bar	DN32	DN32	
DINHf40HM40-45	SS 1.4404	25 bar	DN40	DN40	
DINHf50HM50-45	SS 1.4404	25 bar	DN50	DN50	
DINHf65HM65-45	SS 1.4404	25 bar	DN65	DN65	
DINHf80HM80-45	SS 1.4404	25 bar	DN80	DN80	





Milchrohrbogen 90°, beidseitig Kegelstutzen nach DIN 11851

mit montierter Überwurfmutter (SS 1.4301)

DIN 11851 90° elbow, both sides female - assembled with nut (SS 1.4301)

DIN Coude 90° - Femelle avec écrou - Femelle avec écrou (SS 1.4301)

Codo 90° DIN - Hembra DIN a Hembra DIN - con tuerca (SS 1.4301)

90° Kolano obustronny Część Żeńska z nakrętką (SS 1.4301)

Curva 90° DIN - Femmina DIN a Femmina DIN- con girella (SS 1.4301)

Part-No.	Material	WP	Nut	Nut	Price
DINHF20HF20-90	SS 1.4404	25 bar	DN20	DN20	
DINHF25HF25-90	SS 1.4404	25 bar	DN25	DN25	
DINHF32HF32-90	SS 1.4404	25 bar	DN32	DN32	
DINHF40HF40-90	SS 1.4404	25 bar	DN40	DN40	
DINHF50HF50-90	SS 1.4404	25 bar	DN50	DN50	
DINHF65HF65-90	SS 1.4404	25 bar	DN65	DN65	
DINHF80HF80-90	SS 1.4404	25 bar	DN80	DN80	



Milchrohrbogen 90°, beidseitig Außengewinde nach DIN 11851

(ohne Dichtung)

DIN 11851 90° elbow, both sides male thread (without gasket)

DIN Coude 90° - Mâle - Mâle

Codo 90° DIN - Macho DIN a macho DIN

90° Kolano obustronny Część Męska z gwintem zewnętrznym (bez uszczelki)

Curva 90° DIN - Maschio DIN a Maschio DIN

Part-No.	Material	WP	Male	Male	Price
DINHM20HM20-90	SS 1.4404	25 bar	DN20	DN20	
DINHM25HM25-90	SS 1.4404	25 bar	DN25	DN25	
DINHM32HM32-90	SS 1.4404	25 bar	DN32	DN32	
DINHM40HM40-90	SS 1.4404	25 bar	DN40	DN40	
DINHM50HM50-90	SS 1.4404	25 bar	DN50	DN50	
DINHM65HM65-90	SS 1.4404	25 bar	DN65	DN65	
DINHM80HM80-90	SS 1.4404	25 bar	DN80	DN80	



Milchrohrbogen 90°, Kegelstutzen nach DIN 11851

mit montierter Überwurfmutter (SS 1.4301) auf DIN Außengewinde



DIN 11851 90° elbow, female with assembled nut (SS 1.4301) to male thread

DIN Coude 90° - Femelle avec écrou - Mâle

Codo90° DIN - Hembra DIN con tuerca a macho DIN

Część Żeńska z nakrętką (SS 1.4301) z 90° Kolanem na Część Męską z gwintem zewnętrznym (bez uszczelki)

Curva 90° DIN - Femmina DIN con girilla a filettatura a Maschio DIN

Part-No.	Material	WP	Nut	Male	Price
DINHF20HM20-90	SS 1.4404	25 bar	DN20	DN20	
DINHF25HM25-90	SS 1.4404	25 bar	DN25	DN25	
DINHF32HM32-90	SS 1.4404	25 bar	DN32	DN32	
DINHF40HM40-90	SS 1.4404	25 bar	DN40	DN40	
DINHF50HM50-90	SS 1.4404	25 bar	DN50	DN50	
DINHF65HM65-90	SS 1.4404	25 bar	DN65	DN65	
DINHF80HM80-90	SS 1.4404	25 bar	DN80	DN80	

Vaterteil DIN 11851 mit IBC Innengewinde - ohne Dichtung

Male DIN 11851 with IBC female thread - without gasket

Mâle DIN 11851 avec taraudage IBC femelle - sans joint

Macho DIN 11851 con rosca hembra IBC - sin junta

Wtyk Część Męska DIN 11851 / Złącze IBC z gwintem wewnętrznym - bez uszczelki

Accoppiamento maschio DIN 11851 con Accoppiamento filettatura femmina IBC- senza guarnizione



Part-No.	Material	WP	IBC	DINHM	Price
IBCF60DINHM25-SS	SS 1.4404	25 bar	S60x6	DN25	
IBCF60DINHM32-SS	SS 1.4404	25 bar	S60x6	DN32	
IBCF60DINHM40-SS	SS 1.4404	25 bar	S60x6	DN40	
IBCF60DINHM50-SS	SS 1.4404	25 bar	S60x6	DN50	





90° Bogen AG/AG BSPP flachdichtend

90° elbow male BSPP thread - flat sealing
 90° Coude mâle/mâle à joint plat
 Codo 90° RM-RM BSPP
 90° Lolanoz gwintami zewnętrznymi cylindrycznymi
 Curva 90° maschio - maschio BSPPP

Part-No.	Material	WP	Thread	Thread	Price
MMS075075FL-90	SS 316	16 bar	3/4"	3/4"	
MMS1010FL-90	SS 316	16 bar	1"	1"	
MMS1212FL-90	SS 316	16 bar	1 1/4"	1 1/4"	
MMS1515FL-90	SS 316	16 bar	1 1/2"	1 1/2"	
MMS2020FL-90	SS 316	16 bar	2"	2"	
MMS3030FL-90	SS 316	16 bar	3"	3"	
MMS4040FL-90	SS 316	16 bar	4"	4"	



Vaterteil DIN 11851 mit IBC Außengewinde

ohne Dichtung

Male DIN 11851 with IBC male thread - without gasket
 Mâle DIN 11851 avec filetage IBC mâle - sans jointt
 Macho DIN 11851 con rosca macho IBC - sin junta
 Wtyk Część Męska DIN 11851/ Złącze IBC z gwintem zewnętrznym - bez Uszczelka
 Maschio DIN con filettatura maschio IBC - senza guarnizione

Part-No.	Material	WP	IBC	DIN 11851	Price
IBCM60DINM25-SS	SS 1.4404	25 bar	S60x6	DN25	
IBCM60DINM32-SS	SS 1.4404	25 bar	S60x6	DN32	
IBCM60DINM40-SS	SS 1.4404	25 bar	S60x6	DN40	
IBCM60DINM50-SS	SS 1.4404	25 bar	S60x6	DN50	
IBCM60DINM65-SS	SS 1.4404	25 bar	S60x6	DN65	
IBCM60DINM80-SS	SS 1.4404	25 bar	S60x6	DN80	



Übergangsstück Kegelstutzen DIN 11851 mit Überwurfmutter (SS 1.4301)

auf CLAMP Kupplung DIN32676 - ohne Dichtung

Adapter DIN female with nut to Clamp coupling - DIN32676- without gasket

Adaptateur DIN femelle avec écrou - avec raccord micro-CLAMP - DIN32676 - sans joint

Hembra DIN 11851 con tuerca a racor clamp - DIN32676- sin junta

Adapter DIN 11851 - Część żeńska z nakrętką na końcówkę / Złącze «Clamp» - DIN32676 - bez Uszczelka

Accoppiamento femmina DIN con girella con accoppiamento Clamp - DIN32676 - senza guarnizione



Part-No.	Material	WP	DIN 11851	Clamp Disk	Price
DINHF20CLH076	SS 1.4404	25 bar	DN20	34	
DINHF25CLH106	SS 1.4404	25 bar	DN25	50,5	
DINHF32CLH125	SS 1.4404	25 bar	DN32	50,5	
DINHF40CLH156	SS 1.4404	25 bar	DN40	50,5	
DINHF50CLH206	SS 1.4404	25 bar	DN50	64	
DINHF65CLH256	SS 1.4404	25 bar	DN65	91	
DINHF80CLH306	SS 1.4404	25 bar	DN80	106	

Übergangsstück Außengewinde DIN 11851 auf CLAMP Kupplung DIN32676 (ohne Dichtung)

Adapter DIN male to Clamp coupling - DIN32676 - without gasket

Adaptateur DIN Mâle - avec raccord micro-CLAMP - DIN32676- sans joint

Macho DIN a racor Clamp - DIN32676- sin junta

Adapter DIN 11851 - Wtyk Część Męska DIN 11851 / Złącze «Clamp» - DIN32676 - bez Uszczelka

Accoppiamento maschio DIN con accoppiamento Clamp - DIN32676



Part-No.	Material	WP	DIN 11851	Clamp Disk	Price
DINHM20CLH076	SS 1.4404	25 bar	DN20	34	
DINHM25CLH106	SS 1.4404	25 bar	DN25	50,5	
DINHM32CLH125	SS 1.4404	25 bar	DN32	50,5	
DINHM40CLH156	SS 1.4404	25 bar	DN40	50,5	
DINHM50CLH206	SS 1.4404	25 bar	DN50	64	
DINHM65CLH256	SS 1.4404	25 bar	DN65	91	
DINHM80CLH306	SS 1.4404	25 bar	DN80	106	





Übergangsstück Außengewinde DIN 11851 auf Macon Kupplung

Adapter DIN male to Macon Male coupling
 Adaptateur DIN Mâle - avec Macon mâle
 Macho DIN 11851 a Macon
 Adapter DIN 11851 - Wtyk Część Męska DIN 11851 / Część Żeńska Macon
 Accoppiamento maschio DIN con accoppiamento Maschio Macon

Part-No.	Material	WP	DIN 11851	Macon	Price
DINHM40MACM38	SS 1.4404	25 bar	DN40	DN38	
DINHM50MACM50	SS 1.4404	25 bar	DN50	DN50	
DINHM80MACM70	SS 1.4404	25 bar	DN80	DN70	



DIN 11851 - Außengewinde auf SMS 1145 Außengewinde

DIN male to SMS 1145 male
 DIN Mâle avec SMS 1445 Mâle
 Macho DIN 11851 a macho SMS 1445
 DIN 11851 - Wtyk Część Męska / SMS 1445 - - Wtyk Część Męska
 Maschio DIN a Maschio SMS 1145

Part-No.	Material	WP	DIN 11851	SMS 1145	Price
DINHM25SMSHM25	SS 1.4404	25 bar	DN25	DN25	
DINHM32SMSHM32	SS 1.4404	25 bar	DN32	DN32	
DINHM40SMSHM38	SS 1.4404	25 bar	DN40	DN38	
DINHM50SMSHM50	SS 1.4404	25 bar	DN50	DN50	
DINHM65SMSHM63	SS 1.4404	25 bar	DN65	DN63	
DINHM80SMSHM76	SS 1.4404	25 bar	DN80	DN76	



DIN 11851 Überwurfmutter

DIN nut

Ecrou DIN

Tuerca DIN

Nakrętka DIN 11851

Girella DIN 11851



Part-No.	Material	WP	Dimension	Price
DINE15	SS 1.4301	25 bar	DN15	
DINE20	SS 1.4301	25 bar	DN20	
DINE25	SS 1.4301	25 bar	DN25	
DINE32	SS 1.4301	25 bar	DN32	
DINE40	SS 1.4301	25 bar	DN40	
DINE50	SS 1.4301	25 bar	DN50	
DINE65	SS 1.4301	25 bar	DN65	
DINE80	SS 1.4301	25 bar	DN80	
DINE100	SS 1.4301	25 bar	DN100	

NEW**Stopfen für Milchrohrverschraubung DIN 11851**

DIN Plug

Bouchon DIN

Tapón macho DIN 11851

Zaślepka DIN 11851

Tappo di chiusura DIN



Part-No.	Material	WP	Dimension	Price
DINP20	SS 1.4301	25 bar	DN20	
DINP25	SS 1.4301	25 bar	DN25	
DINP32	SS 1.4301	25 bar	DN32	
DINP40	SS 1.4301	25 bar	DN40	
DINP50	SS 1.4301	25 bar	DN50	
DINP65	SS 1.4301	25 bar	DN65	
DINP80	SS 1.4301	25 bar	DN80	
DINP100	SS 1.4301	25 bar	DN100	





Stopfen für Milchrohrverschraubung DIN 11851 - mit Griff

DIN plug with Handle
 Bouchon DIN avec poignée
 Tapón macho DIN 11851 con maneta
 Zaślepka DIN 11851 do MK z rączką
 Tappo maschio DIN con maniglia

Part-No.	Material	WP	Dimension	Price
DINP15-G	SS 1.4301	25 bar	DN15	
DINP20-G	SS 1.4301	25 bar	DN20	
DINP25-G	SS 1.4301	25 bar	DN25	
DINP32-G	SS 1.4301	25 bar	DN32	
DINP40-G	SS 1.4301	25 bar	DN40	
DINP50-G	SS 1.4301	25 bar	DN50	
DINP65-G	SS 1.4301	25 bar	DN65	
DINP80-G	SS 1.4301	25 bar	DN80	
DINP100-G	SS 1.4301	25 bar	DN100	



Kappe für Milchrohrverschraubung DIN 11851 mit Kette

DIN cap with chain
 Bouchon DIN avec chaîne
 Tapón ciego hembra DIN 11851
 Nakrętka zaślepiająca DIN 11851 z łańcuszkiem
 Tappo DIN con catena

Part-No.	Material	WP	Dimension	Price
DINC20	SS 1.4301	25 bar	DN20	
DINC25	SS 1.4301	25 bar	DN25	
DINC32	SS 1.4301	25 bar	DN32	
DINC40	SS 1.4301	25 bar	DN40	
DINC50	SS 1.4301	25 bar	DN50	
DINC65	SS 1.4301	25 bar	DN65	
DINC80	SS 1.4301	25 bar	DN80	
DINC100	SS 1.4301	25 bar	DN100	



Kappe für Milchrohrverschraubung DIN 11851 mit Kette

DIN female cap with handle

Bouchon DIN avec poignée

Tapón hembra DIN 11851 con maneta

Nakrętka zaślepiająca DIN 11851 z łańcuszkiem

Tappo femmina DIN con maniglia



Part-No.	Material	WP	Dimension	Price
DINC15-G	SS 1.4301	25 bar	DN15	
DINC20-G	SS 1.4301	25 bar	DN20	
DINC25-G	SS 1.4301	25 bar	DN25	
DINC32-G	SS 1.4301	25 bar	DN32	
DINC40-G	SS 1.4301	25 bar	DN40	
DINC50-G	SS 1.4301	25 bar	DN50	
DINC65-G	SS 1.4301	25 bar	DN65	
DINC80-G	SS 1.4301	25 bar	DN80	
DINC100-G	SS 1.4301	25 bar	DN100	

Blindkegel für Milchrohrverschraubung DIN 11851

DIN blank liner

Bouchon DIN

Tapón ciego DIN 11851

Zaślepka stożkowa DIN 11851

Tappo DIN 11851 corpo cono cieco



Part-No.	Material	WP	Dimension	Price
DINP15F	SS 1.4301	25 bar	DN15	
DINP20F	SS 1.4301	25 bar	DN20	
DINP25F	SS 1.4301	25 bar	DN25	
DINP32F	SS 1.4301	25 bar	DN32	
DINP40F	SS 1.4301	25 bar	DN40	
DINP50F	SS 1.4301	25 bar	DN50	



Gummi Prallschutz für Milchrohr DIN 11851 Überwurfmutter

Rubber protection for DIN nut

Protection d'écrou DIN

Protección de goma para tuerca DIN

Gumowa ochrona przed uderzeniami dla DIN Nakrętki

Protezione in gomma per girella DIN



Part-No.	Colour	Material	Shore°	Dimension	Price
DINE25B	Blue	EPDM	60	DN25	
DINE32B	Blue	EPDM	60	DN32	
DINE40B	Blue	EPDM	60	DN40	
DINE50B	Blue	EPDM	60	DN50	
DINE65B	Blue	EPDM	60	DN65	
DINE80B	Blue	EPDM	60	DN80	
DINE100B	Blue	EPDM	60	DN100	
DINE25R	Red	EPDM	60	DN25	
DINE32R	Red	EPDM	60	DN32	
DINE40R	Red	EPDM	60	DN40	
DINE50R	Red	EPDM	60	DN50	
DINE65R	Red	EPDM	60	DN65	
DINE80R	Red	EPDM	60	DN80	
DINE100R	Red	EPDM	60	DN100	
DINE25S	Black	EPDM	60	DN25	
DINE32S	Black	EPDM	60	DN32	
DINE40S	Black	EPDM	60	DN40	
DINE50S	Black	EPDM	60	DN50	
DINE65S	Black	EPDM	60	DN65	
DINE80S	Black	EPDM	60	DN80	
DINE100S	Black	EPDM	60	DN100	



Gummi Prallschutz für DIN Überwurfmutter

Rubber protection for DIN nut

Protection d'écrou DIN

Protección de goma para tuerca DIN

Gumowa ochrona przed uderzeniami dla DIN Nakrętki

Protezione in gomma per girella DIN

Part-No.	Colour	Material	Shore°	Dimension	Price
DINE25W	White	EPDM	60	DN25	
DINE32W	White	EPDM	60	DN32	
DINE40W	White	EPDM	60	DN40	
DINE50W	White	EPDM	60	DN50	
DINE65W	White	EPDM	60	DN65	
DINE80W	White	EPDM	60	DN80	
DINE100W	White	EPDM	60	DN100	



Prallschutz - Formteil

Protection ring

Anneau de protection

Anillo de protección

Ochrona przed uderzeniami

Anello di protezione



Part-No.	Colour	Material	Shore°	DN	ID ø	OD ø	Price
RDP025B	Blue	NR	45	DN25	35mm	95mm	
RDP025B-37	Blue	NR	45	DN25	37mm	95mm	
RDP032B	Blue	NR	45	DN32	44mm	103mm	
RDP038B	Blue	NR	45	DN38	45mm	105mm	
RDP040B	Blue	NR	45	DN40	51mm	105mm	
RDP040B-54	Blue	NR	45	DN40	54mm	115mm	
RDP040B-58	Blue	NR	45	DN40	58mm	115mm	
RDP050B	Blue	NR	45	DN50	60mm	115mm	
RDP050B-66	Blue	NR	45	DN50	66mm	115mm	
RDP065B	Blue	NR	45	DN65	70mm	130mm	
RDP065B-89	Blue	NR	45	DN65	89mm	130mm	
RDP070B	Blue	NR	45	DN70	78mm	145mm	
RDP075B	Blue	NR	45	DN75	85mm	145mm	
RDP025R	Red	NR	45	DN25	35mm	95mm	
RDP025R-37	Red	NR	45	DN25	37mm	95mm	
RDP032R	Red	NR	45	DN32	44mm	103mm	
RDP038R	Red	NR	45	DN38	45mm	105mm	
RDP040R	Red	NR	45	DN40	51mm	105mm	
RDP040R-54	Red	NR	45	DN40	54mm	115mm	
RDP040R-58	Red	NR	45	DN40	58mm	115mm	
RDP050R	Red	NR	45	DN50	60mm	115mm	
RDP050R-66	Red	NR	45	DN50	66mm	115mm	
RDP065R	Red	NR	45	DN65	70mm	130mm	
RDP065R-89	Red	NR	45	DN65	89mm	130mm	
RDP070R	Red	NR	45	DN70	78mm	145mm	
RDP075R	Red	NR	45	DN75	85mm	145mm	

LEBENSMITTELINDUSTRIE



Prallschutz - Formteil

Protection ring

Anneau de protection

Anillo de protección

Ochrona przed uderzeniami

Anello di protezione

Part-No.	Colour	Material	Shore°	DN	ID ϕ	OD ϕ	Price
RDP025S	Black	NR	45	DN25	35mm	95mm	
RDP025S-37	Black	NR	45	DN25	37mm	95mm	
RDP032S	Black	NR	45	DN32	44mm	103mm	
RDP038S	Black	NR	45	DN38	45mm	105mm	
RDP040S	Black	NR	45	DN40	51mm	105mm	
RDP040S-54	Black	NR	45	DN40	54mm	115mm	
RDP040S-58	Black	NR	45	DN40	58mm	115mm	
RDP050S	Black	NR	45	DN50	60mm	115mm	
RDP050S-66	Black	NR	45	DN50	66mm	115mm	
RDP065S	Black	NR	45	DN65	70mm	130mm	
RDP065S-89	Black	NR	45	DN65	89mm	130mm	
RDP070S	Black	NR	45	DN70	78mm	145mm	
RDP075S	Black	NR	45	DN75	85mm	145mm	
RDP025W	White	NR	45	DN25	35mm	95mm	
RDP025W-37	White	NR	45	DN25	37mm	95mm	
RDP032W	White	NR	45	DN32	44mm	103mm	
RDP038W	White	NR	45	DN38	45mm	105mm	
RDP040W	White	NR	45	DN40	51mm	105mm	
RDP040W-54	White	NR	45	DN40	54mm	115mm	
RDP040W-58	White	NR	45	DN40	58mm	115mm	
RDP050W	White	NR	45	DN50	60mm	115mm	
RDP050W-66	White	NR	45	DN50	66mm	115mm	
RDP065W	White	NR	45	DN65	70mm	130mm	
RDP065W-89	White	NR	45	DN65	89mm	130mm	
RDP070W	White	NR	45	DN70	78mm	145mm	
RDP075W	White	NR	45	DN75	85mm	145mm	



INFORMATIONEN

SMS Kupplungen 1145

Der Schwedische Fertigungsstandard (SMS) ist eine Milchrohrverschraubung mit DIN 405-1 Gewinde, die jedoch nicht mit dem DIN 11851 Standard verwechselt werden darf.

Bei der SMS-Armatur kommt ein O-Ring zum Dichten zum Einsatz. Ein charakteristisches Merkmal der SMS-Armatur ist

die stark angefasste Überwurfmutter. Schlauchseitig erfolgt die Konfektion mit Überwurfmutter und Stutzen, während rohrrseitig ein Außengewinde und eine O-Ring-Nut verwendet werden.

MCC bietet zudem Gewindestützen mit Anschweißende an, die sich auch für den Einsatz in Orbitalschweißanlagen

eignen.

Die SMS-Armatur ist flachdichtend und kann nicht mit einer herkömmlichen Milchrohrverschraubung dichtend verbunden werden.



WARUM MCC?

- Die Armatur wird mit hochwertigen Werkstoffen und bester Oberflächenqualität hergestellt
- Die Gewinde sind lehrdorngeprüft
- Chargen sind mit einem 3.1 Zeugnis dokumentiert
- MCC verfügt über Adaptermöglichkeiten wie auf TriCLamp, S60x6 Faßgewinde, Milchrohrverschraubung (DIN 11851)
- passende Prallschutzsysteme in unterschiedlichen Farben

TECHNISCHE INFORMATIONEN

- Norm: DIN 405-1 sowie SMS 1145
- Schlauchanschlüsse: DIN EN 14420
- Prallringe in NR, Prallschutz in EPDM
- H3 Oberfläche, Ra von 0,8µm
- Chargennachweis
- Werkstoffe:
 - 1.4404 - Nutmutter 1.4301
- H3 Hygieneklasse

EINSATZGEBIET

Nahezu universelle Verschraubung in Chemie- und Lebensmittel-industrie.

Sie ist überwiegend in Nordeuropa zu finden und kann zur Vermeidung von Verwechslungen ergänzend zur Milchrohrverschraubung eingesetzt werden.

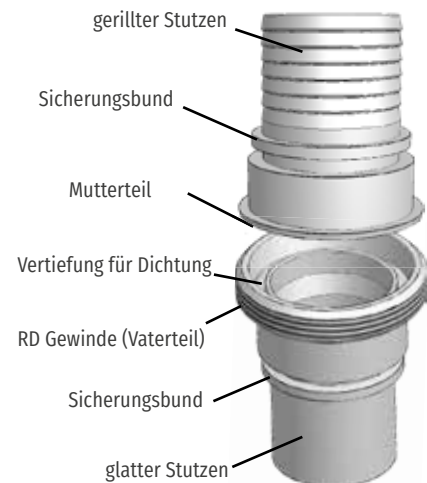

INFORMATION

SMS Couplings 1145



The Swedish Manufacturing Standard (SMS) is a milk pipe fitting with a DIN 405-1 thread, which should not be confused with the DIN 11851 standard.

An O-ring is used to seal the SMS fitting. A characteristic feature of the SMS fitting is the strongly gripped Nut.

On the hose side, the fitting is assembled

with a nut and hose shank, while an external thread and an O-ring are used on the pipe side.

MCC also offers male thread with welding ends, which are also suitable for use in orbital welding systems.

The SMS fitting is flat-sealing and cannot be connected with a conventional milk

pipe fitting.

WHY MCC?

- The fitting is manufactured with high-quality materials and the best surface quality
- The threads are gauge tested
- Batches are documented with a 3.1 certificate
- MCC has adapter options such as on TriClamp, S60x6 thread, DIN 11851
- Matching rubber protection systems in different colors



TECHNICAL INFORMATION

- Norm: DIN 405-1 and SMS 1145
- Hose connection: DIN EN 14420
- Protection ring NR, Rubber protection EPDM
- H3 surface, Ra of 0.8µm
- Heat-Numbers
- Materials:
1.4404 - Nut 1.4301
- H3 Hygiene class

AREA OF APPLICATION

Almost universal fitting in chemical and food processing plants. The nut and conical connector are assembled with the hose line.

The nut should protect the cone. The external thread with seal is welded to the pipe, so MCC external threads with weld-on ends are available.

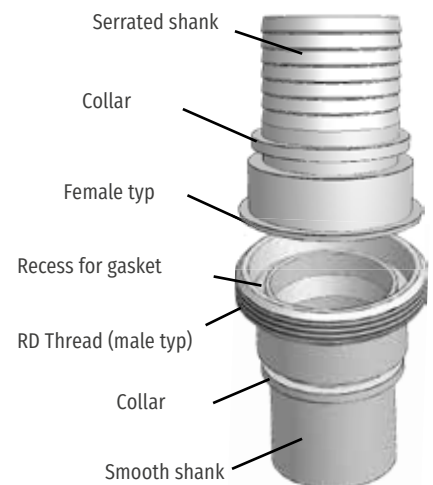



SMS 1145 Mutterteil - Kupplung mit Rillenstutzen und Sicherungsbund
(ohne Überwurfmutter)

Female SMS serrated shank with collar (without nut)

Femelle SMS douille annelée à collerette

Hembra SMS con espiga dentada y cuello de seguridad

Część żeńska SMS - z karbowaną końcówką do węża z wiązka zabezpieczającą (bez nakrętki)

Raccordo femmina SMS portagomma con collare di sicurezza

Part-No.	Material	WP	Dimension	Shank	Price
SMSHF25	SS 1.4404	25 bar	DN25	25mm	
SMSHF32	SS 1.4404	25 bar	DN32	32mm	
SMSHF38	SS 1.4404	25 bar	DN38	38mm	
SMSHF50	SS 1.4404	25 bar	DN51	51mm	
SMSHF63	SS 1.4404	25 bar	DN63	63mm	
SMSHF76	SS 1.4404	25 bar	DN76	76mm	
SMSHF100	SS 1.4404	25 bar	DN104	101mm	



SMS 1145 Mutterteil - Kupplung mit glattem Stutzen und Sicherungsbund
(ohne Überwurfmutter)

Female SMS smooth shank with collar (without nut)

Femelle SMS douille lisse à collerette

Hembra SMS con espiga lisa y cuello de seguridad

Część żeńska SMS - z gładką końcówką do węża z wiązka zabezpieczającą (bez nakrętki)

Raccordo femmina SMS portagomma liscio con collare di sicurezza

Part-No.	Material	WP	Dimension	Shank	Price
SMSHF25SM	SS 1.4404	25 bar	DN25	25mm	
SMSHF32SM	SS 1.4404	25 bar	DN32	32mm	
SMSHF38SM	SS 1.4404	25 bar	DN38	38mm	
SMSHF50SM	SS 1.4404	25 bar	DN51	51mm	
SMSHF63SM	SS 1.4404	25 bar	DN63	63mm	
SMSHF76SM	SS 1.4404	25 bar	DN76	76mm	
SMSHF100SM	SS 1.4404	25 bar	DN104	100mm	



SMS 1145 Vaterteil - Kupplung mit Rillenstutzen und Sicherungsbund

(ohne Dichtung)

Male SMS serrated shank with collar (without gasket)

Mâle SMS douille annelée à collerette

Macho SMS con espiga dentada y cuello de seguridad

Część Męska z gwintem zewnętrznym SMS z karbowaną końcówką do węża z wiązką zabezpieczającą (bez uszczelki)

Raccordo maschio SMS portagomma con collare di sicurezza



Part-No.	Material	WP	Dimension	Shank	Price
SMSHM25	SS 1.4404	25 bar	DN25	25mm	
SMSHM32	SS 1.4404	25 bar	DN32	32mm	
SMSHM38	SS 1.4404	25 bar	DN38	38mm	
SMSHM50	SS 1.4404	25 bar	DN50	51mm	
SMSHM63	SS 1.4404	25 bar	DN63	63mm	
SMSHM76	SS 1.4404	25 bar	DN76	76mm	
SMSHM100	SS 1.4404	25 bar	DN104	101mm	

SMS 1145 Vaterteil - Kupplung mit glattem Stutzen und Sicherungsbund

(ohne Dichtung)

Male SMS smooth shank with collar (without gasket)

Mâle SMS douille lisse à collerette

Macho SMS con espiga lisa y cuello de seguridad

Część Męska z gwintem zewnętrznym SMS z gładką końcówką do węża z wiązką zabezpieczającą (bez uszczelki)

Raccordo maschio SMS portagomma liscio con collare di sicurezza



Part-No.	Material	WP	Dimension	Shank	Price
SMSHM25SM	SS 1.4404	25 bar	DN25	25mm	
SMSHM32SM	SS 1.4404	25 bar	DN32	32mm	
SMSHM38SM	SS 1.4404	25 bar	DN38	38mm	
SMSHM50SM	SS 1.4404	25 bar	DN50	51mm	
SMSHM63SM	SS 1.4404	25 bar	DN63	63mm	
SMSHM76SM	SS 1.4404	25 bar	DN76	76mm	
SMSHM100SM	SS 1.4404	25 bar	DN104	101mm	





90° Bogen AG/AG BSPP flachdichtend

90° Elbow male BSPP thread - flat sealing
 90° Coude mâle/mâle à joint plat
 Codo 90° RM-RM BSPP
 90° Lolanoz gwintami zewnętrznymi cylindrycznymi
 Curva 90° maschio - maschio BSPPP

Part-No.	Material	WP	Thread	Thread	Price
MMS075075FL-90	SS 316	16 bar	3/4"	3/4"	
MMS1010FL-90	SS 316	16 bar	1"	1"	
MMS1212FL-90	SS 316	16 bar	1 1/4"	1 1/4"	
MMS1515FL-90	SS 316	16 bar	1 1/2"	1 1/2"	
MMS2020FL-90	SS 316	16 bar	2"	2"	
MMS3030FL-90	SS 316	16 bar	3"	3"	
MMS4040FL-90	SS 316	16 bar	4"	4"	



SMS 1145 Vaterteil auf BSPP Außengewinde

Male SMS to BSPP male thread
 Mâle SMS - Filetage mâle BSPP
 Macho SMS - Macho BSPP
 Część Męska z gwintem zewnętrznym na końcówkę z gwintem Męska BSPP
 Adattatore Maschio SMS - filetto maschio BSPP

Part-No.	Material	WP	SMS	Thread	Price
SMSHM25AG	SS 1.4404	25 bar	DN25	1"	
SMSHM32AG	SS 1.4404	25 bar	DN32	1 1/4"	
SMSHM38AG	SS 1.4404	25 bar	DN38	1 1/2"	
SMSHM50AG	SS 1.4404	25 bar	DN50	2"	
SMSHM63AG	SS 1.4404	25 bar	DN63	2 1/2"	
SMSHM76AG	SS 1.4404	25 bar	DN76	3"	



SMS 1145 Mutterteil auf BSPP Außengewinde

Female SMS to BSPP male thread

Femelle SMS - Filetage mâle BSPP

Hembra SMS - Macho BSPP

Nakrętka SMS - na gwint zewnętrzny BSPP

Adattatore femmina SMS - filettato maschio BSPP



Part-No.	Material	WP	SMS	Thread	Price
SMSHF25AG	SS 1.4404	25 bar	DN25	1"	
SMSHF32AG	SS 1.4404	25 bar	DN32	1 1/4"	
SMSHF38AG	SS 1.4404	25 bar	DN38	1 1/2"	
SMSHF50AG	SS 1.4404	25 bar	DN51	2"	
SMSHF63AG	SS 1.4404	25 bar	DN63	2 1/2"	
SMSHF76AG	SS 1.4404	25 bar	DN76	3"	

SMS 1145 - Vaterteil auf Vaterteil

SMS Male to SMS Male

SMS - Mâle - Mâle

Macho SMS - Macho SMS

SMS- obie strony Część Męska z gwintem zewnętrznym

Adattatore maschio SMS - maschio SMS



Part-No.	Material	WP	SMS	SMS	Price
SMSHM25HM25	SS 1.4404	25 bar	DN25	DN25	
SMSHM32HM32	SS 1.4404	25 bar	DN32	DN32	
SMSHM38HM38	SS 1.4404	25 bar	DN38	DN38	
SMSHM50HM50	SS 1.4404	25 bar	DN50	DN50	
SMSHM63HM63	SS 1.4404	25 bar	DN63	DN63	
SMSHM76HM76	SS 1.4404	25 bar	DN76	DN76	





SMS 1145 Vaterteil mit IBC Innengewinde

SMS 1145 male thread with IBC female thread
 Filetage mâle SMS 1145 avec taraudage femelle IBC
 Rosca macho SMS 1145 con Rosca hembra IBC
 gwintem zewnętrznym SMS 1145 z Gwint wewnętrzny IBC
 Filettato maschio SMS 1145 con Filettato femmina IBCa

Part-No.	Material	WP	IBC	SMS	Price
IBCF60SMSHM25-SS	SS 1.4404	25 bar	S60x6	DN25	
IBCF60SMSHM32-SS	SS 1.4404	25 bar	S60x6	DN32	
IBCF60SMSHM38-SS	SS 1.4404	25 bar	S60x6	DN38	
IBCF60SMSHM50-SS	SS 1.4404	25 bar	S60x6	DN50	



SMS 1145 Vaterteil mit IBC Außengewinde

SMS 1145 male thread with IBC male thread
 Filetage mâle SMS 1145 avec filetage mâle IBC
 Rosca macho SMS 1145 con Rosca macho IBC
 Gwintem zewnętrznym SMS 1145 z Gwint zewnętrzny IBC
 Filettato maschio SMS 1145 con Filettato maschio IBC

Part-No.	Material	WP	IBC	SMS	Price
IBCM60SMSHM25-SS	SS 1.4404	25 bar	S60x6	DN25	
IBCM60SMSHM32-SS	SS 1.4404	25 bar	S60x6	DN32	
IBCM60SMSHM38-SS	SS 1.4404	25 bar	S60x6	DN38	
IBCM60SMSHM50-SS	SS 1.4404	25 bar	S60x6	DN50	



SMS 1145 Vaterteil auf DIN 11851 Vaterteil

SMS 1145 male to DIN male

SMS 1145 mâle avec DIN mâle

Macho SMS 1145 a Macho DIN 11851

SMS 1145 - Wtyk Część Męska / DIN 11851 - Wtyk Część Męska

Maschio SMS 1145 - Maschio DIN 11851



Part-No.	Material	WP	DIN	SMS	Price
DINHM25SMSHM25	SS 1.4404	25 bar	DN25	DN25	
DINHM32SMSHM32	SS 1.4404	25 bar	DN32	DN32	
DINHM40SMSHM38	SS 1.4404	25 bar	DN40	DN38	
DINHM50SMSHM50	SS 1.4404	25 bar	DN50	DN50	
DINHM65SMSHM63	SS 1.4404	25 bar	DN65	DN63	
DINHM80SMSHM76	SS 1.4404	25 bar	DN80	DN76	

SMS 1145 Vaterteil auf CLAMP 32676 Kupplung

Male SMS 1145 to Clamp coupling

Mâle SMS 1145 avec raccord micro-CLAMP

Macho SMS 1145 con Clamp 32676

Część Męska 1145 / Złącze «Clamp»

Maschio SMS 1145 - Clamp 32676



Part-No.	Material	WP	SMS	Disk	Price
SMSHM25CLH106	SS 1.4404	25 bar	DN25	50.5	
SMSHM32CLH125	SS 1.4404	25 bar	DN32	50.5	
SMSHM38CLH156	SS 1.4404	25 bar	DN38	50.5	
SMSHM50CLH206	SS 1.4404	25 bar	DN50	64	
SMSHM63CLH256	SS 1.4404	25 bar	DN63	91	
SMSHM76CLH306	SS 1.4404	25 bar	DN76	106	





SMS 1145 Überwurfmutter

SMS Nut
 Ecrou SMS
 Tuerca SMS
 Nakrętka SMS
 Girella SMS

Part-No.	Material	WP	Dimension	Price
SMSE025	SS 1.4301	25 bar	DN25	
SMSE032	SS 1.4301	25 bar	DN32	
SMSE038	SS 1.4301	25 bar	DN38	
SMSE050	SS 1.4301	25 bar	DN50	
SMSE063	SS 1.4301	25 bar	DN63	
SMSE075	SS 1.4301	25 bar	DN76	
SMSE100	SS 1.4301	25 bar	DN104	



SMS 1145 Mutterteil mit Anschweißende (ohne Überwurfmutter) (kurze Ausführung)

Female SMS welding (without nut) (short version)
 Femelle SMS à souder (version courte)
 Hembra SMS para soldar (versión corta)
 Część żeńska SMS z krótcem do spawania (bez nakrętki) (wersja skrócona)
 Femmina SMS a saldare (versione corta)

Part-No.	Material	WP	Dimension	BW (IDxOD)	Price
SMSASF25	SS 1.4404	25 bar	DN25	22,6x25	
SMSASF38	SS 1.4404	25 bar	DN38	35,6x38	
SMSASF50	SS 1.4404	25 bar	DN50	48,6x51	
SMSASF63	SS 1.4404	25 bar	DN63	60,3x63,5	
SMSASF75	SS 1.4404	25 bar	DN76	72,9x76	
SMSASF104	SS 1.4404	25 bar	DN104	99,6x104,2	



SMS 1145 Vaterteil mit Anschweißende (ohne Dichtung)

(kurze Ausführung)

Male SMS welding (without gasket) (short version)

Mâle SMS à souder (version courte)

Macho SMS para soldar (versión corta)

Część Męska z gwintem zewnętrznym SMS z króćcem do spawania (bez uszczelki) (wersja skrócona)

Maschio SMS a saldare (versione corta)



Part-No.	Material	WP	Dimension	BW (IDxOD)	Price
SMSASM25	SS 1.4404	25 bar	DN25	22,6x25,0	
SMSASM38	SS 1.4404	25 bar	DN38	35,6x38,0	
SMSASM50	SS 1.4404	25 bar	DN50	48,6x51	
SMSASM63	SS 1.4404	25 bar	DN63	60,3x63,5	
SMSASM75	SS 1.4404	25 bar	DN76	72,9x76,0	
SMSASM104	SS 1.4404	25 bar	DN104	99,6x104,2	

SMS Montage-Schlüssel

SMS Spanner

Clé SMS

Llave plana SMS

SMS Klucz do montażu

Chiave piana per SMS



Part-No.	Material	Dimension 1	Dimension 2	Price
SGE	Stainless Steel	DN50	DN100	63,24 €



Gummi Prallschutz für SMS Überwurfmutter

Rubber protection for SMS Nut

Protection d'écrou SMS

Protección para tuerca SMS

Gumowa ochrona przed uderzeniami dla SMS Nakrętki

Protezione per girella SMS



Part-No.	Colour	Material	Shore°	DN	Price
SMSE025B	Blue	EPDM	60	DN25	
SMSE032B	Blue	EPDM	60	DN32	
SMSE038B	Blue	EPDM	60	DN40	
SMSE050B	Blue	EPDM	60	DN50	
SMSE063B	Blue	EPDM	60	DN65	
SMSE075B	Blue	EPDM	60	DN80	
SMSE025R	Red	EPDM	60	DN25	
SMSE032R	Red	EPDM	60	DN32	
SMSE038R	Red	EPDM	60	DN40	
SMSE050R	Red	EPDM	60	DN50	
SMSE063R	Red	EPDM	60	DN65	
SMSE075R	Red	EPDM	60	DN80	
SMSE025S	Black	EPDM	60	DN25	
SMSE032S	Black	EPDM	60	DN32	
SMSE038S	Black	EPDM	60	DN40	
SMSE050S	Black	EPDM	60	DN50	
SMSE063S	Black	EPDM	60	DN65	
SMSE075S	Black	EPDM	60	DN80	
SMSE025W	White	EPDM	60	DN25	
SMSE032W	White	EPDM	60	DN32	
SMSE038W	White	EPDM	60	DN40	
SMSE050W	White	EPDM	60	DN50	
SMSE063W	White	EPDM	60	DN65	
SMSE075W	White	EPDM	60	DN80	

LEBENSMITTELINDUSTRIE



Prallschutz

Protection ring

Anneau de protection

Anillo de protección

Ochrona przed uderzeniami

Anello di protezione

Part-No.	Colour	Material	Shore°	DN	ID ϕ	OD ϕ	Price
RDP025B	Blue	NR	45	DN25	35mm	95mm	
RDP025B-37	Blue	NR	45	DN25	37mm	95mm	
RDP032B	Blue	NR	45	DN32	44mm	103mm	
RDP038B	Blue	NR	45	DN38	45mm	105mm	
RDP040B	Blue	NR	45	DN40	51mm	105mm	
RDP040B-54	Blue	NR	45	DN40	54mm	115mm	
RDP040B-58	Blue	NR	45	DN40	58mm	115mm	
RDP050B	Blue	NR	45	DN50	60mm	115mm	
RDP050B-66	Blue	NR	45	DN50	66mm	115mm	
RDP065B	Blue	NR	45	DN65	70mm	130mm	
RDP065B-89	Blue	NR	45	DN65	89mm	130mm	
RDP070B	Blue	NR	45	DN70	78mm	145mm	
RDP075B	Blue	NR	45	DN75	85mm	145mm	
RDP025R	Red	NR	45	DN25	35mm	95mm	
RDP025R-37	Red	NR	45	DN25	37mm	95mm	
RDP032R	Red	NR	45	DN32	44mm	103mm	
RDP038R	Red	NR	45	DN38	45mm	105mm	
RDP040R	Red	NR	45	DN40	51mm	105mm	
RDP040R-54	Red	NR	45	DN40	54mm	115mm	
RDP040R-58	Red	NR	45	DN40	58mm	115mm	
RDP050R	Red	NR	45	DN50	60mm	115mm	
RDP050R-66	Red	NR	45	DN50	66mm	115mm	
RDP065R	Red	NR	45	DN65	70mm	130mm	
RDP065R-89	Red	NR	45	DN65	89mm	130mm	
RDP070R	Red	NR	45	DN70	78mm	145mm	
RDP075R	Red	NR	45	DN75	85mm	145mm	



Prallschutz

Protection ring
 Anneau de protection
 Anillo de protección
 Ochrona przed uderzeniami
 Anello di protezione



Part-No.	Colour	Material	Shore°	DN	ID ø	OD ø	Price
RDP025S	Black	NR	45	DN25	35mm	95mm	
RDP025S-37	Black	NR	45	DN25	37mm	95mm	
RDP032S	Black	NR	45	DN32	44mm	103mm	
RDP038S	Black	NR	45	DN38	45mm	105mm	
RDP040S	Black	NR	45	DN40	51mm	105mm	
RDP040S-54	Black	NR	45	DN40	54mm	115mm	
RDP040S-58	Black	NR	45	DN40	58mm	115mm	
RDP050S	Black	NR	45	DN50	60mm	115mm	
RDP050S-66	Black	NR	45	DN50	66mm	115mm	
RDP065S	Black	NR	45	DN65	70mm	130mm	
RDP065S-89	Black	NR	45	DN65	89mm	130mm	
RDP070S	Black	NR	45	DN70	78mm	145mm	
RDP075S	Black	NR	45	DN75	85mm	145mm	
RDP025W	White	NR	45	DN25	35mm	95mm	
RDP025W-37	White	NR	45	DN25	37mm	95mm	
RDP032W	White	NR	45	DN32	44mm	103mm	
RDP038W	White	NR	45	DN38	45mm	105mm	
RDP040W	White	NR	45	DN40	51mm	105mm	
RDP040W-54	White	NR	45	DN40	54mm	115mm	
RDP040W-58	White	NR	45	DN40	58mm	115mm	
RDP050W	White	NR	45	DN50	60mm	115mm	
RDP050W-66	White	NR	45	DN50	66mm	115mm	
RDP065W	White	NR	45	DN65	70mm	130mm	
RDP065W-89	White	NR	45	DN65	89mm	130mm	
RDP070W	White	NR	45	DN70	78mm	145mm	
RDP075W	White	NR	45	DN75	85mm	145mm	

LEBENSMITTELINDUSTRIE



INFORMATIONEN

Macon Kupplungen



Die ursprünglich französische Macon ist eine Milchrohrverschraubung mit DIN 405-1 Gewinde, die aber nicht mit dem DIN 11851 Standard verwechselt werden darf.

Bei der Macon wird ein rechteckiger Ring zum Dichten eingelegt. Das Außengewinde hat einen Rücksprung und der

Überwurfmutterstutzen einen Rücksprung. Ähnlich einer Clampverbindung kann die Verbindung nahezu spaltarm gekuppelt werden. Schlauchseitig erfolgt die Konfektion mit Überwurfmutter und Stutzen, rohrseitig mit Außengewinde und O-Ring Nut.

Somit hat MCC auch Gewindestutzen

mit Anschweißende auch für Orbitalschweißanlagen.

Die Macon ist flachdichtend und lässt sich nicht mit einer Milchrohrverschraubung oder anderen Lebensmittelarmaturen wie SMS kuppeln.



WARUM MCC?

- Die Armatur wird mit hochwertigen Werkstoffen und bester Oberflächenqualität hergestellt
- Chargen sind mit einem 3.1 Zeugnis dokumentiert
- MCC verfügt über Adaptermöglichkeiten wie auf TriCLamp, S60x6 Faßgewinde, Milchrohrverschraubung (DIN 11851)
- passende Prallschutzsysteme in unterschiedlichen Farben

TECHNISCHE INFORMATIONEN

- Norm: DIN 405-1
- Schlauchanschlüsse: DIN EN 14420
- Prallringe in NR, Prallschutz in EPDM
- Oberfläche, Ra von 0,8µm
- Chargennachweis
- Werkstoffe:
1.4404 - Nutmutter 1.4301
PFA ausgekleidet erhältlich

EINSATZGEBIET

Dieser Verschraubungstyp wird überwiegend in Frankreich in der Wein- und Getränkeindustrie eingesetzt

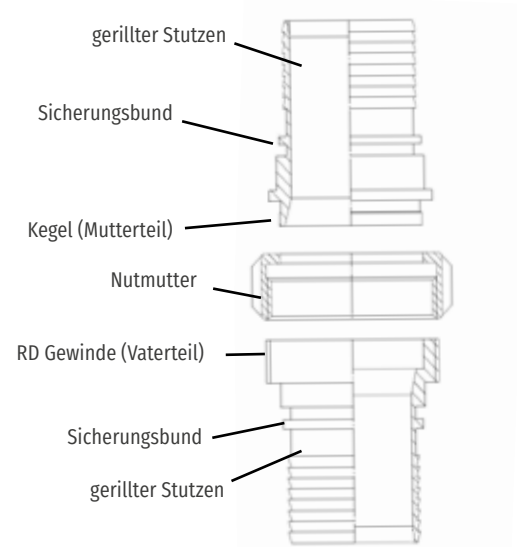



INFORMATION

Macon Couplings

The French Macon couplings is a coupling for the wine and Degestive production with a DIN 405-1 thread. It should not be confused with the DIN 11851 standard.

In this coupling system, a rectangular ring is inserted for sealing. The male threaded part has a recess and the nut socket has a recess. Similar to a clamp

connection, the connection can be coupled with virtually no gap. On the hose side, the connection is made with a nut and connecting paiece, on the pipe side with an external thread and O-ring groove.

This means that MCC also has hose shank with weld-on ends for orbital welding

systems.

The Macon is flat-sealing and cannot be connected with other food couplings like DIN or SMS.

WHY MCC?

- The fitting is manufactured using high-quality materials and the best surface quality
- Batches are documented with a 3.1 certificate
- MCC has adapter options such as on TriCLamp, S60x6 barrel thread, milk pipe screw connection (DIN 11851)
- Matching impact protection systems in different colors



TECHNICAL INFORMATION

- Norm: DIN 405-1
- Hose connection: DIN EN 14420
- Protection ring NR, Rubber protection EPDM
- surface, Ra of 0.8µm
- Heat-Numbers
- Materials:
1.4404 - Nut 1.4301
available with PFA lining

AREA OF APPLICATION

Mainly used in the French wine and beverage industry.

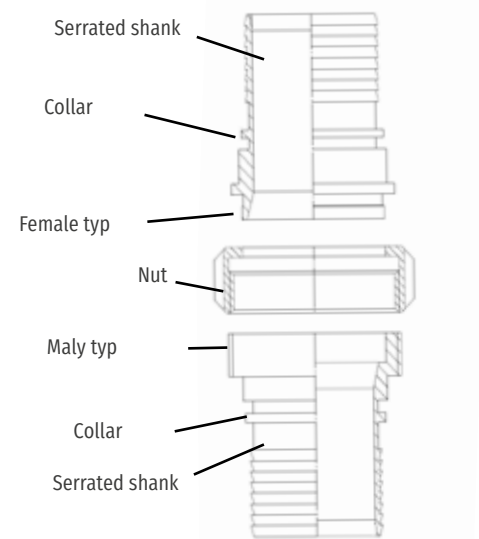



Macon Mutterteil - Kupplung mit Rillenstutzen und Sicherungsbund (ohne Überwurfmutter)

Female Macon with serrated shank with collar (without nut)

Femelle Macon douille annelée à collerette

Hembra Macon con espiga dentada y cuello de seguridad

Część Żeńska Macon - z karbowaną końcówką do węża z wiązką zabezpieczającą (bez nakrętki)

Raccordo femmina Macon portagomma con collare di sicurezza

Part-No.	Material	WP	Dimension	Shank	Price
MACF038	SS 1.4404	25 bar	DN38	38mm	
MACF050	SS 1.4404	25 bar	DN50	50mm	
MACF070	SS 1.4404	25 bar	DN70	70mm	



Macon Vaterteil - Kupplung mit Rillenstutzen und Sicherungsbund (ohne Dichtung)

Male Macon serrated shank with collar (without gasket)

Mâle Macon douille annelée à collerette

Macho Macon con espiga dentada y cuello de seguridad

Część Męska z gwintem zewnętrznym Macon z karbowaną końcówką do węża z wiązką zabezpieczającą (bez uszczelki)

Raccordo maschio Macon portagomma con collare di sicurezza

Part-No.	Material	WP	Dimension	Shank	Price
MACM038	SS 1.4404	25 bar	DN38	38mm	
MACM050	SS 1.4404	25 bar	DN50	50mm	
MACM070	SS 1.4404	25 bar	DN70	70mm	



Macon Mutterteil - Kupplung mit Rillenstutzen und Sicherungsbund

(ohne Überwurfmutter) - PFA ausgekleidet

Female Macon serrated shank with collar (without nut) - PFA coated

Femelle Macon douille annelée à collerette - Revêtu de PFA

Hembra Macon con espiga dentada y cuello de seguridad - Recubierto de PFA

Część Żeńska Macon - z karbowaną końcówką do węża z wiązką zabezpieczającą (bez nakrętki) - Z powłoką PFA

Raccordo femmina Macon portagomma con collare di sicurezza - Rivestimento in PFA

NEW

Part-No.	Material	WP	Coupling	Shank	Price
MACF038PFA-W	SS 1.4404 PFA white coated	16 bar	DN38	39mm	
MACF050PFA-W	SS 1.4404 PFA white coated	16 bar	DN50	50mm	
MACF070PFA-W	SS 1.4404 PFA white coated	16 bar	DN70	70mm	
MACF038PFA-B	SS 1.4404 PFA black coated	16 bar	DN38	39mm	
MACF050PFA-B	SS 1.4404 PFA black coated	16 bar	DN50	50mm	
MACF070PFA-B	SS 1.4404 PFA black coated	16 bar	DN70	70mm	



CONDUCTIVE

Macon Vaterteil - Kupplung mit Rillenstutzen und Sicherungsbund

(ohne Dichtung) - PFA ausgekleidet

Male Macon serrated shank with collar (without gasket) - PFA coated

Mâle Macon douille annelée à collerette - Revêtu de PFA

Macho Macon con espiga dentada y cuello de seguridad - Recubierto de PFA

Część Męska z gwintem zewnętrznym Macon z karbowaną końcówką do węża z wiązką zabezpieczającą (bez uszczelki)

Raccordo maschio Macon portagomma con collare di sicurezza - Rivestimento in PFA

NEW

Part-No.	Material	WP	Coupling	Shank	Price
MACM038PFA-W	SS 1.4404 PFA white coated	16 bar	DN38	39mm	
MACM050PFA-W	SS 1.4404 PFA white coated	16 bar	DN50	50mm	
MACM070PFA-W	SS 1.4404 PFA white coated	16 bar	DN70	70mm	
MACM038PFA-B	SS 1.4404 PFA black coated	16 bar	DN38	39mm	
MACM050PFA-B	SS 1.4404 PFA black coated	16 bar	DN50	50mm	
MACM070PFA-B	SS 1.4404 PFA black coated	16 bar	DN70	70mm	



CONDUCTIVE

LEBENSMITTELINDUSTRIE





90° Macon Mutterteil - Kupplung mit Rillenstutzen und Sicherungsbund (mit Überwurfmutter SS 1.4301)

90° Female Macon serrated shank with collar (with nut)

90° Femelle Macon douille annelée à collerette - avec écrou

90° Hembra Macon con espiga dentada y cuello de seguridad

90° Część Żeńska Macon - z karbowaną końcówką do węża z wiązką zabezpieczającą (nakrętki)

90° Raccordo femmina Macon portagomma con collare di sicurezza (Girella Macon)

NEW

Part-No.	Material	WP	Dimension	Shank	Price
MACF038-90	SS 1.4404	25 bar	DN38	38mm	
MACF050-90	SS 1.4404	25 bar	DN50	50mm	
MACF070-90	SS 1.4404	25 bar	DN70	70mm	



90° Macon Vaterteil - Kupplung mit Rillenstutzen und Sicherungsbund (ohne Dichtung)

90° Male Macon serrated shank with collar (without gasket)

90° Mâle Macon douille annelée à collerette

90° Macho Macon con espiga dentada y cuello de seguridad

90° Część Męska z gwintem zewnętrznym Macon z karbowaną końcówką do węża z wiązką zabezpieczającą

90° Raccordo maschio Macon portagomma con collare di sicurezza

NEW

Part-No.	Material	WP	Dimension	Shank	Price
MACM038-90	SS 1.4404	25 bar	DN38	38mm	
MACM050-90	SS 1.4404	25 bar	DN50	50mm	
MACM070-90	SS 1.4404	25 bar	DN70	70mm	



Macon Mutterteil - Kupplung auf BSPP Innengewinde (mit Überwurfmutter SS 1.4301)

Female Macon BSPP female thread

Femelle Macon - Taraudage femelle BSPP

Hembra Macon rosca hembra BSPP

Część Żeńska Macon - Część Męska z gwintem zewnętrznym na końcówkę z gwintem wewnętrznym BSPP

Raccordo femmina Macon filettato femmina

NEW

Part-No.	Material	WP	Dimension	Thread	Price
MACF038IG	SS 1.4404	25 bar	DN38	1 1/2"	
MACF050IG	SS 1.4404	25 bar	DN50	2"	
MACF070IG	SS 1.4404	25 bar	DN70	2 1/2"	



Macon Vaterteil - Kupplung auf BSPP Innengewinde (ohne Dichtung)

Male Macon to BSPP female thread (without gasket)

Mâle Macon - Taraudage femelle BSPP

Macho Macon con rosca hembra BSPP

Część Męska gwintem zewnętrznym na końcówkę z gwintem wewnętrznym BSPP

Raccordo femmina Macon filettatura femmina BSPP



NEW

Part-No.	Material	WP	Dimension	Thread	Price
MACM038IG	SS 1.4404	25 bar	DN38	1 1/2"	
MACM050IG	SS 1.4404	25 bar	DN50	2"	
MACM070iG	SS 1.4404	25 bar	DN70	2 1/2"	

Macon Mutterteil - Kupplung auf BSPP Außengewinde

(mit Überwurfmutter SS 1.4301)

Female Macon BSPP male thread (with nut)

Femelle Macon - Filetage mâle BSPP

Hembra Macon rosca macho BSPP

Część Żeńska Macon - Część Żeńska bez nakrętki na końcówkę z gwintem zewnętrznym BSPP

Raccordo femmina Macon con filettatura maschio BSPP



NEW

Part-No.	Material	WP	Dimension	Thread	Price
MACF038AG	SS 1.4404	25 bar	DN38	1 1/2"	
MACF050AG	SS 1.4404	25 bar	DN50	2"	
MACF070AG	SS 1.4404	25 bar	DN70	2 1/2"	

Macon Vaterteil - Kupplung auf BSPP Außengewinde (ohne Dichtung)

Male Macon to BSPP male thread (without gasket)

Mâle Macon - Filetage mâle BSPP

Macho Macon con rosca macho BSPP

Część Męska Część Żeńska bez nakrętki na końcówkę z gwintem zewnętrznym BSPP

Raccordo maschio Macon con filettatura maschio BSPP



NEW

Part-No.	Material	WP	Dimension	Thread	Price
MACM038AG	SS 1.4404	25 bar	DN38	1 1/2"	
MACM050AG	SS 1.4404	25 bar	DN50	2"	
MACM070AG	SS 1.4404	25 bar	DN70	2 1/2"	





Macon Uberwurfmutter

Macon nut
Ecrou Macon
Tuerca Macon
Nakrętka Macon
Girella Macon

Part-No.	Material	WP	Dimension	Price
MACE038	SS 1.4301	25 bar	DN38	
MACE050	SS 1.4301	25 bar	DN50	
MACE070	SS 1.4301	25 bar	DN70	



Kappe für Macon mit Griff

Macon cap with handle
Bouchon Macon avec poignée
Macon con maneta
Kapsel Macon z uchwytem
Macon con maniglia

NEW

Part-No.	Material	WP	Dimension	Price
MACC038-G	SS 1.4301	25 bar	DN38	
MACC050-G	SS 1.4301	25 bar	DN50	
MACC070-G	SS 1.4301	25 bar	DN70	



Stopfen für Macon mit Griff

Macon plug with handle
Bouchon Macon avec poignée
Macon con maneta
Zaślepka Macon do MK z rączką
Macon con maniglia

NEW

Part-No.	Material	WP	Dimension	Price
MACP038-G	SS 1.4301	25 bar	DN38	
MACP050-G	SS 1.4301	25 bar	DN50	
MACP070-G	SS 1.4301	25 bar	DN70	



Macon Mutterteil mit Anschweißende (ohne Überwurfmutter)

Female Macon with welding end (without DIN nut)

Femelle Macon à souder

Casquillo hembra Macon para soldar

Część żeńska zgodnie Macon z króćcem do dospawania (bez nakrętki)

Bocchettone Macon femmina a saldare



NEW

Part-No.	Material	WP	Dimension	BW (ID x OD)	Price
MACF038BW	SS 1.4301	25 bar	DN38	43,3 x 46,3	
MACF050BW	SS 1.4301	25 bar	DN50	53,3 x 56,3	
MACF070BW	SS 1.4301	25 bar	DN70	73,3 x 76,3	

Außengewinde nach DIN 11851 mit Anschweißende (BW) (ohne Dichtung)

Male Macon with welding end (without gasket)

Mâle Macon à souder

Casquillo macho Macon para soldar (sin junta)

Część męska z gwintem zewnętrznym zgodnie Macon z króćcem do spawania (bez uszczelki)

Bocchettone Macon maschio a saldare



NEW

Part-No.	Material	WP	Dimension	BW (ID x OD)	Price
MACM038BW	SS 1.4301	25 bar	DN38	43,3 x 46,3	
MACM050BW	SS 1.4301	25 bar	DN50	53,3 x 56,3	
MACM070BW	SS 1.4301	25 bar	DN70	73,3 x 76,3	

Adapter Macon Kupplung auf Übergangsstück Vaterteil DIN 11851

Macon Male coupling to adapter DIN male

Adaptateur mâle Macon avec DIN mâle

Adaptador Macho Macon con Macho DIN 11851

Adapter DIN 11851 - Część żeńska Macon / Wtyk Część męska DIN 11851

Adattatore Maschio Macon con Maschio DIN 11851



Part-No.	Material	WP	DINHM	Macon	Price
DINHM40MACM38	SS 1.4404	25 bar	DN40	DN38	
DINHM50MACM50	SS 1.4404	25 bar	DN50	DN50	
DINHM80MACM70	SS 1.4404	25 bar	DN80	DN70	



Gummi Prallschutz für Macon Überwurfmutter

Rubber protection for Macon nut

Protection d'écrou Macon

Protección para tuerca Macon

Gumowa ochrona przed uderzeniami dla Macon Nakrętki

Protezione per girella Macon



Part-No.	Colour	Material	Shore°	DN	Price
MACE038B	Blue	EPDM	60	DN38	
MACE050B	Blue	EPDM	60	DN50	
MACE070B	Blue	EPDM	60	DN70	
MACE038R	Red	EPDM	60	DN38	
MACE050R	Red	EPDM	60	DN50	
MACE070R	Red	EPDM	60	DN70	
MACE038S	Black	EPDM	60	DN38	
MACE050S	Black	EPDM	60	DN50	
MACE070S	Black	EPDM	60	DN70	
MACE038W	White	EPDM	60	DN38	
MACE050W	White	EPDM	60	DN50	
MACE070W	White	EPDM	60	DN70	





SCHLAUCH- VERSCHRAUBUNG

Schalenverschraubung.....	300
Kombination Nippel.....	318

INFORMATIONEN

Schalenverschraubungen EN 14420



Die Verbindung zwischen Schlauch und Fitting-Armaturen muss höchsten Ansprüchen genügen. Trotz Belastungen durch Druck, Temperatur und deren Schwankungen soll die Verbindung sicherer sein als der Schlauch selbst.

Für innen folienbeschichtete Schläuche empfiehlt sich der Einsatz von Rippenstützen, während bei Linern aus Elastomeren sowohl glatte als auch gerippte

Stützen verwendet werden können.

Die jahrzehntelange Optimierung der DIN EN 14420 hat gezeigt, dass die konsequente Einhaltung dieser Norm unerlässlich ist. Eine optimale Abstimmung zwischen Klemmschale und Fitting ist dabei für eine gute Einbindung entscheidend.

Aus diesem Grund ist es ratsam, Klemmschalen und Armaturen aus

einer Hand zu beziehen. Die Praxis zeigt jedoch, dass Toleranzen in der Schlauchwanddicke und die teils geringere Zeitstandsfestigkeit von Elastomeren zu Undichtigkeiten führen können.

Um diesem Risiko zu vermeiden, sollte das System aus Klemmschale und Fitting durch die gezielte Nutzung der in der Norm definierten Toleranzen optimiert werden.



WARUM MCC?

- Optimierte Stützen und Klemmschalen
- Die auf Folienliner ausgelegte Rippenstruktur sorgt für verbesserte Dichtigkeit
- Konsequente Einhaltung der Normreihe DIN EN 14420
- Feinkörnige und duktile Edelstahl, Aluminium- und Messingwerkstoffe
- Für weitere Anschlussmöglichkeiten Stützen mit Anschweißende verfügbar
- Auf MCC-Klemmschalen und Pressfassungen optimiert
- Konsequente entgrateter Stützen Bereich, um Liner nicht zu beschädigen
- Dicke PFA-Auskleidung für Metall angreifende Chemikalien (auch in Ω)
- Rohrkrümmer zur Vermeidung von Abknicken Nähe der Rohrleitung

TECHNISCHE INFORMATIONEN

- Norm:
DIN EN 14402-2 in Abstimmung auf die DIN EN 14420-3
- Nennweiten:
DN13- DN100 (Stahl ohne Sicherungsbund bis DN200)
- Dickwand PFA mit FDA (auch in Ω) und für Fe3CL
- Werkstoffe:
Edelstahl, Aluminium, Stahl, Messing und Polypropylen
- Sechskant und Hackenschlüssel Ansatz

EINSATZGEBIET

Nahezu universeller Standard in der Chemie und Anlagentechnik für Elastomer Schläuche nach DIN EN 12115. Stützen und Klemmschalen lassen sich demonstrieren, was durch Wiederverwendung die Nachhaltigkeit unterstützt. Dieses System kann „vor Ort“ montiert werden, so dass sich auch geknickte Schläuche einkürzen lassen.





INFORMATION

Hose Shanks EN 14420

The connection between the hose and couplings must meet the highest standards. Despite the stresses caused by pressure, temperature and their fluctuations, the connection should be more secure than the hose itself.

For internally foil-coated hoses, the use of serrated connectors is recommended, while both smooth and ribbed connectors can be used for elastomer liners.

Decades of optimization of DIN EN 14420 have shown that consistent compliance with this standard is essential. Optimum coordination between the safety clamp and fitting is crucial for a good connection.

For this reason, it is advisable to purchase clamping shells and fittings from a single source. However, practical experience shows that tolerances in the

hose wall thickness and the sometimes lower creep strength of elastomers can lead to leaks.

To avoid this risk, the system of clamping shell and fitting should be optimized by making targeted use of the tolerances defined in the standard.

WHY MCC?

- Optimized hose shank and safety clamps
- The serrated structure designed for foil liners ensures improved tightness
- Consistent compliance with the DIN EN 14420 series of standards
- Fine-grained and ductile stainless steel, aluminum and brass materials
- Weld-on available for other connection options
- Optimized for MCC safety clamps and crimping ferrules
- Consistently deburred hose shank to avoid damaging the liner
- Thick PFA lining for aggressive liquids that attack metal (also conductive)
- Pipe elbow to prevent kinking near the pipeline



TECHNICAL INFORMATION

- Norm:
DIN EN 14402-2 in coordination with
DIN EN 14420-3
- Size:
DN13- DN100 (steel without safety
collar up to DN200
- Thick lined PFA with FDA (also in Ω)
and for Fe3CL
- Materials:
Stainless steel, aluminum, steel,
brass and polypropylene
- Hexagon and hook wrench
attachment

AREA OF APPLICATION

Almost universal standard in chemical and plant engineering for elastomer hoses according to DIN EN 12115. Spigots and clamping shells can be removed, which supports sustainability through reuse. This system can be assembled "on site" so that even kinked hoses can be shortened.

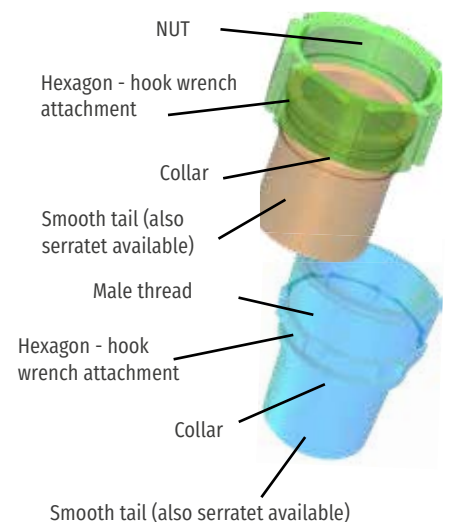



Vaterteil Schalenverschraubung mit glattem Stutzen und Sicherungsbund

Male BSPP thread EN14420-2 smooth hose shank and collar

Raccord mâle douille lisse à colerette BSPP EN 14420-2

Acople rosca macho BSPP EN 14420-2 con espiga lisa y cuello de seguridad

Część Męska z gwintem zewnętrznym BSPP z gładką końcówką do węży z wiązką zabezpieczającą

Raccordo filettato maschio BSPP EN 14420-2 con portagomma liscio e collare di sicurezza

Part-No.	Material	WP	Shank	Thread	Price
SMSS13	SS 1.4408	25 bar	DN13	1/2"	
SMSS19	SS 1.4408	25 bar	DN19	3/4"	
SMSS25	SS 1.4408	25 bar	DN25	1"	
SMSS2550	SS 1.4408	25 bar	DN25	2"	
SMSS32	SS 1.4408	25 bar	DN32	1 1/4"	
SMSS38	SS 1.4408	25 bar	DN38	1 1/2"	
SMSS50	SS 1.4408	25 bar	DN50	2"	
SMSS5075	SS 1.4408	25 bar	DN50	3"	
SMSS65	SS 1.4408	25 bar	DN63	2 1/2"	
SMSS6575	SS 1.4408	25 bar	DN63	3"	
SMSS75	SS 1.4408	25 bar	DN75	3"	
SMSS75100	SS 1.4408	25 bar	DN75	4"	
SMSS100	SS 1.4408	25 bar	DN100	4"	



Vaterteil Schalenverschraubung mit gerilltem Stutzen und Sicherungsbund

Male BSPP thread EN14420-2 serrated hose shank and collar

Raccord mâle douille annelée à collerette BSPP EN 14420-2

Acople rosca macho BSPP EN 14420-2 con espiga dentada y cuello de seguridad

Część Męska z gwintem zewnętrznym BSPP z karbowaną końcówką do węża z wiązką zabezpieczającą

Raccordo filettato maschio BSPP EN 14420-2 con portagomma a resca e collare di sicurezza



Part-No.	Material	WP	Shank	Thread	Price
SMSS13S	SS 1.4408	25 bar	DN13	1/2"	
SMSS19S	SS 1.4408	25 bar	DN19	3/4"	
SMSS25S	SS 1.4408	25 bar	DN25	1"	
SMSS2550S	SS 1.4408	25 bar	DN25	2"	
SMSS32S	SS 1.4408	25 bar	DN32	1 1/4"	
SMSS38S	SS 1.4408	25 bar	DN38	1 1/2"	
SMSS50S	SS 1.4408	25 bar	DN50	2"	
SMSS5075S	SS 1.4408	25 bar	DN50	3"	
SMSS65S	SS 1.4408	25 bar	DN63	2 1/2"	
SMSS75S	SS 1.4408	25 bar	DN75	3"	
SMSS75100S	SS 1.4408	25 bar	DN75	4"	
SMSS100S	SS 1.4408	25 bar	DN100	4"	





Vaterteil Schalenverschraubung mit gerilltem Stutzen und Sicherungsbund

NPT Gewinde

Male NPT thread EN14420-2 serrated hose shank and collar

Raccord mâle douille annelée à collerette NPT EN 14420-2

Acople rosca macho NPT EN 14420-2 con espiga dentada y cuello de seguridad

Część Męska z gwintem zewnętrznym NPT z karbowaną końcówką do węża z wiązką zabezpieczającą

Raccordo filettato maschio NPT EN 14420-2 con portagomma a resca e collare di sicurezza

Part-No.	Material	WP	Shank	Thread	Price
SMSS13S-NPT	SS 1.4408	25 bar	DN13	1/2"	
SMSS19S-NPT	SS 1.4408	25 bar	DN19	3/4"	
SMSS25S-NPT	SS 1.4408	25 bar	DN25	1"	
SMSS32S-NPT	SS 1.4408	25 bar	DN32	1 1/4"	
SMSS38S-NPT	SS 1.4408	25 bar	DN38	1 1/2"	
SMSS50S-NPT	SS 1.4408	25 bar	DN50	2"	
SMSS75S-NPT	SS 1.4408	25 bar	DN75	3"	



90° Vaterteil Schalenverschraubung mit gerilltem Stutzen und Sicherungsbund

90° Male BSPP thread EN14420-2 serrated hose shank and collar

90° Raccord mâle douille annelée à collerette BSPP EN 14420-2

90° Acople rosca macho BSPP EN 14420-2 con espiga dentada y cuello de seguridad

90° Część Męska z gwintem zewnętrznym BSPP z karbowaną końcówką do węża z wiązką zabezpieczającą

90° Raccordo filettato maschio BSP EN 14420-2 con portagomma a resca e collare di sicurezza

Part-No.	Material	WP	Shank	Thread	Price
SMSS25S-90	SS 1.4408	25 bar	DN25	1"	
SMSS32S-90	SS 1.4408	25 bar	DN32	1 1/4"	
SMSS38S-90	SS 1.4408	25 bar	DN38	1 1/2"	
SMSS50S-90	SS 1.4408	25 bar	DN50	2"	
SMSS65S-90	SS 1.4408	25 bar	DN63	2 1/2"	
SMSS75S-90	SS 1.4408	25 bar	DN75	3"	



45° Vaterteil Schalenverschraubung mit gerilltem Stutzen und Sicherungsbund

45° Male BSPP thread EN14420-2 serrated hose shank and collar

45° Raccord mâle douille annelée à collerette BSPP EN 14420-2

45° Acople rosca macho BSPP EN 14420-2 con espiga dentada y cuello de seguridad

45° Część Męska z gwintem zewnętrznym BSPP z karbowaną końcówką do węża z wiązką zabezpieczającą

45° Raccordo filettato maschio BSP EN 14420-2 con portagomma a resca e collare di sicurezza



Part-No.	Material	WP	Shank	Thread	Price
SMSS25S-45	SS 1.4408	25 bar	DN25	1"	
SMSS32S-45	SS 1.4408	25 bar	DN32	1 1/4"	
SMSS38S-45	SS 1.4408	25 bar	DN38	1 1/2"	
SMSS50S-45	SS 1.4408	25 bar	DN50	2"	
SMSS65S-45	SS 1.4408	25 bar	DN63	2 1/2"	
SMSS75S-45	SS 1.4408	25 bar	DN75	3"	



Vaterteil Schalenverschraubung mit gerilltem Stutzen und Sicherungsbund

PFA ausgekleidet

Male BSPP thread serrated hose shank and collar - PFA coated

Raccord mâle douille annelée à collerette BSPP - Revêtu de PFA

Acople rosca macho BSPP EN 14420-2 con espiga dentada recubierta en PFA

Część Męska z gwintem zewnętrznym BSPP z karbowaną końcówką do węża z wiązką zabezpieczającą - Z powłoką PFA

Accoppiamento filettato maschio BSPP EN 14420-2 con rivestimento in PFA

NEW

CONDUCTIVE

Part-No.	Material	WP	Shank	Thread	Price
SMSS25SPFA-W	SS 1.4408 PFA white coated	25 bar	DN25	1"	
SMSS32SPFA-W	SS 1.4408 PFA white coated	25 bar	DN32	1 1/4"	
SMSS38SPFA-W	SS 1.4408 PFA white coated	25 bar	DN38	1 1/2"	
SMSS50SPFA-W	SS 1.4408 PFA white coated	25 bar	DN50	2"	
SMSS65SPFA-W	SS 1.4408 PFA white coated	25 bar	DN63	2 1/2"	
SMSS75SPFA-W	SS 1.4408 PFA white coated	25 bar	DN75	3"	
SMSS100SPFA-W	SS 1.4408 PFA white coated	25 bar	DN100	4"	
SMSS25SPFA-B	SS 1.4408 PFA black coated	25 bar	DN25	1"	
SMSS32SPFA-B	SS 1.4408 PFA black coated	25 bar	DN32	1 1/4"	
SMSS38SPFA-B	SS 1.4408 PFA black coated	25 bar	DN38	1 1/2"	
SMSS50SPFA-B	SS 1.4408 PFA black coated	25 bar	DN50	2"	
SMSS65SPFA-B	SS 1.4408 PFA black coated	25 bar	DN63	2 1/2"	
SMSS75SPFA-B	SS 1.4408 PFA black coated	25 bar	DN75	3"	



Mutterteil Schalenverschraubung mit glattem Stutzen und Sicherungsbund mit PTFE Dichtung

Female BSPP thread EN14420-2 smooth hose shank and collar - PTFE gasket

Raccord femelle à écrou BSP tournant et fond plat à douille lisse et collerette DIN2817 - joint PTFE

Acople rosca hembra BSPP EN 14420-2 con espiga lisa, cuello de seguridad y tuerca loca - Junta PTFE

Część żeńska z gwintem wewnętrznym BSPP (dwuczęściowa ze Śrubunkiem) z gładką końcówką do węża z wiązką zabezpieczającą - Uszczelka PTFE

Accoppiamento filettato femmina BSPP EN 14420-2 con portagomma liscio, collare di sicurezza e girella - Guarnizione PTFE



Part-No.	Material	WP	Shank	Thread	Price
SFSS13	SS 1.4408	25 bar	DN13	1/2"	
SFSS19	SS 1.4408	25 bar	DN19	3/4"	
SFSS25	SS 1.4408	25 bar	DN25	1"	
SFSS32	SS 1.4408	25 bar	DN32	1 1/4"	
SFSS38	SS 1.4408	25 bar	DN38	1 1/2"	
SFSS50	SS 1.4408	25 bar	DN50	2"	
SFSS65	SS 1.4408	25 bar	DN63	2 1/2"	
SFSS75	SS 1.4408	25 bar	DN75	3"	
SFSS100	SS 1.4408	25 bar	DN100	4"	





Mutterteil Schalenverschraubung mit gerilltem Stutzen und Sicherungsbund mit PTFE Dichtung

Female BSPP thread EN14420-2 serrated hose shank and collar - PTFE gasket

Raccord femelle à écrou BSP tournant et fond plat à douille annelée et collerette DIN2817 - joint PTFE

Acople rosca hembra BSPP EN 14420-2 con espiga dentada, cuello de seguridad y tuerca loca - Junta PTFE

Część żeńska z gwintem wewnętrznym BSPP (dwuczęściowa ze Śrubunkiem) z karbowaną końcówką do węża z wiązką zabezpieczającą

Accoppiamento filettato femmina BSPP EN 14420-2 con portagomma, collare di sicurezza e girella

Part-No.	Material	WP	Shank	Thread	Price
SFSS13S	SS 1.4408	25 bar	DN13	1/2"	
SFSS19S	SS 1.4408	25 bar	DN19	3/4"	
SFSS25S	SS 1.4408	25 bar	DN25	1"	
SFSS32S	SS 1.4408	25 bar	DN32	1 1/4"	
SFSS38S	SS 1.4408	25 bar	DN38	1 1/2"	
SFSS50S	SS 1.4408	25 bar	DN50	2"	
SFSS65S	SS 1.4408	25 bar	DN63	2 1/2"	
SFSS75S	SS 1.4408	25 bar	DN75	3"	
SFSS100S	SS 1.4408	25 bar	DN100	4"	

90° Mutterteil Schalenverschraubung mit gerilltem Stutzen und Sicherungsbund mit PTFE Dichtung

90° Female BSPP thread EN14420-2 serrated hose shank and collar - PTFE gasket

90° Raccord femelle à écrou BSP tournant et fond plat à douille annelée et collerette DIN2817 - joint PTFE

90° Acople rosca hembra BSPP EN 14420-2 con espiga dentada y cuello de seguridad - Junta PTFE

90° Część żeńska z gwintem wewnętrznym BSPP (dwuczęściowa ze Śrubunkiem) z karbowaną końcówką do węża z wiązką zabezpieczającą - Uszczelka PTFE

90° Raccordo filettato femmina BSP EN 14420-2 con portagomma a resca e collare di sicurezza - guarnizione PTFE

Part-No.	Material	WP	Shank	Thread	Price
SFSS25S-90	SS 1.4408	25 bar	DN25	1"	
SFSS32S-90	SS 1.4408	25 bar	DN32	1 1/4"	
SFSS38S-90	SS 1.4408	25 bar	DN38	1 1/2"	
SFSS50S-90	SS 1.4408	25 bar	DN50	2"	
SFSS65S-90	SS 1.4408	25 bar	DN63	2 1/2"	
SFSS75S-90	SS 1.4408	25 bar	DN75	3"	



45° Mutterteil Schalenverschraubung mit gerilltem Stutzen und Sicherungsbund mit PTFE Dichtung

45° Female BSPP thread EN14420-2 serrated hose shank and collar - PTFE gasket

45° Raccord femelle à écrou BSP tournant et fond plat à douille annelée et collerette DIN2817 - joint PTFE

45° Acople rosca hembra BSPP EN 14420-2 con espiga dentada y cuello de seguridad - Junta PTFE

45° Część Żeńska z gwintem wewnętrznym BSPP (dwuczęściowa ze Śrubunkiem) z karbowaną końcówką do węży z wiązką zabezpieczającą - Uszczelka PTFE

45° Raccordo filettato femmina BSP EN 14420-2 con portagomma a resca e collare di sicurezza - guarnizione PTFE



Part-No.	Material	WP	Shank	Thread	Price
SFSS25S-45	SS 1.4408	25 bar	DN25	1"	
SFSS32S-45	SS 1.4408	25 bar	DN32	1 1/4"	
SFSS38S-45	SS 1.4408	25 bar	DN38	1 1/2"	
SFSS50S-45	SS 1.4408	25 bar	DN50	2"	
SFSS65S-45	SS 1.4408	25 bar	DN63	2 1/2"	
SFSS75S-45	SS 1.4408	25 bar	DN75	3"	

Gewindekappe mit BSPP Innengewinde mit PTFE Dichtung

Cap with female BSPP thread - PTFE gasket

Bouchon fileté - joint PTFE

Tapón con rosca hembra BSPP - Junta PTFE

Pokrywka z gwintem wewnętrznym BSPP - Uszczelka PTFE

Tappo con filettatura femmina BSPP - Guarnizione PTFE



Part-No.	Material	WP	Thread	Price
BC050SS	SS 1.4408 (Chain SS 301)	25 bar	1/2"	
BC075SS	SS 1.4408 (Chain SS 301)	25 bar	3/4"	
BC100SS	SS 1.4408 (Chain SS 301)	25 bar	1"	
BC150SS	SS 1.4408 (Chain SS 301)	25 bar	1 1/2"	
BC200SS	SS 1.4408 (Chain SS 301)	25 bar	2"	
BC250SS	SS 1.4408 (Chain SS 301)	25 bar	2 1/2"	
BC300SS	SS 1.4408 (Chain SS 301)	25 bar	3"	





Vaterteil Schalenverschraubung mit glattem Stutzen und Sicherungsbund

Male BSPP thread EN14420-2 smooth hose shank and collar

Raccord mâle douille lisse à colerette BSPP EN 14420-2

Acople rosca macho BSPP EN 14420-2 con espiga lisa y cuello de seguridad

Część Męska z gwintem zewnętrznym BSPP z gładką końcówką do węży z wiązką zabezpieczającą

Raccordo filettato maschio BSPP EN 14420-2 con portagomma liscio e collare di sicurezza

Part-No.	Material	WP	Shank	Thread	Price
SMBR13	BR / CW617N	25 bar	DN13	1/2"	
SMBR19	BR / CW617N	25 bar	DN19	3/4"	
SMBR25	BR / CW617N	25 bar	DN25	1"	
SMBR32	BR / CW617N	25 bar	DN32	1 1/4"	
SMBR38	BR / CW617N	25 bar	DN38	1 1/2"	
SMBR3850	BR / CW617N	25 bar	DN38	2"	
SMBR50	BR / CW617N	25 bar	DN50	2"	
SMBR5075	BR / CW617N	25 bar	DN50	3"	
SMBR65	BR / CW617N	25 bar	DN63	2 1/2"	
SMBR6575	BR / CW617N	25 bar	DN63	3"	
SMBR75	BR / CW617N	25 bar	DN75	3"	
SMBR80	BR / CW617N	25 bar	DN80	3"	
SMBR75100	BR / CW617N	25 bar	DN75	4"	
SMBR100	BR / CW617N	25 bar	DN100	4"	



Vaterteil Schalenverschraubung mit gerilltem Stutzen und Sicherungsbund

Male BSPP thread EN14420-2 serrated hose shank and collar

Raccord mâle douille annelée à collerette BSPP EN 14420-2

Acople rosca macho BSPP EN 14420-2 con espiga dentada y cuello de seguridad

Część Męska z gwintem zewnętrznym BSPP z karbowaną końcówką do węży z wiązką zabezpieczającą

Raccordo filettato maschio BSPP EN 14420-2 con portagomma a resca e collare di sicurezza



Part-No.	Material	WP	Shank	Thread	Price
SMBR13S	BR / CW617N	25 bar	DN13	1/2"	
SMBR19S	BR / CW617N	25 bar	DN19	3/4"	
SMBR25S	BR / CW617N	25 bar	DN25	1"	
SMBR32S	BR / CW617N	25 bar	DN32	1 1/4"	
SMBR38S	BR / CW617N	25 bar	DN38	1 1/2"	
SMBR50S	BR / CW617N	25 bar	DN50	2"	
SMBR65S	BR / CW617N	25 bar	DN63	2 1/2"	
SMBR75S	BR / CW617N	25 bar	DN75	3"	
SMBR100S	BR / CW617N	25 bar	DN100	4"	





Mutterteil Schalenverschraubung mit glattem Stutzen und Sicherungsbund mit NBR Dichtung

Female BSPP thread EN14420-2 smooth hose shank and collar - NBR gasket

Raccord femelle à écrou BSP tournant et fond plat à douille lisse et collerette DIN2817 - joint NBR

Acople rosca hembra BSPP EN 14420-2 con espiga dentada, cuello de seguridad y tuerca loca - Junta NBR

Część żeńska z gwintem wewnętrznym BSPP (dwuczęściowa ze Śrubunkiem) z gładką końcówką do węża z wiązką zabezpieczającą - Uszczelka NBR

Raccordo filettato femmina BSPP EN 14420-2 con portagomma liscio, collare di sicurezza e girella - Guarnizione NBR

Part-No.	Material	WP	Shank	Thread	Price
SFBR13	BR / CW617N	25 bar	DN13	1/2"	
SFBR19	BR / CW617N	25 bar	DN19	3/4"	
SFBR25	BR / CW617N	25 bar	DN25	1"	
SFBR32	BR / CW617N	25 bar	DN32	1 1/4"	
SFBR3238	BR / CW617N	25 bar	DN32	1 1/2"	
SFBR38	BR / CW617N	25 bar	DN38	1 1/2"	
SFBR3850	BR / CW617N	25 bar	DN38	2"	
SFBR50	BR / CW617N	25 bar	DN50	2"	
SFBR65	BR / CW617N	25 bar	DN63	2 1/2"	
SFBR6575	BR / CW617N	25 bar	DN63	3"	
SFBR75	BR / CW617N	25 bar	DN75	3"	
SFBR100	BR / CW617N	25 bar	DN100	4"	



Mutterteil Schalenverschraubung mit gerilltem Stutzen und Sicherungsbund mit NBR Dichtung

Female BSPP thread EN14420-2 serrated hose shank and collar - NBR gasket

Raccord femelle à écrou BSP tournant et fond plat à douille annelée et collerette DIN2817 - joint NBR

Acople rosca hembra BSPP EN 14420-2 con espiga dentada, cuello de seguridad y tuerca loca - Junta NBR

Część żeńska z gwintem wewnętrznym BSPP (dwuczęściowa ze Śrubunkiem) z karbowaną końcówką do węża z wiązką zabezpieczającą - Uszczelka NBR

Raccordo filettato femmina BSPP EN 14420-2 con portagomma a resca e collare di sicurezza e girella- Guarnizione NBR



Part-No.	Material	WP	Shank	Thread	Price
SFBR13S	BR / CW617N	25 bar	DN13	1/2"	
SFBR19S	BR / CW617N	25 bar	DN19	3/4"	
SFBR25S	BR / CW617N	25 bar	DN25	1"	
SFBR32S	BR / CW617N	25 bar	DN32	1 1/4"	
SFBR38S	BR / CW617N	25 bar	DN38	1 1/2"	
SFBR50S	BR / CW617N	25 bar	DN50	2"	
SFBR65S	BR / CW617N	25 bar	DN63	2 1/2"	
SFBR75S	BR / CW617N	25 bar	DN75	3"	
SFBR100S	BR / CW617N	25 bar	DN100	4"	





Vaterteil Schalenverschraubung mit gerilltem Stutzen und Sicherungsbund

Male BSPP thread serrated hose shank and collar

Raccord mâle douille annelée à collerette BSPP

Acople rosca macho BSPP con espiga dentada y cuello de seguridad

Część Męska z gwintem zewnętrznym BSPP z karbowaną końcówką do węży z wiązką zabezpieczającą

Accoppiamento filettatura maschio BSPP con portagomma a resca e collare di sicurezza

Part-No.	Material	WP	Shank	Thread	Price
SMPP25S	Polypropylene	8 bar	DN25	1"	
SMPP32S	Polypropylene	6 bar	DN32	1 1/4"	
SMPP38S	Polypropylene	6 bar	DN38	1 1/2"	
SMPP50S	Polypropylene	6 bar	DN50	2"	
SMPP75S	Polypropylene	6 bar	DN75	3"	



Vaterteil Schalenverschraubung mit gerilltem Stutzen und Sicherungsbund

Male BSPP thread serrated hose shank and collar

Raccord mâle douille annelée à collerette BSPP

Acople rosca macho BSPP con espiga dentada y cuello de seguridad

Część Męska z gwintem zewnętrznym BSPP z karbowaną końcówką do węży z wiązką zabezpieczającą

Accoppiamento filettatura maschio BSPP con portagomma a resca e collare di sicurezza

NEW

Part-No.	Material	WP	Shank	Thread	Price
SMAL25S	Aluminum	16 bar	DN25	1"	
SMAL38S	Aluminum	16 bar	DN38	1 1/2"	
SMAL50S	Aluminum	16 bar	DN50	2"	
SMAL65S	Aluminum	16 bar	DN65	2 1/2"	
SMAL75S	Aluminum	16 bar	DN75	3"	
SMAL100S	Aluminium	16 bar	DN100	4"	



Reduzierung IG/IG - mit kurzem Gewinde

Reduction female BSPP thread - with short thread

Réduction double femelle/femelle - avec filetage court

Reducción rosca hembra BSPP - con rosca corta

Redukcja z gwintami - z krótkim gwintem

Riduzione filettato femmina BSPP - con filo corto



Part-No.	Material	WP	Thread1	Thread 2	Price
FFA2015	Aluminum	16 bar	2"	1 1/2"	
FFA2515	Aluminum	16 bar	2 1/2"	1 1/2"	
FFA2520	Aluminum	16 bar	2 1/2"	2"	
FFA3015	Aluminum	16 bar	3"	1 1/2"	
FFA3020	Aluminum	16 bar	3"	2"	
FFA3025	Aluminum	16 bar	3"	2 1/2"	
FFA4015	Aluminum	16 bar	4"	1 1/2"	
FFA4020	Aluminum	16 bar	4"	2"	
FFA4025	Aluminum	16 bar	4"	2 1/2"	
FFA4030	Aluminum	16 bar	4"	3"	



PVC Gewindeschutzkappe

PVC thread protection cap

Capuchon de protection en PVC

Tapa protectora de PVC

Nakładka ochronna z PVC

Cappuccio di protezione in PVC



Part-No.	Colour	Material	Dimension	Price
CAP050PVC-B	Blue	PVC	1/2"	
CAP075PVC-B	Blue	PVC	3/4"	
CAP100PVC-B	Blue	PVC	1"	
CAP125PVC-B	Blue	PVC	1 1/4"	
CAP150PVC-B	Blue	PVC	1 1/2"	
CAP200PVC-B	Blue	PVC	2"	
CAP250PVC-B	Blue	PVC	2 1/2"	
CAP300PVC-B	Blue	PVC	3"	
CAP400PVC-B	Blue	PVC	4"	
CAP050PVC-T	Transparent	PVC	1/2"	
CAP075PVC-T	Transparent	PVC	3/4"	
CAP100PVC-T	Transparent	PVC	1"	
CAP125PVC-T	Transparent	PVC	1 1/4"	
CAP150PVC-T	Transparent	PVC	1 1/2"	
CAP200PVC-T	Transparent	PVC	2"	
CAP250PVC-T	Transparent	PVC	2 1/2"	
CAP300PVC-T	Transparent	PVC	3"	
CAP400PVC-T	Transparent	PVC	4"	



90° Bogen AG/AG BSPP flachdichtend

90° elbow male BSPP thread - flat sealing

90° Coude mâle/mâle à joint plat

Codo 90° RM-RM BSPP

90° Lolanoz gwintami zewnętrznymi cylindrycznymi

Curva 90° maschio - maschio BSPP

Part-No.	Material	WP	Thread1	Thread 2	Price
MMA2020FL-90	Aluminum	10 bar	2"	2"	
MMA3030FL-90	Aluminum	10 bar	3"	3"	
MMA4040FL-90	Aluminum	10 bar	4"	4"	
MMS075075FL-90	SS 316	16 bar	3/4"	3/4"	
MMS1010FL-90	SS 316	16 bar	1"	1"	
MMS1212FL-90	SS 316	16 bar	1 1/4"	1 1/4"	
MMS1515FL-90	SS 316	16 bar	1 1/2"	1 1/2"	
MMS2020FL-90	SS 316	16 bar	2"	2"	
MMS3030FL-90	SS 316	16 bar	3"	3"	
MMS4040FL-90	SS 316	16 bar	4"	4"	



**«King» Nippel - für Schelleneinband - BSPT Außengewinde**

nicht flachdichtend

KC nipple - for wire binding - male thread - not flat sealing

Raccord KC mâle BSP à douille annelée sans collerette

Reductor rosca macho - manguera

Końcówka typu CN (KCN, King Combination Nipple) z gwintem zewnętrznym BSPT - do mocowania opaskami - NIE płasko uszczelniana

Ugello KC per fili di collegamento - filettatura maschio - Senza guarnizione piatta

Part-No.	Material	WP	1 Thread	2 Shank	Price
KC050S	SS 304	10 bar	1/2"	13,8mm	
KC075S	SS 304	10 bar	3/4"	20mm	
KC100S	SS 304	10 bar	1"	26mm	
KC125S	SS 304	10 bar	1 1/4"	32,3mm	
KC150S	SS 304	10 bar	1 1/2"	38,7mm	
KC200S	SS 304	10 bar	2"	51,7mm	
KC250S	SS 304	10 bar	2 1/2"	64,8mm	
KC300S	SS 304	10 bar	3"	77,6mm	
KC400S	SS 304	10 bar	4"	102,9mm	

Schlauchverbinder - für Schelleneinband

Hose connector - for wire binding

Raccord KC Double cannelure

Tubo manguera - manguera

Łącznik do węży typu CN (KCN, King Combination Nipple) - do mocowania opaskami

Ugello KC per fili di collegamento - connettore

Part-No.	Material	WP	1 Shank	2 Shank	Price
SHM050	SS 304	10 bar	13,8mm	13,8mm	
SHM075	SS 304	10 bar	20mm	20mm	
SHM100	SS 304	10 bar	26mm	26mm	
SHM125	SS 304	10 bar	32,3mm	32,3mm	
SHM150	SS 304	10 bar	38,7mm	38,7mm	
SHM200	SS 304	10 bar	51,7mm	51,7mm	
SHM250	SS 304	10 bar	64,8mm	64,8mm	
SHM300	SS 304	10 bar	77,6mm	77,6mm	
SHM400	SS 304	10 bar	102,9mm	102,9mm	

**«King» Nippel - für Schelleneinband - Anschweißende**

KC nipple - for wire binding - with welding end

Raccord KC à souder - Douille annelée sans collerette

Tubo manguera para soldar

Końcówka do spawania typu CN (KCN, King Combination Nipple) do węży - do mocowania opaskami

Ugello KC per fili di collegamento - saldabile

Part-No.	Material	WP	1 (IDxOD)	2 Shank	Price
PKC050S	SS 304	10 bar	16,8 x 21,8	13,8mm	
PKC075S	SS 304	10 bar	22,1 x 27,3	20mm	
PKC100S	SS 304	10 bar	28,6 x 34,2	26mm	
PKC125S	SS 304	10 bar	36,5 x 42,9	32,3mm	
PKC150S	SS 304	10 bar	42,4 x 48,8	38,7mm	
PKC200S	SS 304	10 bar	54,4 x 60,8	51,7mm	
PKC250S	SS 304	10 bar	68,5 x 76,6	64,8mm	
PKC300S	SS 304	10 bar	81,5 x 89,5	77,6mm	
PKC400S	SS 304	10 bar	107 x 115	102,9mm	





Rillenstutzen mit Sicherungsbund und Anschweißende

Serrated hose shank with welding end

Douille annelée à souder avec collerette

Espiga dentada con cuello de seguridad para soldar

Karbowaną końcówką do węża z wiązką zabezpieczającą z króćcem do spawania

Portagomma a saldare

Part-No.	Material	WP	Shank	IDxOD	Price
DAAS100SS	SS 1.4408	16 bar	25mm	28,5 x 33,7	
DAAS125SS	SS 1.4408	16 bar	32mm	37,2 x 42,4	
DAAS150SS	SS 1.4408	16 bar	38mm	43,1 x 48,3	
DAAS200SS	SS 1.4408	16 bar	50mm	54,5 x 60,3	
DAAS250SS	SS 1.4408	16 bar	63mm	70,3 x 76,1	
DAAS300SS	SS 1.4408	16 bar	75mm	82,5 x 88,9	
DAAS400SS	SS 1.4408	16 bar	100mm	107,1 x 114,3	
DAAS600SS	SS 1.4408	10 bar	150mm	159,3 x 168,3	
DAAS800SS	SS 1.4408	6 bar	200m	208,9 x 219,1	

«King» Nippel - für Schelleneinband - BSPT Außengewinde

nicht flachdichtend

KC nipple - for wire binding - male thread - not flat sealing

Raccord KC mâle BSP à douille annelée sans collerette

Reductor rosca macho - manguera

Końcówka typu CN (KCN, King Combination Nipple) z gwintem zewnętrznym BSPT - do mocowania opaskami - NIE płasko uszczelniana

Ugello KC per fili di collegamento - filettatura maschio - Senza guarnizione piatta



Part-No.	Material	WP	1 Thread	2 Shank	Price
KC050	galvanized steel	10 bar	1/2"	13,5mm	
KC075	galvanized steel	10 bar	3/4"	20mm	
KC100	galvanized steel	10 bar	1"	26mm	
KC125	galvanized steel	10 bar	1 1/4"	32mm	
KC150	galvanized steel	10 bar	1 1/2"	39mm	
KC200	galvanized steel	10 bar	2"	51,5mm	
KC250	galvanized steel	10 bar	2 1/2"	64mm	
KC300	galvanized steel	10 bar	3"	77mm	
KC350	galvanized steel	10 bar	3"	90mm	
KC400	galvanized steel	10 bar	4"	102,5mm	
KC500	galvanized steel	10 bar	5"	128mm	
KC600	galvanized steel	10 bar	6"	153,4mm	
KC800	galvanized steel	10 bar	8"	204,8mm	

1



2

Schlauchverbinder - für Schelleneinband

Hose connector - for wire binding

Raccord KC Double cannelure

Tubo manguera - manguera

Łącznik do węży typu CN (KCN, King Combination Nipple) - do mocowania opaskami

Ugello KC per fili di collegamento - connettore

Part-No.	Material	WP	1 Shank	2 Shank	Price
HM050	galvanized steel	10 bar	13,8mm	13,8mm	
HM075	galvanized steel	10 bar	20mm	20mm	
HM100	galvanized steel	10 bar	26mm	26mm	
HM125	galvanized steel	10 bar	32,3mm	32,3mm	
HM150	galvanized steel	10 bar	38,7mm	38,7mm	
HM200	galvanized steel	10 bar	51,7mm	51,7mm	
HM250	galvanized steel	10 bar	64,8mm	64,8mm	
HM300	galvanized steel	10 bar	77,6mm	77,6mm	
HM400	galvanized steel	10 bar	102,9mm	102,9mm	
HM500	galvanized steel	10 bar	128,1mm	128,1mm	
HM600	galvanized steel	10 bar	154mm	154mm	
HM800	galvanized steel	10 bar	205mm	205mm	

«King» Nippel - für Schelleneinband - Anschweißende

KC nipple - for wire binding - with welding end

Raccord KC à souder - Douille annelée sans collerette

Tubo manguera para soldar

Końcówka do spawania typu CN (KCN, King Combination Nipple) do węża - do mocowania opaskami

Ugello KC per fili di collegamento - saldabile



Part-No.	Material	WP	1 (IDxOD)	2 Shank	Price
PKC050	galvanized steel	10 bar	16,8 x 20,5	13,8mm	
PKC075	galvanized steel	10 bar	22,1 x 26,5	20mm	
PKC100	galvanized steel	10 bar	28,6 x 33	26mm	
PKC125	galvanized steel	10 bar	36,5 x 42	32,3mm	
PKC150	galvanized steel	10 bar	42,4 x 48	38,7mm	
PKC200	galvanized steel	10 bar	54,4 x 59,5	51,7mm	
PKC250	galvanized steel	10 bar	64,5 x 72,5	64,3mm	
PKC300	galvanized steel	10 bar	81,5 x 88,5	77,6mm	
PKC400	galvanized steel	10 bar	107 x 113,5	102,9mm	
PKC500	galvanized steel	10 bar	131,1 x 140,1	128,1mm	
PKC600	galvanized steel	10 bar	157,1 x 166,10	154mm	
PKC800	galvanized steel	10 bar	206,5 x 218,5	205mm	



Rillenstutzen mit Sicherungsbund und Anschweißende

Serrated hose shank with welding end

Douille annelée à souder avec collerette

Espiga dentada con cuello de seguridad para soldar

Karbowaną końcówką do węża z wiązką zabezpieczającą z króćcem do spawania

Portagomma a saldare

Part-No.	Material	WP	Shank	IDxOD	Price
DAAS100AC	galvanized steel	16 bar	25mm	28,5 x 33,7	
DAAS125AC	galvanized steel	16 bar	32mm	37,2 x 42,4	
DAAS150AC	galvanized steel	16 bar	38mm	43,1 x 48,3	
DAAS200AC	galvanized steel	16 bar	50mm	54,5 x 60,3	
DAAS250AC	galvanized steel	16 bar	63mm	70,3 x 76,1	
DAAS300AC	galvanized steel	16 bar	75mm	82,5 x 88,9	
DAAS400AC	galvanized steel	16 bar	100mm	107,1 x 114,3	
DAAS600AC	galvanized steel	10 bar	150mm	159,3 x 168,3	
DAAS800AC	galvanized steel	6 bar	200mm	208,9 x 219,1	

A detailed technical drawing of a steam pipe assembly, showing various components like valves, flanges, and pipes. The drawing is rendered in a light, faded style, serving as a background for the text. The text is centered over the drawing.

DAMPFSCHLAUCH ARMATUREN



Dampfschlaucharmatur mit Sicherungsbund nach EN14423 mit Außengewinde mit Faserdichtung

Steam hose coupling (EN14423) - with male thread

Mâle à douille annelée vapeur (EN14423)

Acople macho para manguera de vapor (EN14423)

Złącze do pary z końcówką do węży z wiązką zabezpieczającą zgodnie (EN14423) - z gwintem zewnętrznym

Accoppiamento maschio per tubi di vapore (EN 14423)

Part-No.	Material	WP	Thread	Shank	Price
MV50AC	Steel	18 bar	1/2"	13mm	
MV75AC	Steel	18 bar	3/4"	19mm	
MV100AC	Steel	18 bar	1"	25mm	
MV125AC	Steel	18 bar	1 1/4"	32mm	
MV150AC	Steel	18 bar	1 1/2"	38mm	
MV200AC	Steel	18 bar	2"	51mm	



Dampfschlaucharmatur mit Sicherungsbund nach EN14423 - mit Innengewinde mit Faserdichtung

Steam hose coupling (EN14423) - with female thread- fiber gasket

Femelle à douille annelée vapeur (EN14423) - Joint en fibre

Acople hembra para manguera de vapor (EN14423) - Junta de fibra

Złącze do pary z końcówką do węży z wiązką zabezpieczającą zgodnie (EN14423) - z gwintem wewnętrznym - Uszczelka z włókna

Accoppiamento femmina per tubi di vapore (EN 14423) - Guarnizione in fibra

Part-No.	Material	WP	Thread	Shank	Price
FV50AC	Steel	18 bar	1/2"	13mm	
FV75AC	Steel	18 bar	3/4"	19mm	
FV100AC	Steel	18 bar	1"	25mm	
FV125AC	Steel	18 bar	1 1/4"	32mm	
FV150AC	Steel	18 bar	1 1/2"	38mm	
FV200AC	Steel	18 bar	2"	51mm	

Information: Betriebsdruck 18 bar / bis max. 210° bei Sattedampf / bis max. 120° bei Heißwasser

Information: Working pressure 18 bar / up to 210° saturated steam / up to 120° hot water



Dampfschlaucharmatur m. Losflansch PN 40 mit Sicherungsbund nach EN14423

Swivel flange for steam PN40 (EN14423) with collar

Raccord à bride tournante douille annelée à collerette vapeur (EN14423)

Acople de vapor con brida giratoria PN 40 (EN14423) y cuello de seguridad

Złącze kołnierzowe do pary z końcówką do węży z wiązką zabezpieczającą PN40 (EN14423)

Raccordo vapore con flangia girevole PN 40 (EN14423) e collare di sicurezza

Part-No.	Description	Material	WP	Dimension	Price
FFV050AC-ST	Shank	Steel	18 bar	1/2"	
FFV075AC-ST	Shank	Steel	18 bar	3/4"	
FFV0100AC-ST	Shank	Steel	18 bar	1"	
FFV050AC-FL	Flange	Steel	18 bar	1/2"	
FFV075AC-FL	Flange	Steel	18 bar	3/4"	
FFV0100AC-FL	Flange	Steel	18 bar	1"	



Information: Betriebsdruck 18 bar / bis max. 210° bei Sattdampf / bis max. 120° bei Heißwasser

Information: Working pressure 18 bar / up to 210° saturated steam / up to 120° hot water

Gewinde. für Dampf ab Seite 424
Gewindedichtung ab Seite 419Gasket for steam page 424
Thread gasket page 419

Dampfschlaucharmatur System «Boss»

Steam hose coupling System «Boss»

Raccord vapeur type « Boss »

Racor de vapor tipo «Boss»

System łączenia węży parowych «Boss»

Raccordo per vapore tipo «Boss»



Part-No.	Material	Description	WP	Thread	Shank	Price
SF50	Steel	Set	18 bar	1/2"	13mm	
SF75	Steel	Set	18 bar	3/4"	19mm	
SF100	Steel	Set	18 bar	1"	25mm	
SF125	Steel	Set	18 bar	1 1/4"	32mm	
SF150	Steel	Set	18 bar	1 1/2"	38mm	
SF200	Steel	Set	18 bar	2"	51mm	
FS50	Steel	Shank	18 bar	1/2"	13mm	
FS75	Steel	Shank	18 bar	3/4"	19mm	
FS100	Steel	Shank	18 bar	1"	25mm	
FS125	Steel	Shank	18 bar	1 1/4"	32mm	
FS150	Steel	Shank	18 bar	1 1/2"	38mm	
FS200	Steel	Shank	18 bar	2"	51mm	
WN50	Steel	Wing Nut	18 bar	1/2"	13mm	
WN75	Steel	Wing Nut	18 bar	3/4"	19mm	
WN100	Steel	Wing Nut	18 bar	1"	25mm	
WN125	Steel	Wing Nut	18 bar	1 1/4"	32mm	
WN150	Steel	Wing Nut	18 bar	1 1/2"	38mm	
WN200	Steel	Wing Nut	18 bar	2"	51mm	
FSP50	Steel	Female Adapter	18 bar	1/2"	13mm	
FSP75	Steel	Female Adapter	18 bar	3/4"	19mm	
FSP100	Steel	Female Adapter	18 bar	1"	25mm	
FSP125	Steel	Female Adapter	18 bar	1 1/4"	32mm	
FSP150	Steel	Female Adapter	18 bar	1 1/2"	38mm	
FSP200	Steel	Female Adapter	18 bar	2"	51mm	

Information: Betriebsdruck 18 bar / bis max. 210° bei Sattdampf / bis max. 120° bei Heißwasser

Information: Working pressure 18 bar / up to 210° saturated steam / up to 120° hot water



Dampfschlaucharmatur mit Sicherungsbund - mit Außengewinde

Steam hose coupling male - with male thread

Mâle à douille annelée vapeur

Acople macho para manguera de vapor

Złącze do pary z końcówką do węża z wiązka zabezpieczającą zgodnie - z gwintem zewnętrznym

Accoppiamento maschio per tubi di vapore



Part-No.	Material	WP	Thread	Shank	Price
MS50	Steel	18 bar	1/2"	13mm	
MS75	Steel	18 bar	3/4"	19mm	
MS100	Steel	18 bar	1"	25mm	
MS125	Steel	18 bar	1 1/4"	32mm	
MS150	Steel	18 bar	1 1/2"	39mm	
MS200	Steel	18 bar	2"	51mm	

Klemmschale für Dampfschlaucharmatur System «BOSS»

Safety bolt clamp - System «Boss»

Collier à griffe pour raccord vapeur

Abrazadera tipo «Boss»

Płaszcz zaciskowy do systemu mocowania węży parowych «BOSS»

Semigusci tipo «Boss»



Part-No.	Material	WP	Size min	Size max	Price
BC4	Steel	18 bar	24	27	
BC9	Steel	18 bar	33	38	
BCU9	Steel	18 bar	30	33	
BCU14	Steel	18 bar	39	43	
BCU19	Steel	18 bar	45	53	
BCU24	Steel	18 bar	55	60	
BCU29	Steel	18 bar	63	71	

Information: Betriebsdruck 18 bar / bis max. 210° bei Sattdampf / bis max. 120° bei Heißwasser

Information: Working pressure 18 bar / up to 210° saturated steam / up to 120° hot water

Gewinde. für Dampf ab Seite 424
Gewindedichtung ab Seite 419Gasket for steam
Thread gasketpage 424
page 419



Dampfschlaucharmatur mit Sicherungsbund nach EN14423 mit Außengewinde

Steam hose coupling (EN14423) - with male thread

Mâle à douille annelée vapeur (EN14423)

Acople macho para manguera de vapor (EN14423)

Złącze do pary z końcówką do węża z wiązką zabezpieczającą zgodnie (EN14423) - z gwintem zewnętrznym

Accoppiamento maschio per tubi di vapore (EN 14423)

Part-No.	Material	WP	Thread	Shank	Price
MV50SS	SS 304	18 bar	1/2"	13mm	
MV75SS	SS 304	18 bar	3/4"	19mm	
MV100SS	SS 304	18 bar	1"	25mm	
MV125SS	SS 304	18 bar	1 1/4"	32mm	
MV150SS	SS 304	18 bar	1 1/2"	38mm	
MV200SS	SS 304	18 bar	2"	51mm	



Dampfschlaucharmatur mit Sicherungsbund nach EN14423 - mit Innengewinde mit Faserdichtung

Steam hose coupling (EN14423) - with female thread- fiber gasket

Femelle à douille annelée vapeur (EN14423) - Joint en fibre

Acople macho para manguera de vapor (EN14423) - con rosca Hembra - Junta de fibra

Złącze do pary z końcówką do węża z wiązką zabezpieczającą zgodnie (EN14423) - z gwintem wewnętrznym - Uszczelka z włókna

Accoppiamento maschio per tubi di vapore (EN 14423) - con filettatura Femmina- Guarnizione in fibra

Part-No.	Material	WP	Thread	Shank	Price
FV50SS	SS 304	18 bar	1/2"	13mm	
FV75SS	SS 304	18 bar	3/4"	19mm	
FV100SS	SS 304	18 bar	1"	25mm	
FV125SS	SS 304	18 bar	1 1/4"	32mm	
FV150SS	SS 304	18 bar	1 1/2"	38mm	
FV200SS	SS 304	18 bar	2"	51mm	

Information: Betriebsdruck 18 bar / bis max. 210° bei Sattdampf / bis max. 120° bei Heißwasser

Information: Working pressure 18 bar / up to 210° saturated steam / up to 120° hot water



Dampfschlaucharmatur m. Losflansch PN 40 mit Sicherungsbund nach EN14423

Swivel flange for steam PN40 (EN14423) with collar

Raccord à bride tournante douille annelée à collerette vapeur (EN14423)

Acople de vapor con brida giratoria PN 40 (EN14423) y cuello de seguridad

Złącze kotłnierzowe do pary z końcówką do węzła z wiązką zabezpieczającą PN40 (EN14423)

Raccordo vapore con flangia girevole PN 40 (EN14423) e collare di sicurezza

Part-No.	Description	Material	WP	Dimension	Price
FFV050SS-ST	Shank	SS AISI 316	18 bar	1/2"	
FFV075SS-ST	Shank	SS AISI 316	18 bar	3/4"	
FFV0100SS-ST	Shank	SS AISI 316	18 bar	1"	
FFV0200SS-ST	Shank	SS AISI 316	18 bar	2"	
FFV050SS-FL	Flange	SS AISI 316	18 bar	1/2"	
FFV075SS-FL	Flange	SS AISI 316	18 bar	3/4"	
FFV0100SS-FL	Flange	SS AISI 316	18 bar	1"	
FFV0200SS-FL	Flange	SS AISI 316	18 bar	2"	

**Klemmschale für Dampfschlaucharmaturen nach EN14423**

Safety clamp for steam hose couplings EN14423

Collier demi-coquilles vapeur DIN2826

Abrazadera de seguridad para mangueras de vapor EN14423

Obejma skorupowa do pary zgodnie EN14423

Semigusci per tubi di vapore EN 14423



Part-No.	Material	Hose	Size	Screw	Price
DC13SSV	SS 304 (Screw SS)	13*6	24-26	M6x20	
DC19SSV	SS 304 (Screw SS)	19*7	32-34	M8x25	
DC25SSV	SS 304 (Screw SS)	25*7,5	39-41	M8x25	
DC32SSV	SS 304 (Screw SS)	32*8	47-50	M8x25	
DC38SSV	SS 304 (Screw SS)	38*8	53-56	M10x40	
DC50SSV	SS 304 (Screw SS)	50*9	67-69	M10x40	

Information: Betriebsdruck 18 bar / bis max. 210° bei Sattdampf / bis max. 120° bei Heißwasser

Information: Working pressure 18 bar / up to 210° saturated steam / up to 120° hot water

Gewinde. für Dampf ab Seite 424
Gewindedichtung ab Seite 419Gasket for steam
Thread gasketpage 424
page 419



Dampfschlaucharmatur mit Sicherungsbund nach EN14423 mit Außengewinde

Steam hose coupling (EN14423) - with male thread

Mâle à douille annelée vapeur (EN14423)

Acople macho para manguera de vapor (EN14423)

Złącze do pary z końcówką do węża z wiązką zabezpieczającą zgodnie (EN14423) - z gwintem zewnętrznym

Accoppiamento maschio per tubi di vapore (EN 14423)

Part-No.	Material	WP	Thread	Shank	Price
MV50BR	Brass	18 bar	1/2"	13mm	
MV75BR	Brass	18 bar	3/4"	19mm	
MV100BR	Brass	18 bar	1"	25mm	
MV125BR	Brass	18 bar	1 1/4"	32mm	
MV150BR	Brass	18 bar	1 1/2"	38mm	
MV200BR	Brass	18 bar	2"	51mm	



Dampfschlaucharmatur mit Sicherungsbund nach EN14423 - mit Innengewinde mit Faserdichtung

Steam hose coupling (EN14423) - with female thread- fiber gasket

Femelle à douille annelée vapeur (EN14423) - Joint en fibre

Acople macho para manguera de vapor (EN14423) - Junta de fibra

Złącze do pary z końcówką do węża z wiązką zabezpieczającą zgodnie (EN14423) - z gwintem wewnętrznym - Uszczelka z włókna

Accoppiamento maschio per tubi di vapore (EN 14423) - Guarnizione in fibra

Part-No.	Material	WP	Thread	Shank	Price
FV50BR	Brass	18 bar	1/2"	13mm	
FV75BR	Brass	18 bar	3/4"	19mm	
FV100BR	Brass	18 bar	1"	25mm	
FV125BR	Brass	18 bar	1 1/4"	32mm	
FV150BR	Brass	18 bar	1 1/2"	38mm	
FV200BR	Brass	18 bar	2"	51mm	

Information: Betriebsdruck 18 bar / bis max. 210° bei Sattdampf / bis max. 120° bei Heißwasser

Information: Working pressure 18 bar / up to 210° saturated steam / up to 120° hot water



Klemmschale für Dampfschlaucharmaturen nach EN14423

Safety clamp for steam hose couplings EN14423

Collier demi-coquilles vapeur DIN2826

Abrazadera de seguridad para mangueras de vapor EN14423

Obejma skorupowa do pary zgodnie EN14423

Semigusci per tubi di vapore EN 14423



Part-No.	Material	Hose	Size	Screw	Price
DC13BRV	Brass (Screw SS)	13*6	24-26	M6x20	
DC19BRV	Brass (Screw SS)	19*7	32-34	M8x25	
DC25BRV	Brass (Screw SS)	25*7,5	39-41	M8x25	
DC32BRV	Brass (Screw SS)	32*8	47-50	M8x25	
DC38BRV	Brass (Screw SS)	38*8	53-56	M10x40	
DC50BRV	Brass (Screw SS)	50*9	67-69	M10x40	

Information: Betriebsdruck 18 bar / bis max. 210° bei Sattdampf / bis max. 120° bei Heißwasser

Information: Working pressure 18 bar / up to 210° saturated steam / up to 120° hot water

Gewinde. für Dampf ab Seite 424
Gewindedichtung ab Seite 419Gasket for steam page 424
Thread gasket page 419



PRESSHÜLSEN & KLEMMSCHALEN

Klemmschalen	336
Presshülsen	346
Schlauchschellen.....	356
Schlauchklemme.....	358
MCC Schelle.....	361



Klemmschale nach EN 14420-3 - Schrauben aus Stahl

Safety clamp EN 14420-3 - Screws in steel

Collier demi-coquilles EN 14420-3 - Visserie Acier

Abrazadera de seguridad EN 14420-3 - Tornillos en acero

Obejmy skorupowe skręcane zgodnie EN 14420-3 - Śruby ze stali

Morsetto di sicurezza EN 14420-3 - Viti in acciaio

Part-No.	Material	DN	WP	Hose	Shank	Screw	Price
DC13X5AL	Aluminum	13	25 bar	13*5	22-24	M6x20	
DC19X6AL	Aluminum	19	25 bar	19*6	30-33	M6x20	
DC25X5AL*	Aluminum	25	25 bar	25*5	34-36	M6x20	
DC25X6AL	Aluminum	25	25 bar	25*6	36-39	M6x20	
DC25X8AL*	Aluminum	25	25 bar	25*8	40-43	M6x20	
DC32X5AL*	Aluminum	32	25 bar	32*5	41-43	M6x20	
DC32X6AL	Aluminum	32	25 bar	32*6	43-46	M6x20	
DC32X8AL*	Aluminum	32	25 bar	32*8	47-50	M6x20	
DC38X5AL*	Aluminum	38	25 bar	38*5	47-49	M6x20	
DC38X6,5AL	Aluminum	38	25 bar	38*6,5	50-53	M6x20	
DC38X8AL*	Aluminum	38	25 bar	38*8	53-56	M6x20	
DC38X10AL*	Aluminum	38	25 bar	38*10	57-60	M6x20	
DC40X7AL*	Aluminum	40	25 bar	40*7	53-56	M6x20	
DC40X10AL*	Aluminum	40	25 bar	40*10	58-61	M6x20	
DC45X7AL*	Aluminum	45	25 bar	45*7	58-61	M8x25	
DC50X2AL*	Aluminum	50	25 bar	50*2	54-56	M8x25	
DC50X5AL*	Aluminum	50	25 bar	50*5	59-61	M8x25	
DC50X6AL*	Aluminum	50	25 bar	50*6	61-63	M8x25	
DC50X8AL	Aluminum	50	25 bar	50*8	63-67	M8x25	
DC50X10AL*	Aluminum	50	25 bar	50*10	69-71	M8x25	
DC63X6AL*	Aluminum	63	25 bar	63*6	74-76	M8x25	
DC63X8AL	Aluminum	63	25 bar	63*8	78-82	M8x25	
DC63X10AL*	Aluminum	63	25 bar	63*10	84-87	M8x25	

NEW

Klemmschale nach EN 14420-3 - Schrauben aus Stahl

Safety clamp EN 14420-3 - Screws in steel

Collier demi-coquilles EN 14420-3 - Visserie Acier

Abrazadera de seguridad EN 14420-3 - Tornillos en acero

Obejmy skorupowe skręcane zgodnie EN 14420-3 - Śruby ze stali

Morsetto di sicurezza EN 14420-3 - Viti in acciaio



Part-No.	Material	DN	WP	Hose	Shank	Screw	Price
DC75X6AL	Aluminum	75	25 bar	75*6	85-89	M8x25	
DC75X8AL	Aluminum	75	25 bar	75*8	89-93	M8x25	
DC75X10AL*	Aluminum	75	25 bar	75*10	94-97	M8x25	
DC75X12AL*	Aluminum	75	25 bar	75*12	98-101	M8x25	
DC80X8AL*	Aluminum	80	25 bar	80*8	94-97	M8x25	
DC90X6,5AL	Aluminum	90	25 bar	90*6,5	101-105	M8x25	
DC100X6AL*	Aluminum	100	25 bar	100*6	111-115	M10x40	
DC100X8AL	Aluminum	100	25 bar	100*8	114-119	M10x40	
DC100X10AL*	Aluminum	100	25 bar	100*10	118-122	M10x40	
DC100X12AL*	Aluminum	100	25 bar	100*12	122-126	M10x40	
DC100x14AL*	Aluminum	100	25 bar	100*14	126-130	M10x40	
DC125X10AL	Aluminum	125	25 bar	125*10	143-148	M12x40	
DC150X10AL	Aluminum	150	16 bar	150*10	168-174	M12x60	
DC200X12AL	Aluminum	200	16 bar	200*12	222-229	M12x50	

*Sonderabmessungen
special size

Klemmschale nach EN 14420-3 - Schrauben aus Stahl

Safety clamp EN 14420-3 - screws in steel

Collier demi-coquilles EN 14420-3 - Visserie Acier

Abrazadera de seguridad EN 14420-3 - Tornillos en acero

Obejmy skorupowe skręcane zgodnie EN 14420-3 - Śruby ze stali

Morsetto di sicurezza EN 14420-3 - Viti in acciaio



Part-No.	Color	Material	DN	WP	Hose	Shank	Screw	Price
DC19X6ALB	Blue	Aluminum	19	25 bar	19*6	30-33	M6x20	
DC25X6ALB	Blue	Aluminum	25	25 bar	25*6	36-39	M6x20	
DC32X6ALB	Blue	Aluminum	32	25 bar	32*6	43-46	M6x20	
DC38X6,5ALB	Blue	Aluminum	38	25 bar	38*6,5	50-53	M6x20	
DC50X8ALB	Blue	Aluminum	50	25 bar	50*8	63-67	M8x25	
DC75X8ALB	Blue	Aluminum	75	25 bar	75*8	89-93	M8x25	
DC19X6ALR	Red	Aluminum	19	25 bar	19*6	30-33	M6x20	
DC25X6ALR	Red	Aluminum	25	25 bar	25*6	36-39	M6x20	
DC32X6ALR	Red	Aluminum	32	25 bar	32*6	43-46	M6x20	
DC38X6,5ALR	Red	Aluminum	38	25 bar	38*6,5	50-53	M6x20	
DC50X8ALR	Red	Aluminum	50	25 bar	50*8	63-67	M8x25	
DC75X8ALR	Red	Aluminum	75	25 bar	75*8	89-93	M8x25	
DC19X6ALS	Black	Aluminum	19	25 bar	19*6	30-33	M6x20	
DC25X6ALS	Black	Aluminum	25	25 bar	25*6	36-39	M6x20	
DC32X6ALS	Black	Aluminum	32	25 bar	32*6	43-46	M6x20	
DC38X6,5ALS	Black	Aluminum	38	25 bar	38*6,5	50-53	M6x20	
DC50X8ALS	Black	Aluminum	50	25 bar	50*8	63-67	M8x25	
DC75X8ALS	Black	Aluminum	75	25 bar	75*8	89-93	M8x25	

Klemmschale nach EN 14420-3 - Schrauben aus Stahl

Safety clamp EN 14420-3 - screws in steel

Collier demi-coquilles EN 14420-3 - Visserie Acier

Abrazadera de seguridad EN 14420-3 - Tornillos en acero

Obejmy skorupowe skręcane zgodnie EN 14420-3 - Śruby ze stali

Morsetto di sicurezza EN 14420-3 - Viti in acciaio

Part-No.	Color	Material	DN	WP	Hose	Shank	Screw	Price
DC19X6ALW	white	Aluminum	19	25 bar	19*6	30-33	M6x20	
DC25X6ALW	white	Aluminum	25	25 bar	25*6	36-39	M6x20	
DC32X6ALW	white	Aluminum	32	25 bar	32*6	43-46	M6x20	
DC38X6,5ALW	white	Aluminum	38	25 bar	38*6,5	50-53	M6x20	
DC50X8ALW	white	Aluminum	50	25 bar	50*8	63-67	M8x25	
DC75X8ALW	white	Aluminum	75	25 bar	75*8	89-93	M8x25	
DC19X6ALG	yellow	Aluminum	19	25 bar	19*6	30-33	M6x20	
DC25X6ALG	yellow	Aluminum	25	25 bar	25*6	36-39	M6x20	
DC32X6ALG	yellow	Aluminum	32	25 bar	32*6	43-46	M6x20	
DC38X6,5ALG	yellow	Aluminum	38	25 bar	38*6,5	50-53	M6x20	
DC50X8ALG	yellow	Aluminum	50	25 bar	50*8	63-67	M8x25	
DC75X8ALG	yellow	Aluminum	75	25 bar	75*8	89-93	M8x25	





Spannschale nach EN 14420-3

Safety clamp with pin EN 14420-3

Collier demi-coquilles EN 14420-3

Abrazadera de seguridad con clavija EN 14420-3

Obejmy skorupowe z bolcem zgodnie EN 14420-3

Morsetto di sicurezza EN 14420-3 - con perno

Part-No.	Material	DN	WP	Hose	Shank	Screw	Price
DC25X6ALSF	Aluminum	25	25 bar	25*6	34-36		
DC32X6ALSF	Aluminum	32	25 bar	32*6	40-43		
DC38X6,5ALSF	Aluminum	38	25 bar	38*6,5	50-53		
DC50X8ALSF	Aluminum	50	25 bar	50*8	63-67		
DC65X7ALSF	Aluminum	65	25 bar	65*7	78-82		
DC75X8ALSF	Aluminum	75	25 bar	75*8	89-93		
DC75X10ALSF	Aluminum	75	25 bar	75*10	94-97		
DC100X8ALSF	Aluminum	100	25 bar	100*8	114-118		

Klemmschale nach EN 14420-3 - Schrauben aus Edelstahl

Safety clamp EN 14420-3 - screws in stainless steel

Collier demi-coquilles EN 14420-3 - Visserie Inox

Abrazadera de seguridad EN 14420-3 - Tornillos en acero inoxidable

Obejmy skorupowe skręcane zgodnie EN 14420-3 - Śruby ze stali nierdzewnej

Morsetto di sicurezza EN 14420-3 - Viti in acciaio inossidabile



Part-No.	Material	DN	WP	Hose	Shank	Screw	Price
DC13X5SS	SS 316	13	25 bar	13*5	22-24	M6x20	
DC19X6SS	SS 316	19	25 bar	19*6	30-33	M6x20	
DC25X6SS	SS 316	25	25 bar	25*6	36-39	M6x20	
DC32X6SS	SS 316	32	25 bar	32*6	43-46	M6x20	
DC38X6,5SS	SS 316	38	25 bar	38*6,5	50-53	M6x20	
DC38X8SS*	SS 316	38	25 bar	38*8	53-56	M6x20	
DC50X6SS*	SS 316	50	25 bar	50*6	61-63	M8x25	
DC50X8SS	SS 316	50	25 bar	50*8	63-67	M8x25	
DC50X10SS*	SS 316	50	25 bar	50*10	69-71	M8x25	
DC63X8SS	SS 316	63	25 bar	63*8	78-82	M8x25	
DC75X8SS	SS 316	75	25 bar	75*8	89-93	M8x25	
DC80X8SS	SS 316	80	25 bar	80*8	94-97	M8x25	
DC100X8SS	SS 316	100	25 bar	100*8	114-119	M10x40	
DC100X10SS	SS 316	100	25 bar	100*10	118-122	M10x40	

*Sonderabmessungen
special size



Klemmschale nach EN 14420-3 - Schrauben aus Edelstahl

Safety clamp EN 14420-3 - screws in stainless steel

Collier demi-coquilles EN 14420-3 - Visserie Inox

Abrazadera de seguridad EN 14420-3 - Tornillos en acero inoxidable

Obejmy skorupowe skręcane zgodnie EN 14420-3 - Śruby ze stali nierdzewnej

Morsetto di sicurezza EN 14420-3 - Viti in acciaio inossidabile

Part-No.	Material	DN	WP	Hose	Shank	Screw	Price
DC13X5BR	Brass	13	25 bar	13*5	22-24	M6x20	
DC19X6BR	Brass	19	25 bar	19*6	30-33	M6x20	
DC25X6BR	Brass	25	25 bar	25*6	36-39	M6x20	
DC32X6BR	Brass	32	25 bar	32*6	43-46	M6x20	
DC38X6,5BR	Brass	38	25 bar	38*6,5	50-53	M6x20	
DC38X8BR*	Brass	38	25 bar	38*8	53-56	M6x20	
DC50X8BR	Brass	50	25 bar	50*8	63-67	M8x25	
DC63X8BR	Brass	63	25 bar	63*8	78-82	M8x25	
DC75X8BR	Brass	75	25 bar	75*8	89-93	M8x25	
DC100X8BR	Brass	100	25 bar	100*8	114-119	M10x40	

*Sonderabmessungen

special size

Klemmschale - Schrauben aus Edelstahl

Safety clamp - screws in stainless-steel

Collier demi-coquilles - Visserie Inox

Abrazadera de seguridad - Tornillos en acero inoxidable

Obejmy skorupowe skręcane zgodnie - Śruby ze stali nierdzewnej

Morsetto di sicurezza - Viti in acciaio inossidabile

Part-No.	Color	Material	DN	WP	Hose	Shank	Screw	Price
DC25X6PP	Black	Polypropylene	25	8bar	25*6	36-39	M6x20	
DC32X6PP	Black	Polypropylene	32	8bar	32*6	43-46	M6x20	
DC38X6,5PP	Black	Polypropylene	38	8bar	38*6,5	50-53	M6x20	
DC38X8PP	Black	Polypropylene	38	8bar	38*8	53-56	M6x20	
DC50X6PP	Black	Polypropylene	50	8bar	50*6	61-63	M8x25	
DC50X8PP	Black	Polypropylene	50	8bar	50*8	63-67	M8x25	
DC50X10PP	Black	Polypropylene	50	8bar	50*10	69-71	M8x25	
DC63X8PP	Black	Polypropylene	63	8bar	63*8	78-82	M8x25	
DC75X8PP	Black	Polypropylene	75	8bar	75*8	89-93	M8x25	
DC25X6PPW	White	Polypropylene	25	8bar	25*6	36-39	M6x20	
DC32X6PPW	White	Polypropylene	32	8bar	32*6	43-46	M6x20	
DC38X6,5PPW	White	Polypropylene	38	8bar	38*6,5	50-53	M6x20	
DC38X8PPW	White	Polypropylene	38	8bar	38*8	53-56	M6x20	
DC50X6PPW	White	Polypropylene	50	8bar	50*6	61-63	M8x25	
DC50X8PPW	White	Polypropylene	50	8bar	50*8	63-67	M8x25	
DC50X10PPW	White	Polypropylene	50	8bar	50*10	69-71	M8x25	
DC63X8PPW	White	Polypropylene	63	8bar	63*8	78-82	M8x25	
DC75X8PPW	White	Polypropylene	75	8bar	75*8	89-93	M8x25	



Klemmschale - Schrauben aus Edelstahl

Safety clamp - screws in stainless steel

Collier demi-coquilles - Visserie Inox

Abrazadera de seguridad - Tornillos en acero inoxidable

Obejmy skorupowe skręcane zgodnie - Śruby ze stali nierdzewnej

Morsetto di sicurezza - Viti in acciaio inossidabile



Part-No.	Color	Material	DN	WP	Hose	Shank	Screw	Price
DC25X6PPB	Blue	Polypropylene	25	8bar	25*6	36-39	M6x20	
DC32X6PPB	Blue	Polypropylene	32	8bar	32*6	43-46	M6x20	
DC38X6,5PPB	Blue	Polypropylene	38	8bar	38*6,5	50-53	M6x20	
DC38X8PPB	Blue	Polypropylene	38	8bar	38*8	53-56	M6x20	
DC50X6PPB	Blue	Polypropylene	50	8bar	50*6	61-63	M8x25	
DC50X8PPB	Blue	Polypropylene	50	8bar	50*8	63-67	M8x25	
DC50X10PPB	Blue	Polypropylene	50	8bar	50*10	69-71	M8x25	
DC63X8PPB	Blue	Polypropylene	63	8bar	63*8	78-82	M8x25	
DC75X8PPB	Blue	Polypropylene	75	8bar	75*8	89-93	M8x25	
DC25X6PPR	Red	Polypropylene	25	8bar	25*6	36-39	M6x20	
DC32X6PPR	Red	Polypropylene	32	8bar	32*6	43-46	M6x20	
DC38X6,5PPR	Red	Polypropylene	38	8bar	38*6,5	50-53	M6x20	
DC38X8PPR	Red	Polypropylene	38	8bar	38*8	53-56	M6x20	
DC50X6PPR	Red	Polypropylene	50	8bar	50*6	61-63	M8x25	
DC50X8PPR	Red	Polypropylene	50	8bar	50*8	63-67	M8x25	
DC50X10PPR	Red	Polypropylene	50	8bar	50*10	69-71	M8x25	
DC63X8PPR	Red	Polypropylene	63	8bar	63*8	78-82	M8x25	
DC75X8PPR	Red	Polypropylene	75	8bar	75*8	89-93	M8x25	

Schrauben und Muttern

Screws and nuts

Visserie et écrous

Schrauben und Muttern

Śruby i nakrętki

Viti e dadi

Part-No.	Description	Material	Screws	Dimension	Price
DCM6X20SS	Replacement screws	Stainless Steel	4	13-40	
DCM8X25SS	Replacement screws	Stainless Steel	4	45-90	
DCM10X40SS	Replacement screws	Stainless Steel	4	100	
DCM6X20AC	Replacement screws	Steel	4	13-40	
DCM8X25AC	Replacement screws	Steel	4	45-90	
DCM10X40AC	Replacement screws	Steel	4	100	
DCM12X60AC	Replacement screws	Steel	6	125-200	
M6X40AC	Assembly screws	Steel	4	13-40	
M8X50AC	Assembly screws	Steel	4	45-90	
M10X70AC	Assembly screws	Steel	4	100	
M12X80AC	Assembly screws	Steel	4	125-200	
M16X90AC	Assembly screws	Steel	4		
M6X40AC-FT	Assembly screws	Steel	1	13-40	
M8X50AC-FT	Assembly screws	Steel	1	45-90	
M10X70AC-FT	Assembly screws	Steel	1	100	
M12X80AC-FT	Assembly screws	Steel	1	125-200	
M6NUTAC-SL	Nut Self-Locking	Steel	1		
M8NUTAC-SL	Nut Self-Locking	Steel	1		
M10NUTAC-SL	Nut Self-Locking	Steel	1		
M10x30NUTAC	Nut	Steel	1		
M12x40NUTAC	Nut	Steel	1		

**NEW****NEW****NEW**



Edelstahlpresshülse mit Verzahnung - Edelstahl (SS 304)

- Cranted ferrule - stainless-steel (SS 304)
- Jupe crantée - Inox
- Campana interior dentado - Acero inoxidable (SS 304)
- Tuleja zaciskowa - Stal nierdzewna (SS 304)
- Boccola a pressare - Acciaio inossidabile (SS 304)

Part-No.	DN	Hose	WP	D	B	A	Length	Price
CF013X21	DN13	13x4	25 bar	28,50	22,50	19,30	42,00	
CF013X23	DN13	13x5	25 bar	30,50	24,50	19,30	42,00	
CF013X25	DN13	13x6	25 bar	32,50	26,50	19,30	42,00	
CF019X27	DN19	19x4	25 bar	34,50	28,50	26,30	42,00	
CF019X29	DN19	19x5	25 bar	37,00	31,00	26,30	42,00	
CF019X31	DN19	19x6	25 bar	39,00	33,00	26,30	42,00	
CF025X35	DN25	25x5	25 bar	43,00	37,00	32,50	42,00	
CF025X37	DN25	25x6	25 bar	45,00	39,00	32,50	42,00	
CF025X41	DN25	25x8	25 bar	49,00	43,00	32,50	42,00	
CF032X42	DN32	32x5	25 bar	50,00	44,00	39,50	42,00	
CF032X44	DN32	32x6	25 bar	52,00	46,00	39,50	42,00	
CF032X46	DN32	32x7	25 bar	54,00	48,00	39,50	42,00	
CF038X48	DN38	38x5	25 bar	56,00	50,00	45,50	42,00	
CF038X50	DN38	38x6	25 bar	58,00	52,00	45,50	42,00	
CF038X54	DN38	38x8	25 bar	62,00	56,00	45,50	42,00	
CF038X56	DN38	38x9	25 bar	64,00	58,00	45,50	42,00	
CF040X52	DN40	40x6	25 bar	60,00	54,00	45,50	42,00	
CF040X60	DN40	40x10	25 bar	68,00	62,00	45,50	42,00	
CF050X61	DN50	50x5.5	25 bar	70,00	63,00	58,50	49,00	
CF050X62	DN50	50x6	25 bar	71,00	64,00	58,50	49,00	
CF050X64	DN50	50x7	25 bar	73,00	66,00	58,50	49,00	
CF050X66	DN50	50x8	25 bar	75,00	68,00	58,50	49,00	
CF050X70	DN50	50x10	25 bar	79,00	72,00	58,50	49,00	
CF050X72	DN50	50x11	25 bar	81,00	74,00	58,50	49,00	
CF050X74	DN50	50x12	25 bar	83,00	76,00	58,50	49,00	

Edelstahlpresshülse mit Verzahnung - Edelstahl (SS 304)

Cranted ferrule -stainless-steel (SS 304)

Jupe crantée - Inox

Campana interior dentado - Acero inoxidable (SS 304)

Tuleja zaciskowa - Stal nierdzewna (SS 304)

Boccola a pressare - Acciaio inossidabile (SS 304)



Part-No.	DN	Hose	WP	D	B	A	Length	Price
CF065X75	DN65	65x5	25 bar	84,50	77,50	73,50	63,00	
CF065X77	DN65	65x6	25 bar	86,50	79,50	73,50	63,00	
CF065X79	DN65	65x7	25 bar	88,50	81,50	73,50	63,00	
CF065X89	DN65	65x12	25 bar	99,00	92,00	73,50	63,00	
CF065X91	DN65	65x13	25 bar	103,00	96,00	73,50	63,00	
CF070x84	DN70	70x7	25 bar	93,00	86,00	73,50	63,00	
CF075X87	DN75	75x6	25 bar	96,50	89,50	85,50	67,00	
CF075X91	DN75	75x8	25 bar	100,50	93,50	85,50	67,00	
CF075X95	DN75	75x10	25 bar	104,50	97,50	85,50	67,00	
CF075X99	DN75	75x12	25 bar	110,00	102,00	85,50	67,00	
CF075X105	DN75	75x15	25 bar	116,00	108,00	85,50	67,00	
CF100X112	DN100	100x6	16 bar	123,00	115,00	111,00	96,00	
CF100X116	DN100	100x8	16 bar	127,00	119,00	111,00	96,00	
CF100X120	DN100	100x10	16 bar	131,00	123,00	111,00	96,00	
CF100X124	DN100	100x12	16 bar	136,00	127,00	111,00	96,00	
CF100X130	DN100	100x15	16 bar	143,00	133,00	111,00	96,00	

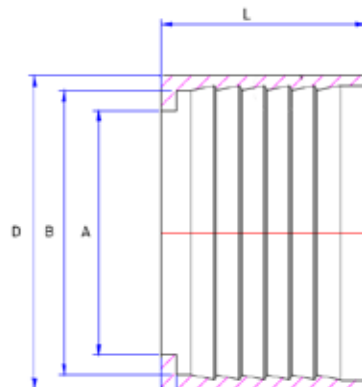



Edelstahlpresshülse mit Verzahnung - Lange Version - Edelstahl (SS 304)

Cranted ferrule - long version - stainless-steel (SS 304)

Jupe crantée - version longue- Inox

Campana interior dentado - VERSIÓN LARGa - Acero inoxidable (SS 304)

Tuleja zaciskowa - Werja dluga - Stal nierdzewna (SS 304)

Boccola a pressare - Versione lunga - Acciaio inossidabile (SS 304)

Part-No.	DN	Hose	WP	D	B	A	Length	Price
CF013X21-L	DN13	13x4	25 bar	28,50	22,50	19,30	50,00	
CF013X23-L	DN13	13x5	25 bar	30,50	24,50	19,30	50,00	
CF013X25-L	DN13	13x6	25 bar	32,50	26,50	19,30	50,00	
CF019X27-L	DN19	19x4	25 bar	34,50	28,50	26,30	50,00	
CF019X29-L	DN19	19x5	25 bar	37,00	31,00	26,30	50,00	
CF019X31-L	DN19	19x6	25 bar	39,00	33,00	26,30	50,00	
CF025X35-L	DN25	25x5	25 bar	43,00	37,00	32,50	50,00	
CF025X37-L	DN25	25x6	25 bar	45,00	39,00	32,50	50,00	
CF025X41-L	DN25	25x8	25 bar	49,00	43,00	32,50	50,00	
CF032X42-L	DN32	32x5	25 bar	50,00	44,00	39,50	50,00	
CF032X44-L	DN32	32x6	25 bar	52,00	46,00	39,50	50,00	
CF032X46-L	DN32	32x7	25 bar	54,00	48,00	39,50	50,00	
CF038X48-L	DN38	38x5	25 bar	56,00	50,00	45,50	50,00	
CF038X50-L	DN38	38x6	25 bar	58,00	52,00	45,50	50,00	
CF038X54-L	DN38	38x8	25 bar	62,00	56,00	45,50	50,00	
CF038X56-L	DN38	38x9	25 bar	64,00	58,00	45,50	50,00	
CF040X52-L	DN40	40x6	25 bar	60,00	54,00	45,50	50,00	
CF040X60-L	DN40	40x10	25 bar	68,00	62,00	45,50	50,00	
CF050X61-L	DN50	50x5,5	25 bar	70,00	63,00	58,50	56,00	
CF050X62-L	DN50	50x6	25 bar	71,00	64,00	58,50	56,00	
CF050X64-L	DN50	50x7	25 bar	73,00	66,00	58,50	56,00	
CF050X66-L	DN50	50x8	25 bar	75,00	68,00	58,50	56,00	
CF050X70-L	DN50	50x10	25 bar	79,00	72,00	58,50	56,00	
CF050X72-L	DN50	50x11	25 bar	81,00	74,00	58,50	56,00	
CF050X74-L	DN50	50x12	25 bar	83,00	76,00	58,50	56,00	

Edelstahlpresshülse mit Verzahnung - Lange Version - Edelstahl (SS 304)

Cranted ferrule - long version - stainless-steel (SS 304)

Jupe crantée - version longue- Inox

Campana interior dentado - VERSIÓN LARGa - Acero inoxidable (SS 304)

Tuleja zaciskowa - Werja dluga - Stal nierdzewna (SS 304)

Boccola a pressare - Versione lunga - Acciaio inossidabile (SS 304)



Part-No.	DN	Hose	WP	D	B	A	Length	Price
CF065X75-L	DN65	65x5	25 bar	84,50	77,50	73,50	74,00	
CF065X77-L	DN65	65x6	25 bar	86,50	79,50	73,50	74,00	
CF065X79-L	DN65	65x7	25 bar	88,50	81,50	73,50	74,00	
CF065X89-L	DN65	65x12	25 bar	99,00	92,00	73,50	74,00	
CF065X91-L	DN65	65x13	25 bar	103,00	96,00	73,50	74,00	
CF070X84-L	DN70	70x7	25 bar	93,00	86,00	73,50	74,00	
CF075X87-L	DN75	75x6	25 bar	96,50	89,50	85,50	76,00	
CF075X91-L	DN75	75x8	25 bar	100,50	93,50	85,50	76,00	
CF075X95-L	DN75	75x10	25 bar	104,50	97,50	85,50	76,00	
CF075X99-L	DN75	75x12	25 bar	110,00	102,00	85,50	76,00	
CF075X105-L	DN75	75x15	25 bar	116,00	108,00	85,50	76,00	
CF100X112-L	DN100	100x6	16 bar	123,00	115,00	111,00	120,00	
CF100X116-L	DN100	100x8	16 bar	127,00	119,00	111,00	120,00	
CF100X120-L	DN100	100x10	16 bar	131,00	123,00	111,00	120,00	
CF100X124-L	DN100	100x12	16 bar	136,00	127,00	111,00	120,00	

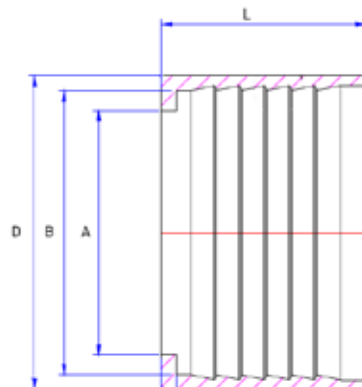



Stahlpresshülse mit Verzahnung - Stahl

Cranted ferrule - steel
 Jupe crantée - Acier
 Campana interior dentado - Acero
 Tuleja zaciskowa - Stal
 Boccola a pressare - Acciaio

PRESSHÜLSE

Part-No.	DN	Hose	WP	D	B	A	Length	Price
CF013X21AC	DN13	13x4	25 bar	28,50	22,50	19,30	42,00	
CF013X23AC	DN13	13x5	25 bar	30,50	24,50	19,30	42,00	
CF013X25AC	DN13	13x6	25 bar	32,50	26,50	19,30	42,00	
CF019X27AC	DN19	19x4	25 bar	34,50	28,50	26,30	42,00	
CF019X29AC	DN19	19x5	25 bar	37,00	31,00	26,30	42,00	
CF019X31AC	DN19	19x6	25 bar	39,00	33,00	26,30	42,00	
CF025X35AC	DN25	25x5	25 bar	43,00	37,00	32,50	42,00	
CF025X37AC	DN25	25x6	25 bar	45,00	39,00	32,50	42,00	
CF025X41AC	DN25	25x8	25 bar	49,00	43,00	32,50	42,00	
CF032X42AC	DN32	32x5	25 bar	50,00	44,00	39,50	42,00	
CF032X44AC	DN32	32x6	25 bar	52,00	46,00	39,50	42,00	
CF032X46AC	DN32	32x7	25 bar	54,00	48,00	39,50	42,00	
CF038X48AC	DN38	38x5	25 bar	56,00	50,00	45,50	42,00	
CF038X50AC	DN38	38x6	25 bar	58,00	52,00	45,50	42,00	
CF038X54AC	DN38	38x8	25 bar	62,00	56,00	45,50	42,00	
CF038X56AC	DN38	38x9	25 bar	64,00	58,00	45,50	42,00	
CF040X52AC	DN40	40x6	25 bar	60,00	54,00	45,50	42,00	
CF040X60AC	DN40	40x10	25 bar	68,00	62,00	45,50	42,00	
CF050X61AC	DN50	50x5.5	25 bar	70,00	63,00	58,50	49,00	
CF050X62AC	DN50	50x6	25 bar	71,00	64,00	58,50	49,00	
CF050X64AC	DN50	50x7	25 bar	73,00	66,00	58,50	49,00	
CF050X66AC	DN50	50x8	25 bar	75,00	68,00	58,50	49,00	
CF050X70AC	DN50	50x10	25 bar	79,00	72,00	58,50	49,00	
CF050X72AC	DN50	50x11	25 bar	81,00	74,00	58,50	49,00	
CF050X74AC	DN50	50x12	25 bar	83,00	76,00	58,50	49,00	

Stahlpresshülse mit Verzahnung - Stahl

Cranted ferrule - steel

Jupe crantée - Acier

Campana interior dentado - Acero

Tuleja zaciskowa - Stal

Boccola a pressare - Acciaio



PRESSHÜLSE

Part-No.	DN	Hose	WP	D	B	A	Length	Price
CF065X75AC	DN65	65x5	25 bar	84,50	77,50	73,50	63,00	
CF065X77AC	DN65	65x6	25 bar	86,50	79,50	73,50	63,00	
CF065X79AC	DN65	65x7	25 bar	88,50	81,50	73,50	63,00	
CF065X89AC	DN65	65x12	25 bar	99,00	92,00	73,50	63,00	
CF065X91AC	DN65	65x13	25 bar	103,00	96,00	73,50	63,00	
CF075X87AC	DN75	75x6	25 bar	96,50	89,50	85,50	67,00	
CF075X91AC	DN75	75x8	25 bar	100,50	93,50	85,50	67,00	
CF075X95AC	DN75	75x10	25 bar	104,50	97,50	85,50	67,00	
CF075X99AC	DN75	75x12	25 bar	110,00	102,00	85,50	67,00	
CF075X105AC	DN75	75x15	25 bar	116,00	108,00	85,50	67,00	
CF100X112AC	DN100	100x6	16 bar	123,00	115,00	111,00	96,00	
CF100X116AC	DN100	100x8	16 bar	127,00	119,00	111,00	96,00	
CF100X120AC	DN100	100x10	16 bar	131,00	123,00	111,00	96,00	
CF100X124AC	DN100	100x12	16 bar	136,00	127,00	111,00	96,00	
CF100X130AC	DN100	100x15	16 bar	143,00	133,00	111,00	96,00	

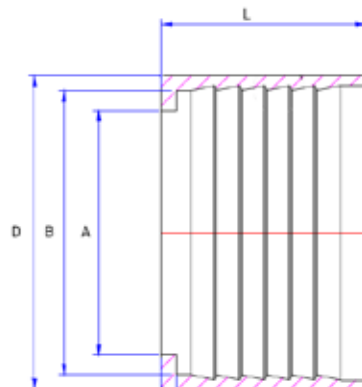



Edelstahlpresshülse mit Verzahnung - Edelstahl (SS 304)

Cranted ferrule - stainless-steel (SS 304)

Jupe crantée - Inox (SS 304)

Campana para recuperar racor - Acero inoxidable (SS 304)

Tuleja zaciskowa - Stal nierdzewna (SS 304)

Boccola a pressare con opzione di recupero di raccordo - Acciaio inossidabile (SS 304)

Part-No.	DN	Hose	WP	D	B	A	Length	Price
CFR013X21	DN13	13x4	25 bar	28,50	22,50	19,30	42,00	
CFR013X23	DN13	13x5	25 bar	30,50	24,50	19,30	42,00	
CFR019X29	DN19	19x5	25 bar	37,00	31,00	26,30	42,00	
CFR019X31	DN19	19x6	25 bar	39,00	33,00	26,30	42,00	
CFR025X35	DN25	25x5	25 bar	43,00	37,00	32,50	42,00	
CFR025X37	DN25	25x6	25 bar	45,00	39,00	32,50	42,00	
CFR025X41	DN25	25x8	25 bar	49,00	43,00	32,50	42,00	
CFR032X44	DN32	32x6	25 bar	52,00	46,00	39,50	42,00	
CFR032X46	DN32	32x7	25 bar	54,00	48,00	39,50	42,00	
CFR038X50	DN38	38x6	25 bar	58,00	52,00	45,50	42,00	
CFR038X54	DN38	38x8	25 bar	62,00	56,00	45,50	42,00	
CFR038X56	DN38	38x9	25 bar	64,00	58,00	45,50	42,00	
CFR040X60	DN40	40x10	25 bar	68,00	62,00	45,50	42,00	
CFR050X61	DN50	50x5.5	25 bar	70,00	63,00	58,50	49,00	
CFR050X62	DN50	50x6	25 bar	71,00	64,00	58,50	49,00	
CFR050X64	DN50	50x7	25 bar			58,50	49,00	
CFR050X66	DN50	50x8	25 bar	75,00	68,00	58,50	49,00	
CFR050X70	DN50	50x10	25 bar	79,00	72,00	58,50	49,00	
CFR065X79	DN65	65x7	25 bar	88,50	81,50	73,50	63,00	
CFR075X91	DN75	75x8	25 bar	100,50	93,50	85,50	67,00	

Vorteile dieser Presshülse:

Dieses spezielle Design ermöglicht durch einfaches Spalten/Trennen der Presshülse die Wiederverwendung der Schalenverschraubung

Advantage of this ferrule:

The special design allows to simplify the reuse of the hose shank by separating the crimping ferrule



Alupresshülse mit Verzahnung - Aluminium

Cranted ferrule - aluminum

Jupe crantée - Aluminium

Campana interior dentado - Aluminio

Tuleja zaciskowa - Aluminium

Boccola a pressare - Alluminio



PRESSHÜLSE

Part-No.	DN	Hose	WP	D	B	A	Length	Price
CF013X23AL	DN13	13x5	25 bar	30,50	24,50	19,30	42,00	
CF019X31AL	DN19	19x6	25 bar	39,00	33,00	26,30	42,00	
CF025X37AL	DN25	25x6	25 bar	45,00	39,00	32,50	42,00	
CF032X44AL	DN32	32x6	25 bar	52,00	46,00	39,50	42,00	
CF038X50AL	DN38	38x6	25 bar	58,00	52,00	45,50	42,00	
CF050X66AL	DN50	50x8	25 bar	75,00	68,00	58,50	49,00	
CF075X91AL	DN75	75x8	25 bar	100,50	93,50	85,50	67,00	

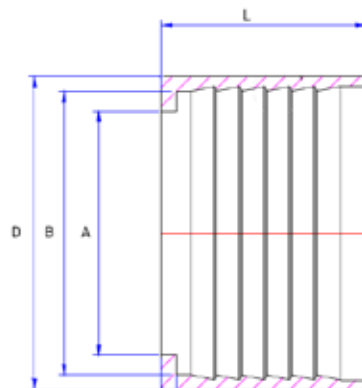

Rohr-Hülse zur Verpressung

Pipe ferrule for welding hose

Bague de sertissage

Campana para soldar

Tuleja do zaprasowania

Boccola a saldare



Part-No.	Material	WP	Size	Int*DP*Lg	Price
BAOND14	SS 304	4 bar	1/4"	12,8 * 1,5 * 20	
BAOND58	SS 304	4 bar	5/8"	25 * 1,5 * 20	
BAOND38	SS 304	4 bar	3/8"	17 * 1,5 * 20	
BAOND12	SS 304	4 bar	1/2"	20,5 * 1,5 * 20	
BAOND34	SS 304	4 bar	3/4"	26,5 * 1,5 * 25	
BAOND1	SS 304	4 bar	1"	37 * 2 * 25	
BAOND114	SS 304	4 bar	1 1/4"	40,5 * 2 * 30	
BAOND112	SS 304	4 bar	1 1/2"	50,5 * 2 * 30	
BAOND2	SS 304	4 bar	2"	68 * 2 * 35	
BAOND212	SS 304	4 bar	2 1/2"	87 * 2 * 35	
BAOND3	SS 304	4 bar	3"	98,5 * 2 * 40	
BAOND4	SS 304	4 bar	4"	121 * 2 * 50	
BA20AL	Aluminum	4 bar	DN20	26 * 2 * 30	
BA25AL	Aluminum	4 bar	DN25	31 * 2 * 30	
BA26AL	Aluminum	4 bar	DN25	36 * 2 * 30	
BA40AL	Aluminum	4 bar	DN40	46 * 2 * 30	
BA45AL	Aluminum	4 bar	DN45	51 * 2 * 30	
BA50AL	Aluminum	4 bar	DN50	57 * 2 * 30	
BA55AL	Aluminum	4 bar	DN55	67 * 2 * 30	
BA70AL	Aluminum	4 bar	DN70	76 * 2 * 40	
BA65AL	Aluminum	4 bar	DN65	84 * 2 * 30	
BA90AL	Aluminum	4 bar	DN90	101 * 2 * 65	
BA100AL	Aluminum	4 bar	DN100	102 * 2,5 * 90	
BA120AL	Aluminum	4 bar	DN120	120 * 2,5 * 90	

Presshülse gebördelt

Stamped ferrule

Jupe emboutie

Campana

Tuleja zaciskowa

Boccola a pressare

Part-No.	Material	WP	Size	Int*DP*Lg	Price
SSE1F	SS 304	6 bar	DN25	42 * 42 * 27.5	
SSE125F	SS 304	6 bar	DN32	50 * 45 * 36	
SSE150F	SS 304	6 bar	DN38	57 * 52 * 43.5	
SSE2F	SS 304	6 bar	DN50	67 * 63 * 55	
SSE250F	SS 304	6 bar	DN65	83 * 73 * 68	
SSE3F	SS 304	6 bar	DN80	98.5 * 75 * 83	
SSE4F	SS 304	6 bar	DN100	122.5 * 87 * 107	
ASE1F	Aluminum	6 bar	DN25	41 * 44 * 27	
ASE125F	Aluminum	6 bar	DN32	50 * 45 * 36	
ASE150F	Aluminum	6 bar	DN38	56 * 52 * 43.5	
ASE150F2	Aluminum	6 bar	DN38	61 * 52 * 46	
ASE2F	Aluminum	6 bar	DN50	67 * 63 * 55	
ASE2F1	Aluminum	6 bar	DN50	74 * 63 * 55	
ASE2F2	Aluminum	6 bar	DN50	50 * 60 * 45	
ASE2F3	Aluminum	6 bar	DN50	71 * 63 * 59	
ASE2F4	Aluminum	6 bar	DN50	60 * 45 * 52	
ASE2F5	Aluminum	6 bar	DN50	64 * 60 * 45	
ASE250F	Aluminum	6 bar	DN65	84 * 73 * 68	
ASE250F2	Aluminum	6 bar	DN65	89 * 55 * 71	
ASE275F	Aluminum	6 bar	DN75	92 * 75 * 76	
ASE3F	Aluminum	6 bar	DN80	101 * 75 * 83.5	
ASE3FA	Aluminum	6 bar	DN80	98,5 * 75 * 84	
ASE3F2	Aluminum	6 bar	DN80	102 * 75 * 87	
ASE3FSPE	Aluminum	6 bar	DN80	100 * 74 * 91	
ASE3FVRAC	Aluminum	6 bar	DN80	102 * 74 * 91	
ASE4F	Aluminum	6 bar	DN100	122.5 * 87 * 107	
ASE4F2	Aluminum	6 bar	DN100	126 * 87 * 107	
ASE4F3	Aluminum	6 bar	DN100	130 * 87 * 111	
ASE4FVRAC	Aluminum	6 bar	DN100	124 * 87 * 111	

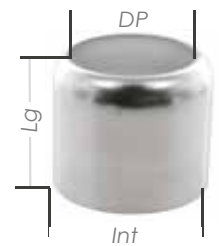



High Torque Schlauchschellen

High torque

Colliers de serrage pour tuyaux flexibles à couple élevé

Abrazaderas cremallera para tubos flexibles de HI - TORQUE

High Torque Opaska

Morsetto di securità per tubi flessibile HI- TORQUE

Part-No.	Material	Size	Price
HT035	SS 304	20-35	
HT040	SS 304	25-40	
HT045	SS 304	25-45	
HT050	SS 304	30-50	
HT070	SS 304	40-70	
HT080	SS 304	60-80	
HT095	SS 304	70-95	
HT100	SS 304	80-100	
HT120	SS 304	90-120	
HT140	SS 304	110-140	
HT160	SS 304	130-160	
HT180	SS 304	150-180	
HT200	SS 304	170-200	
HT220	SS 304	190-220	
HT240	SS 304	210-240	
HT260	SS 304	230-260	
HT280	SS 304	250-280	
HT300	SS 304	270-300	
HT320	SS 304	290-320	
HT340	SS 304	310-340	
HT360	SS 304	330-360	
HT380	SS 304	350-380	
HT400	SS 304	370-400	
HT420	SS 304	390-420	
HT440	SS 304	410-440	
HT460	SS 304	430-460	
HT480	SS 304	450-480	
HT500	SS 304	470-500	

Standard-Schlauchschellen

Standard range

Colliers de serrage standard

Abrazaderas estándar

Standard Opaska

Morsetti standard



Size	Width	Part-No	Material	Price	Part-No	Material	Price	Part-No	Material	Price	Size	Size
9,5-12	9	000MS	Steel W1		000SS	W4 304		000SS316	W5 316		9,5-12	9
11-16	9	M00MS	Steel W1		M00SS	W4 304		M00SS316	W5 316		11-16	9
13-20	9	00MS	Steel W1		00SS	W4 304		00SS316	W5 316		13-20	9
16-22	13	0MS	Steel W1		0SS	W4 304		0SS316	W5 316		16-22	13
18-25	13	0XMS	Steel W1		0XSS	W4 304		0XSS316	W5 316		18-25	13
22-30	13	1AMS	Steel W1		1ASS	W4 304		1ASS316	W5 316		22-30	13
25-35	13	1MS	Steel W1		1SS	W4 304		1SS316	W5 316		25-35	13
30-40	13	1XMS	Steel W1		1XSS	W4 304		1XSS316	W5 316		30-40	13
32-45	13	1MMS	Steel W1		1MSS	W4 304		1MSS316	W5 316		32-45	13
35-50	13	2AMS	Steel W1		2ASS	W4 304		2ASS316	W5 316		35-50	13
40-55	13	2MS	Steel W1		2SS	W4 304		2SS316	W5 316		40-55	13
45-60	13	2XMS	Steel W1		2XSS	W4 304		2XSS316	W5 316		45-60	13
55-70	13	3MS	Steel W1		3SS	W4 304		3SS316	W5 316		55-70	13
60-80	13	3XMS	Steel W1		3XSS	W4 304		3XSS316	W5 316		60-80	13
70-90	13	4MS	Steel W1		4SS	W4 304		4SS316	W5 316		70-90	13
85-100	13	4XMS	Steel W1		4XSS	W4 304		4XSS316	W5 316		85-100	13
90-120	13	5MS	Steel W1		5SS	W4 304		5SS316	W5 316		90-120	13
110-140	13	6MS	Steel W1		6SS	W4 304		6SS316	W5 316		110-140	13
120-150	13	6XMS	Steel W1		6XSS	W4 304		6XSS316	W5 316		120-150	13
135-165	13	7MS	Steel W1		7SS	W4 304		7SS316	W5 316		135-165	13
158-190	13	7.5MS	Steel W1		7.5SS	W4 304		7.5SS316	W5 316		158-190	13
184-216	13	8.5MS	Steel W1		8.5SS	W4 304		8.5SS316	W5 316		184-216	13
210-242	13	9.5MS	Steel W1		9.5SS	W4 304		9.5SS316	W5 316		210-242	13
235-267	13	10.5MS	Steel W1		10.5SS	W4 304		10.5SS316	W5 316		235-267	13
260-292	13	11.5MS	Steel W1		11.5SS	W4 304		11.5SS316	W5 316		260-292	13
286-318	13	12.5MS	Steel W1		12.5SS	W4 304		12.5SS316	W5 316		286-318	13



2-Ohr Schellen

2-Ear clamp

Pinces à deux oreilles

Abrazaderas con dos orejas

Jednoczęściowy pierścień zaciskowy EAR CLIP z 2 uszami

Morsetti con due orecchie

Part-No.	Material	Size	Price
2EAR3-5	Steel W1	3-5	
2EAR5-7	Steel W1	5-7	
2EAR7-9	Steel W1	7-9	
2EAR9-11	Steel W1	9-11	
2EAR11-13	Steel W1	11-13	
2EAR13-15	Steel W1	13-15	
2EAR14-17	Steel W1	14-17	
2EAR15-18	Steel W1	15-18	
2EAR17-20	Steel W1	17-20	
2EAR18-21	Steel W1	18-21	
2EAR20-23	Steel W1	20-23	
2EAR21-25	Steel W1	21-25	
2EAR23-27	Steel W1	23-27	
2EAR25-28	Steel W1	25-28	
2EAR28-31	Steel W1	28-31	
2EAR31-34	Steel W1	31-34	
2EAR34-37	Steel W1	34-37	
2EAR37-40	Steel W1	37-40	
2EAR40-43	Steel W1	40-43	
2EAR43-46	Steel W1	43-46	

Schlauchklemme 2-teilig, mit losen Zungen und Sicherungsklauen nach DIN20039

Heavy duty double bolts clamp with safety claws acc. DIN 20039

Collier de serrage 2 boulons - Norme DIN20039

Abrazadera con garras de seguridad DIN 20039

Obejmy dwuczęściowe, z osobnymi wkładkami - «językami» dociskowymi i z zaczepami («pazurami») na kołnierz zabezpieczający końcówki zgodnie DIN20039

Morsetto di sicurezza DIN20039



Part-No.	Material	WP	Dimension	Size	Price
SK29	galvanized Steel	10 bar	13	22-29	
SK34	galvanized Steel	10 bar	19	27-34	
SK39	galvanized Steel	10 bar	25	32-39	
SK51	galvanized Steel	10 bar	35	39-49	
SK60	galvanized Steel	10 bar	42	48-60	



* ohne
* without



Schlauchklemme 2-teilig, mit losen Zungen nach DIN20039

Heavy duty double bolt clamp acc. DIN 20039

Collier 2 boulons avec languette libre - Norme DIN20039

Abrazadera media luna de seguridad DIN 20039

Obejmy dwuczęściowe, z osobnymi wkładkami - «językami» dociskowymi zgodnie DIN20039

Morsetto di sicurezza in due pezzi DIN20039 - DIN20039

Part-No.	Material	WP	Size	Price
SL22*	galvanized Steel	10 bar	17-22	
SL29*	galvanized Steel	10 bar	22-29	
SL34*	galvanized Steel	10 bar	27-34	
SL40*	galvanized Steel	10 bar	40-40	
SL49*	galvanized Steel	10 bar	40-49	
SL60	galvanized Steel	10 bar	48-60	
SL76	galvanized Steel	10 bar	60-76	
SL94	galvanized Steel	10 bar	77-94	
SL115	galvanized Steel	10 bar	94-115	
SL525	galvanized Steel	10 bar	103-125	
SL600	galvanized Steel	10 bar	130-144	
SL769	galvanized Steel	10 bar	165-192	
SL875	galvanized Steel	10 bar	210-225	
SL988	galvanized Steel	10 bar	227-239	
SL1125	galvanized Steel	10 bar	252-298	
SL1275	galvanized Steel	10 bar	300-330	
SL1450	galvanized Steel	10 bar	335-381	

MCC Band mit Kunststoffverpackung oder Karton

MCC Band with plastic packaging or carton

Ruban MCC avec emballage plastique ou boîte en carton

Cinta MCC con embalaje de plástico o caja de cartón

MCC Taśma (w kartonie / lub z plastikowym opakowaniem)

Nastro MCC con confezione in plastica o scatola di cartone



Part-No.	Material	Box	Length	Width	Thickness	Price
MC202	SS 201	Carton	30,4 m	6,4 mm	0,51 mm	
MC203	SS 201	Carton	30,4 m	9,6 mm	0,64 mm	
MC203Y	SS 201	Yellow - plastic	30,4 m	9,6 mm	0,64 mm	
MC204	SS 201	Carton	30,4 m	12,7 mm	0,76 mm	
MC204B	SS 201	Blue - plastic	30,4 m	12,7 mm	0,76 mm	
MC205G	SS 201	Green - plastic	30,4 m	15,9 mm	0,76 mm	
MC206R	SS 201	Red - plastic	30,4 m	19,1 mm	0,76 mm	

Box mit 100 Stk. Schlaufen MCC Clips (einfache Beanspruchung)

Box with 100 pcs buckle MCC clips

Boîte avec 100 pièces Boucle Clip MCC

Pack 100 unidades hebillas para fleje

Boks z 100 szt. MCC Zapinki (dla prostego obciążenia)

Confezione da 100 pezzi con clip di fissaggio MCC



Part-No.	Material	Buckle/Box	for Band Width	Price
MC252	SS 201	100 pcs	6,4 mm	
MC154	SS 201	100 pcs	12,7 mm	
MC155	SS 201	100 pcs	15,9 mm	
MC156	SS 201	100 pcs	19,1 mm	



Box mit 100 Stk. Schlaufen MCC Clips (hohe Beanspruchung)

Box with 100 pcs buckle MCC clips

Boîte avec 100 pièces Boucle Clip MCC

Pack 100 unidades hebillas para fleje

Boks z 100 szt. MCC Zapinki (dla dużego obciążenia)

Confezione da 100 pezzi con clip di fissaggio MCC

Part-No.	Material	Buckle/Box	for Band Width	Price
MC253	SS 201	100 pcs	9,6 mm	
MC254	SS 201	100 pcs	12,7 mm	
MC255	SS 201	100 pcs	15,9 mm	
MC256	SS 201	100 pcs	19,1 mm	
MC453	SS 316	100 pcs	9,6 mm	
MC454	SS 316	100 pcs	12,7 mm	
MC455	SS 316	100 pcs	15,9 mm	
MC456	SS 316	100 pcs	19,1 mm	

MCC Band

MCC band
 Bande MCC
 MCC Fleje
 MCC Taśma
 Nastro MCC



Part-No.	Material	Box	Length	Width	Thikness	Price
MC133	SS 300	Carton	30,4 m	9,6 mm	0,38 mm	
MC134	SS 300	Carton	30,4 m	12,7 mm	0,38 mm	
MC128	SS 300	Carton	60,8 m	12,7 mm	0,38 mm	
MC135	SS 300	Carton	30,4 m	15,9 mm	0,38 mm	
MC136	SS 300	Carton	30,4 m	19,1 mm	0,38 mm	
MC403	SS 316	Carton	30,4 m	9,6 mm	0,64 mm	
MC404	SS 316	Carton	30,4 m	12,7 mm	0,76 mm	
MC405	SS 316	Carton	30,4 m	15,9 mm	0,76 mm	
MC406	SS 316	Carton	30,4 m	19,1 mm	0,76 mm	
MG430	SS 201	Carton	30,4 m	19,1 mm	1,10 mm	
MG431	SS 201	Carton	30,4 m	25,4 mm	1,10 mm	
MG432	SS 201	Carton	30,4 m	31,8 mm	1,10 mm	



Vorgefertigte MCC Schelle - J-Serie

Preformed MCC clamp - J-serie
 Collier de serrage préfabriqué MCC - J-Serie
 Abrazadera preformada MCC - J-Serie
 Preformowane MCC Opaski zaciskowe - Seria J
 Morsetto preformato MCC - J-Serie

Part-No.	Material	Band	ID	Width	Price
MJS227	SS 201	3/4"	50 mm	19,1 mm	
MJS210	SS 201	3/4"	69 mm	19,1 mm	
MJS211	SS 201	3/4"	76 mm	19,1 mm	
MJS212	SS 201	3/4"	88 mm	19,1 mm	
MJS213	SS 201	3/4"	101 mm	19,1 mm	
MJS214	SS 201	3/4"	114 mm	19,1 mm	
MJS215	SS 201	3/4"	127 mm	19,1 mm	
MJS216	SS 201	3/4"	152 mm	19,1 mm	
MJS218	SS 201	3/4"	177 mm	19,1 mm	
MJS219	SS 201	3/4"	203 mm	19,1 mm	
MJS205	SS 201	5/8"	38 mm	15,9 mm	
MJS206	SS 201	5/8"	44 mm	15,9 mm	
MJS207	SS 201	5/8"	50 mm	15,9 mm	
MJS208	SS 201	5/8"	57 mm	15,9 mm	
MJS209	SS 201	5/8"	63 mm	15,9 mm	
MJS203	SS 201	1/2"	25 mm	12,7 mm	
MJS204	SS 201	1/2"	31 mm	12,7 mm	
MJS231	SS 201	1/2"	38 mm	12,7 mm	
MJS236	SS 201	1/2"	44 mm	12,7 mm	
MJS237	SS 201	1/2"	50 mm	12,7 mm	
MJS230	SS 201	1/2"	69 mm	12,7 mm	
MJS247	SS 201	1/2"	88 mm	12,7 mm	
MJS249	SS 201	1/2"	101 mm	12,7 mm	

Vorgefertigte MCC Schelle - J-Serie

Preformed MCC clamp - J-serie

Collier de serrage préfabriqué MCC - J-Serie

Abrazadera preformada MCC - J-Serie

Preformowane MCC Opaski zaciskowe - Seria J

Morsetto preformato MCC - J-Serie



Part-No.	Material	Band	ID	Width	Price
MJS201	SS 201	3/8"	20 mm	9,6 mm	
MJS243	SS 201	3/8"	25 mm	9,6 mm	
MJS202	SS 201	3/8"	34 mm	9,6 mm	
MJS245	SS 201	3/8"	50 mm	9,6 mm	
MJS246	SS 201	3/8"	76 mm	9,6 mm	
MJS255	SS 201	3/8"	88 mm	9,6 mm	
MJS240	SS 201	1/4"	20 mm	6,4 mm	
MJS242	SS 201	1/4"	25 mm	6,4 mm	
MJS241	SS 201	1/4"	34 mm	6,4 mm	
MJS252	SS 201	1/4"	38 mm	6,4 mm	
MJS253	SS 201	1/4"	50 mm	6,4 mm	
MJS256	SS 201	1/4"	69 mm	6,4 mm	
MJS244	SS 201	1/4"	76 mm	6,4 mm	
MJS257	SS 201	1/4"	88 mm	6,4 mm	



Vorgefertigte MCC Schelle

Preformed MCC clamp
 Collier de serrage préfabriqué MCC
 Abrazadera preformada MCC
 Preformowane MCC Opaski zaciskowe
 Morsetto preformato MCC

Part-No.	Material	Band	ID	Width	Price
MCP4S	SS 201	5/8"	25 mm	15,9 mm	
MCP5S	SS 201	5/8"	32 mm	15,9 mm	
MCP6S	SS 201	5/8"	38 mm	15,9 mm	
MCP7S	SS 201	5/8"	44 mm	15,9 mm	
MCP8S	SS 201	5/8"	51 mm	15,9 mm	
MCP9S	SS 201	5/8"	57 mm	15,9 mm	
MCP10S	SS 201	5/8"	64 mm	15,9 mm	
MCP11S	SS 201	5/8"	70 mm	15,9 mm	
MCP12S	SS 201	5/8"	76 mm	15,9 mm	
MCP14S	SS 201	5/8"	89 mm	15,9 mm	
MCP16S	SS 201	5/8"	102 mm	15,9 mm	
MCP18S	SS 201	5/8"	114 mm	15,9 mm	
MCP20S	SS 201	5/8"	127 mm	15,9 mm	
MCP24S	SS 201	5/8"	152 mm	15,9 mm	
MCP28S	SS 201	5/8"	178 mm	15,9 mm	



Spannwerkzeug

Tool
 Outil de fixation
 Herramienta tensora
 Narzędzie do mocowania taśmy
 Strumento di tensionamento

Part-No.	Using for	Price
MC0016	for use on band width 4,8 mm - 19,1 mm	
MG402	for use on band width 19,1 mm - 31,8 mm	
MT3006	Tool centre punch (3/8" Adaptor included)	

A detailed technical drawing of a flange assembly, showing two circular flanges with multiple bolt holes and various mechanical components. The drawing is rendered in a light, faded style. The text 'FLANSCH-ARMATUREN' is overlaid in the center in a dark purple font.

FLANSCH- ARMATUREN

Losflansch mit gerilltem Schlauchstutzen und Sicherungsbund
(Stutzen + Flansching)

Swivel flange coupling with serrated hose shank

Raccord à bride tournante douille annelée à collerette

Brida giratoria con espiga dentada y cuello de seguridad

Złącze kołnierzowe obrotowe z króćcem i z wiązką zabezpieczającą pod obejmy skorupowe

Flangia girevole con portagomma a resca e collare di sicurezza

FLANSCHARMATUREN



Part-No.	Material	Typ	WP	Dimension	Price
BS100R-SS	SS 316	Shank	PN10/16	25mm	
BS125R-SS	SS 316	Shank	PN10/16	32mm	
BS150R-SS-38	SS 316	Shank	PN10/16	38mm	
BS200R-SS	SS 316	Shank	PN10/16	50mm	
BS250R-SS-63	SS 316	Shank	PN10/16	63mm	
BS300R-SS-75	SS 316	Shank	PN10/16	75mm	
BS400R-SS	SS 316	Shank	PN10/16	100mm	
BP100-SS	SS 316	Flange	PN10/40	DN25	
BP125-SS	SS 316	Flange	PN10/40	DN32	
BP150-SS	SS 316	Flange	PN10/40	DN38	
BP200-SS	SS 316	Flange	PN10/16	DN50	
BP250-SS	SS 316	Flange	PN10/16	DN63	
BP300-SS	SS 316	Flange	PN10/16	DN75	
BP400-SS	SS 316	Flange	PN10/16	DN100	

Losflansch mit gerilltem Schlauchstutzen und Sicherungsbund

PFA ausgekleidet

Swivel flange coupling with serrated hose shank - PFA coated

Raccord à bride tournante douille annelée à collerette - Revêtu de PFA

Brida giratoria con espiga dentada y cuello de seguridad - Recubierto de PFA

Złącze kołnierzowe obrotowe z króćcem i z wiązką zabezpieczającą pod obejmy skorupowe - Z powłoką PFA

Flangia girevole con portagomma a resca e collare di sicurezza - Rivestimento in PFA

NEW

Part-No.	Material	WP	Coupling	Shank	Price
BS100R-SSPFA-W	SS 1.4408 PFA white coated	16 bar	DN25	25mm	
BS125R-SSPFA-W	SS 1.4408 PFA white coated	16 bar	DN32	32mm	
BS150R-SS-38PFA-W	SS 1.4408 PFA white coated	16 bar	DN40	38mm	
BS200R-SSPFA-W	SS 1.4408 PFA white coated	16 bar	DN50	50mm	
BS250R-SS-63PFA-W	SS 1.4408 PFA white coated	16 bar	DN65	63mm	
BS300R-SS-75PFA-W	SS 1.4408 PFA white coated	16 bar	DN80	75mm	
BS100R-SSPFA-B	SS 4408 PFA black coated	16 bar	DN25	25mm	
BS200R-SSPFA-B	SS 4408 PFA black coated	16 bar	DN50	50mm	
BS250R-SS-63PFA-B	SS 4408 PFA black coated	16 bar	DN65	63mm	
BS300R-SS-75PFA-B	SS 4408 PFA black coated	16 bar	DN80	75mm	



CONDUCTIVE

FLANSCHARMATUREN



Flanschgewindenippel, Flansch EN1092-1 (DIN2633)

mit Außengewinde (EN ISO 228/BSPP)

Fixed flange according EN1092-1 (DIN2633), with BSPP male thread

Raccord fileté à bride, bride EN1092-1 (DIN2633), filetage mâle (EN ISO 228/BSPP)

Brida fija EN 1092-1 (DIN2633) con rosca macho

Kotłierz EN10921-1 (DIN2633), z gwintem zewnętrznym (EN ISO 228/BSPP)

Flangia fissa EN 1092-1 (DIN2633) con filettatura maschio

FLANSCHARMATUREN

Part-No.	Material	Flange	Thread	Length	WP	Price
BFGN100SS	SS 316	DN25	1"	73 mm	PN16	
BFGN125SS	SS 316	DN32	1 1/4"	75 mm	PN16	
BFGN150200SS	SS 316	DN40	2"	87 mm	PN16	
BFGN150SS	SS 316	DN40	1 1/2"	77 mm	PN16	
BFGN200SS	SS 316	DN50	2"	90 mm	PN16	
BFGN200SS-109	SS 316	DN50	2"	109 mm	PN16	
BFGN250SS	SS 316	DN65	2 1/2"	90 mm	PN16	
BFGN250300SS	SS 316	DN65	3"	90 mm	PN16	
BFGN300SS	SS 316	DN75	3"	95 mm	PN16	
BFGN300SS-125	SS 316	DN75	3"	125 mm	PN16	
BFGN400SS	SS 316	DN100	4"	86 mm	PN16	

Losflansch mit gerilltem Schlauchstutzen und Sicherungsbund (Stutzen + Flansching)

Swivel flange coupling with serrated hose shank

Raccord à bride tournante douille annelée à collerette

Brida giratoria con espiga dentada y cuello de seguridad

Złącze kołnierzowe obrotowe z króćcem i z wiązką zabezpieczającą pod obejmy skorupowe

Flangia girevole con portagomma a resca e collare di sicurezza

Part-No.	Material	Typ	WP	Dimension	Price
BS100R-AC	Galvanized Steel	Shank	PN10/16	25mm	
BS125R-AC	Galvanized Steel	Shank	PN10/16	32mm	
BS150R-AC-38	Galvanized Steel	Shank	PN10/16	38mm	
BS200R-AC	Galvanized Steel	Shank	PN10/16	50mm	
BS250R-AC-63	Galvanized Steel	Shank	PN10/16	63mm	
BS300R-AC-75	Galvanized Steel	Shank	PN10/16	75mm	
BS400R-AC	Galvanized Steel	Shank	PN10/16	100mm	
BS500R-AC	Galvanized Steel	Shank	PN10	125mm	
BS600R-AC	Galvanized Steel	Shank	PN10	150mm	
BS800R-AC	Galvanized Steel	Shank	PN10	200mm	
BP100-AC	Galvanized Steel	Flange	PN10/40	DN25	
BP125-AC	Galvanized Steel	Flange	PN10/40	DN32	
BP150-AC	Galvanized Steel	Flange	PN10/40	DN40	
BP200-AC	Galvanized Steel	Flange	PN10/16	DN50	
BP250-AC	Galvanized Steel	Flange	PN10/16	DN65	
BP300-AC	Galvanized Steel	Flange	PN10/16	DN75	
BP400-AC	Galvanized Steel	Flange	PN10/16	DN100	
BP500-AC	Galvanized Steel	Flange	PN10	DN125	
BP600-AC	Galvanized Steel	Flange	PN10	DN150	
BP800-AC	Galvanized Steel	Flange	PN10	DN200	





Flanschgewindenippel, Flansch EN1092-1 (DIN2633)

mit Außengewinde (EN ISO 228/BSPP)

Fixed flange according EN1092-1 (DIN2633), with BSPP male thread

Raccord fileté à bride, bride EN1092-1 (DIN2633), filetage mâle (EN ISO 228/BSPP)

Brida fija EN 1092-1 (DIN2633) con rosca macho

Kotłierz EN10921-1 (DIN2633), z gwintem zewnętrznym (EN ISO 228/BSPP)

Flangia fissa EN 1092-1 (DIN2633) con filettatura maschio

Part-No.	Material	Flange	Thread	Length	WP	Price
BFGN100AC	Galvanized Steel	DN25	1"	73 mm	PN16	
BFGN125AC	Galvanized Steel	DN32	1 1/4"	75 mm	PN16	
BFGN150200AC	Galvanized Steel	DN40	2"	87 mm	PN16	
BFGN150AC	Galvanized Steel	DN40	1 1/2"	77 mm	PN16	
BFGN200AC	Galvanized Steel	DN50	2"	90 mm	PN16	
BFGN200AC-109	Galvanized Steel	DN50	2"	109 mm	PN16	
BFGN250AC	Galvanized Steel	DN65	2 1/2"	90 mm	PN16	
BFGN250300AC	Galvanized Steel	DN65	3"	90 mm	PN16	
BFGN300AC	Galvanized Steel	DN75	3"	95 mm	PN16	
BFGN300AC-125	Galvanized Steel	DN75	3"	125 mm	PN16	
BFGN400AC	Galvanized Steel	DN100	4"	86 mm	PN16	



FITTINGS & ZUBEHÖR

Fittings.....	374
Kugelhähne und Ventile.....	386
Prallschutz.....	390
Wasserparventile.....	394
Dichtungen.....	396
Zubehör.....	426



Muffe BSPT IG x IG

Female x female
 Manchon taraudé femelle - femelle
 Manguito hembra x hembra
 Mufa z gwintami zewnętrznymi cylindrycznymi
 Polsino femmina x femmina

Part-No.	Material	WP	Female	Female	Price
FF050PP	PVC	10 bar	1/2"	1/2"	
FF075PP	PVC	10 bar	3/4"	3/4"	
FF100PP	PVC	10 bar	1"	1"	
FF125PP	PVC	10 bar	1 1/4"	1 1/4"	
FF150PP	PVC	10 bar	1 1/2"	1 1/2"	
FF200PP	PVC	10 bar	2"	2"	



BSPT IG x BSPT AG

BSPT female x BSPT male
 BSPT fileté mâle - taraudé femelle
 hembra BSPT x macho BSPT
 z gwintem wewnętrznym BSPT x zewnętrznym BSPT
 BSPT femmina-maschio BSPT

Part-No.	Material	WP	Female	Male	Price
FM07520PP	Polypropylen	10 bar	3/4"	2"	
FM1020PP	Polypropylen	10 bar	1"	2"	
FM1220PP	Polypropylen	10 bar	1 1/4"	2"	
FM1520PP	Polypropylen	10 bar	1 1/2"	2"	

BSPT AG / BSPT AG

Double nipple male BSPT thread

Raccord double mâle/mâle

Machón doble BSPT

Nypel z gwintami zewnętrznymi cylindrycznymi

Maschio doppio BSPT



Part-No.	Material	WP	Male	Male	Price
MMP0505	Polypropylen	10 bar	1/2"	1/2"	
MMP075075	Polypropylen	10 bar	3/4"	3/4"	
MMP07520	Polypropylen	10 bar	3/4"	2"	
MMP1010	Polypropylen	10 bar	1"	1"	
MMP1020	Polypropylen	10 bar	1"	2"	
MMP1212	Polypropylen	10 bar	1 1/4"	1 1/4"	
MMP1220	Polypropylen	10 bar	1 1/4"	2"	
MMP1515	Polypropylen	10 bar	1 1/2"	1 1/2"	
MMP1520	Polypropylen	10 bar	1 1/2"	2"	
MMP2020	Polypropylen	10 bar	2"	2"	



Doppelnippel BSPP AG / BSPP AG flachdichtend

Hex-Nipple male BSPP thread - flat sealing

Raccord double mâle/mâle à joint plat

Machôn doble BSPP

Nypel z gwintami zewnętrznymi cylindrycznymi

Maschio doppio BSPP

Part-No.	Material	WP	Male	Male	Price
MML0505FL	Brass	16 bar	1/2"	1/2"	
MML075075FL	Brass	16 bar	3/4"	3/4"	
MML07510FL	Brass	16 bar	3/4"	1"	
MML1010FL	Brass	16 bar	1"	1"	
MML1012FL	Brass	16 bar	1"	1 1/4"	
MML1212FL	Brass	16 bar	1 1/4"	1 1/4"	
MML1215FL	Brass	16 bar	1 1/4"	1 1/2"	
MML1220FL	Brass	16 bar	1 1/4"	2"	
MML1510FL	Brass	16 bar	1 1/2"	1"	
MML1515FL	Brass	16 bar	1 1/2"	1"1/2	
MML1520FL	Brass	16 bar	1 1/2"	2"	
MML1525FL	Brass	16 bar	1 1/2"	2 1/2"	
MML2010FL	Brass	16 bar	2"	1"	
MML2020FL	Brass	16 bar	2"	2"	
MML2025FL	Brass	16 bar	2"	2 1/2"	
MML2525FL	Brass	16 bar	2 1/2"	2 1/2"	
MML2530FL	Brass	16 bar	2 1/2"	3"	
MML3020FL	Brass	16 bar	3"	2"	
MML3030FL	Brass	16 bar	3"	3"	
MML3040FL	Brass	16 bar	3"	4"	
MML4040FL	Brass	16 bar	4"	4"	

90° Bogen BSPP AG / BSPP AG flachdichtend

90° elbow male BSPP thread - flat sealing

90° Coude mâle/mâle à joint plat

Codo 90° RM-RM BSPP

90° Lolanoz gwintami zewnętrznymi cylindrycznymi

Curva 90° maschio - maschio BSPP



Part-No.	Material	WP	Male	Male	Price
MMA2020FL-90	Aluminum	10 bar	2"	2"	
MMA3030FL-90	Aluminum	10 bar	3"	3"	
MMA4040FL-90	Aluminum	10 bar	4"	4"	

90° Bogen BSPP AG / BSPP AG flachdichtend

90° elbow male BSPP thread - flat sealing

90° Coude mâle/mâle à joint plat

Codo 90° RM-RM BSPP

90° Lolanoz gwintami zewnętrznymi cylindrycznymi

Curva 90° maschio - maschio BSPP



Part-No.	Material	WP	Male	Male	Price
MMS075075FL-90	SS 316	16 bar	3/4"	3/4"	
MMS1010FL-90	SS 316	16 bar	1"	1"	
MMS1212FL-90	SS 316	16 bar	1 1/4"	1 1/4"	
MMS1515FL-90	SS 316	16 bar	1 1/2"	1 1/2"	
MMS2020FL-90	SS 316	16 bar	2"	2"	
MMS3030FL-90	SS 316	16 bar	3"	3"	
MMS4040FL-90	SS 316	16 bar	4"	4"	



Doppelnippel BSPP AG / BSPP AG flachdichtend

Hex-Nipple male BSPP thread - flat sealing

Raccord double mâle/mâle à joint plat

Machôn doble BSPP

Nypel z gwintami zewnętrznymi cylindrycznymi

Maschio doppio BSPP

Part-No.	Material	WP	Male	Male	Price
MMS0505FL	SS 316	16 bar	1/2"	1/2"	
MMS075075FL	SS 316	16 bar	3/4"	3/4"	
MMS07510FL	SS 316	16 bar	3/4"	1"	
MMS1010FL	SS 316	16 bar	1"	1"	
MMS1012FL	SS 316	16 bar	1"	1 1/4"	
MMS1212FL	SS 316	16 bar	1 1/4"	1 1/4"	
MMS1215FL	SS 316	16 bar	1 1/4"	1 1/2"	
MMS1220FL	SS 316	16 bar	1 1/4"	2"	
MMS1510FL	SS 316	16 bar	1 1/2"	1"	
MMS1515FL	SS 316	16 bar	1 1/2"	1 1/2"	
MMS1520FL	SS 316	16 bar	1 1/2"	2"	
MMS1525FL	SS 316	16 bar	1 1/2"	2 1/2"	
MMS2010FL	SS 316	16 bar	2"	1"	
MMS2020FL	SS 316	16 bar	2"	2"	
MMS2025FL	SS 316	16 bar	2"	2 1/2"	
MMS2525FL	SS 316	16 bar	2 1/2"	2 1/2"	
MMS2530FL	SS 316	16 bar	2 1/2"	3"	
MMS3020FL	SS 316	16 bar	3"	2"	
MMS3030FL	SS 316	16 bar	3"	3"	
MMS4030FL	SS 316	16 bar	3"	4"	
MMS4040FL	SS 316	16 bar	4"	4"	

Muffe BSPP IG / BSPP IG

Female x female

Manchon taraudé femelle - femelle

Manguito hembra x hembra

Mufa z gwintami zewnętrznymi cylindrycznymi

Polsino femmina x femmina



Part-No.	Material	WP	Female	Female	Price
FF0125SS	SS 316	10 bar	1/8"	1/8"	
FF025SS	SS 316	10 bar	1/4"	1/4"	
FF0375SS	SS 316	10 bar	3/8"	3/8"	
FF050SS	SS 316	10 bar	1/2"	1/2"	
FF075SS	SS 316	10 bar	3/4"	3/4"	
FF100SS	SS 316	10 bar	1"	1"	
FF125SS	SS 316	10 bar	1 1/4"	1 1/4"	
FF150SS	SS 316	10 bar	1 1/2"	1 1/2"	
FF200SS	SS 316	10 bar	2"	2"	

Reduzierung BSPP IG / BSPP IG flachdichtend

Reduction male BSPP thread - flat sealing

Réduction double femelle/femelle à joint plat

Reducción rosca hembra BSPP - rosca hembra BSPP

Redukcja z gwintami zewnętrznymi cylindrycznymi

Riduzione filettato femmina BSPP - Filettato femmina BSP



Part-No.	Material	WP	Female	Female	Price
FFA6040FL	Aluminum	-	6"	4"	



Reduzierung BSPP IG / BSPP IG - mit kurzem Gewinde

Reduction female BSPP thread - with short thread
 Réduction double femelle/femelle - avec filetage court
 Reducción rosca hembra BSPP - con rosca corta
 Redukcja z gwintami - z krótkim gwintem
 Riduzione filettato femmina BSPP - con filo corto

Part-No.	Material	WP	Female	Female	Price
FFA2015	Aluminum	16 bar	2"	1 1/2"	
FFA2515	Aluminum	16 bar	2 1/2"	1 1/2"	
FFA2520	Aluminum	16 bar	2 1/2"	2"	
FFA3015	Aluminum	16 bar	3"	1 1/2"	
FFA3020	Aluminum	16 bar	3"	2"	
FFA3025	Aluminum	16 bar	3"	2 1/2"	
FFA4015	Aluminum	16 bar	4"	1 1/2"	
FFA4020	Aluminum	16 bar	4"	2"	
FFA4025	Aluminum	16 bar	4"	2 1/2"	
FFA4030	Aluminum	16 bar	4"	3"	



Reduzierung BSPP AG / BSPP IG mit NBR Gewindedichtung

Reduction male female BSPP thread - NBR gasket
 Réduction double mâle/femelle - joint NBR
 Reducción rosca macho hembra BSPP - Junta NBR
 Redukcja z gwintami - Uszczelka NBR
 Riduzione filettato maschio femmina BSPP - guarnizione NBR

NEW

Part-No.	Material	WP	Male	Female	Price
MFA1015FL	Aluminum	x bar	1"	1 1/2"	
MFA1020FL	Aluminum	x bar	1"	1 1/2"	
MFA1520FL	Aluminum	x bar	2 1/2"	2"	
MFA2025FL	Aluminum	x bar	2"	2 1/2"	
MFA2030FL	Aluminum	x bar	2"	3"	
MFA2530FL	Aluminum	x bar	2 1/2"	3"	
MFA3040FL	Aluminum	x bar	3"	4"	

Union Con mit Überwurfmutter mit BSPP IG / BSPP IG

Union Con BSPP female/female

Union BSPP femelle-femelle

«Union Con» BSPP hembra / hembra

Śrubunek rurowy - z gwintami wewnętrznymi cylindrycznymi BSPP

«Union Con» BSPP filettatura femmina / femmina



Part-No.	Material	WP	Female	Female	Price
SUCFF-0.125	SS 316	10 bar	1/8"	1/8"	
SUCFF-0.25	SS 316	10 bar	1/4"	1/4"	
SUCFF-0.375	SS 316	10 bar	3/8"	3/8"	
SUCFF-0.5	SS 316	10 bar	1/2"	1/2"	
SUCFF-0.75	SS 316	10 bar	3/4"	3/4"	
SUCFF-1.0	SS 316	10 bar	1"	1"	
SUCFF-1.25	SS 316	10 bar	1 1/4"	1 1/4"	
SUCFF-1.5	SS 316	10 bar	1 1/2"	1 1/2"	
SUCFF-2.0	SS 316	10 bar	2"	2"	

6|8 Kant BSPT Außengewinde mit Rillenstutzen

Male jose fitting, serrated hose shank and hexagon|octagon

Filetage mâle BSPT 6|8-edge BSPT avec embout cannelé

Entronque rosca macho con espiga dentada

Ześciokątny/ośmiokątny gwint zewnętrzny BSPT z króćcem karbowanym do węża

Portagomma a resca filettato maschio



Part-No.	Material	WP	Male	Mold	Shank	Price
SHN-0.125	SS 316	10 bar	1/8"	hexagon	7mm	
SHN-0.25	SS 316	10 bar	1/4"	hexagon	9mm	
SHN-0.375	SS 316	10 bar	3/8"	hexagon	11mm	
SHN-0.5	SS 316	10 bar	1/2"	hexagon	12,7mm	
SHN-0.5-17	SS 316	10 bar	1/2"	hexagon	17mm	
SHN-0.75	SS 316	10 bar	3/4"	hexagon	20mm	
SHN-1.0	SS 316	10 bar	1"	hexagon	26mm	
SHN-1.25	SS 316	10 bar	1 1/4"	octagon	33mm	
SHN-1.5	SS 316	10 bar	1 1/2"	octagon	38,1mm	
SHN-2.0	SS 316	10 bar	2"	octagon	51mm	



Kreuz-Stück - BSPP IG

Cross piece BSPP female
 Croix taraudée femelle BSPP
 Pieza en cruz BSPP hembra
 Czwórnik z gwintami wewnętrznymi cylindrycznymi BSPP
 Pezza in croce femmina BSPP

Part-No.	Material	WP	Female	Female	Female	Female	Price
SC-0.25	SS 316	10 bar	1/4"	1/4"	1/4"	1/4"	
SC-0.375	SS 316	10 bar	3/8"	3/8"	3/8"	3/8"	
SC-0.5	SS 316	10 bar	1/2"	1/2"	1/2"	1/2"	
SC-0.75	SS 316	10 bar	3/4"	3/4"	3/4"	3/4"	
SC-1.0	SS 316	10 bar	1"	1"	1"	1"	
SC-1.25	SS 316	10 bar	1 1/4"	1 1/4"	1 1/4"	1 1/4"	
SC-1.5	SS 316	10 bar	1 1/2"	1 1/2"	1 1/2"	1 1/2"	
SC-2.0	SS 316	10 bar	2"	2"	2"	2"	



45° Bogen BSPP IG x BSPP IG

45° elbow BSPP female x BSPP female
 Coude 45° femelle-femelle
 Codo 45° BSPP hembra x hembra BSPP
 45° Kolano z gwintami wewnętrznymi cylindrycznymi BSPP
 Curva 45° BSPP femmina-femmina BSPP

Part-No.	Material	WP	Female	Female	Price
SE45FF-0.125	SS 316	10 bar	1/8"	1/8"	
SE45FF-0.25	SS 316	10 bar	1/4"	1/4"	
SE45FF-0.375	SS 316	10 bar	3/8"	3/8"	
SE45FF-0.5	SS 316	10 bar	1/2"	1/2"	
SE45FF-0.75	SS 316	10 bar	3/4"	3/4"	
SE45FF-1.0	SS 316	10 bar	1"	1"	
SE45FF-1.25	SS 316	10 bar	1 1/4"	1 1/4"	
SE45FF-1.5	SS 316	10 bar	1 1/2"	1 1/2"	
SE45FF-2.0	SS 316	10 bar	2"	2"	

90° Bogen BSPP IG x BSPP IG

90° elbow BSPP female x BSPP female

Coude 90° femelle-femelle

Codo 90° hembra x hembra BSPP

90° Kolano z gwintami wewnętrznymi cylindrycznymi BSPP

Curva 90° BSPP femmina-femmina BSPP



Part-No.	Material	WP	Female	Female	Price
SE90FF-0.125	SS 316	10 bar	1/8"	1/8"	
SE90FF-0.25	SS 316	10 bar	1/4"	1/4"	
SE90FF-0.375	SS 316	10 bar	3/8"	3/8"	
SE90FF-0.5	SS 316	10 bar	1/2"	1/2"	
SE90FF-0.75	SS 316	10 bar	3/4"	3/4"	
SE90FF-1.0	SS 316	10 bar	1"	1"	
SE90FF-1.25	SS 316	10 bar	1 1/4"	1 1/4"	
SE90FF-1.5	SS 316	10 bar	1 1/2"	1 1/2"	
SE90FF-2.0	SS 316	10 bar	2"	2"	

90° Bogen BSPP IG x BSPT AG

90° elbow BSPP female x BSPT male

Coude 90° mâle-femelle

Codo 90° hembra BSPP x macho BSPT

90° Kolano z gwintem wewnętrznym BSPP x zewnętrznym BSPT

Curva 45° BSPP femmina-maschio BSPP



Part-No.	Material	WP	Female	Male	Price
SE90FM-0.25	SS 316	10 bar	1/4"	1/4"	
SE90FM-0.375	SS 316	10 bar	3/8"	3/8"	
SE90FM-0.5	SS 316	10 bar	1/2"	1/2"	
SE90FM-0.75	SS 316	10 bar	3/4"	3/4"	
SE90FM-1.0	SS 316	10 bar	1"	1"	
SE90FM-1.25	SS 316	10 bar	1 1/4"	1 1/4"	
SE90FM-1.5	SS 316	10 bar	1 1/2"	1 1/2"	
SE90FM-2.0	SS 316	10 bar	2"	2"	



T-Stück BSPP IG x BSPP IG x BSPP IG

T-Fitting BSPP female x BSPP female x BSPP female

Té taraudé femelle BSPP

T con roscas hembra BSPP

Trójnik z gwintami wewnętrznymi cylindrycznymi BSPP

T con filettatura femmina BSPP

Part-No.	Material	WP	Female	Female	Female	Price
ST-0.125	SS 316	10 bar	1/8"	1/8"	1/8"	
ST-0.25	SS 316	10 bar	1/4"	1/4"	1/4"	
ST-0.375	SS 316	10 bar	3/8"	3/8"	3/8"	
ST-0.5	SS 316	10 bar	1/2"	1/2"	1/2"	
ST-0.75	SS 316	10 bar	3/4"	3/4"	3/4"	
ST-1.0	SS 316	10 bar	1"	1"	1"	
ST-1.25	SS 316	10 bar	1 1/4"	1 1/4"	1 1/4"	
ST-1.5	SS 316	10 bar	1 1/2"	1 1/2"	1 1/2"	
ST-2.0	SS 316	10 bar	2"	2"	2"	



Kappe, 6|8 Kant mit BSPP IG

Hex|Octagon cap with BSPP female

Bouchon hexagonal / octogonal avec taraudage femelle BSPP

Tapá hexágono/octágono con rosca hembra BSPP

Zaślepka ześciokątna/ośmiokątna z gwintem wewnętrznym cylindrycznym

Tappo esagonale / ottagonno con filettatura femmina BSPP

Part-No.	Material	WP	Female	Mold	Price
SHC-0.125	SS 316	10 bar	1/8"	hexagon	
SHC-0.25	SS 316	10 bar	1/4"	hexagon	
SHC-0.375	SS 316	10 bar	3/8"	hexagon	
SHC-0.5	SS 316	10 bar	1/2"	hexagon	
SHC-0.75	SS 316	10 bar	3/4"	hexagon	
SHC-1.0	SS 316	10 bar	1"	octagon	
SHC-1.25	SS 316	10 bar	1 1/4"	octagon	
SHC-1.5	SS 316	10 bar	1 1/2"	octagon	
SHC-2.0	SS 316	10 bar	2"	octagon	

Stopfen, 6|8-Kant mit BSPT AG

Hex|Octagon-plug with BSPT male

Bouchon hexagonal / octogonal avec filetage BSPT

Tapón hexágono / octágono con rosca BSPT

Korek sześciokątny/ośmiokątny z gwintem zewnętrznym BSPT

Tappo esagonale / ottagonno con filettatura BSPT



Part-No.	Material	WP	Male	Mold	Price
SHP-0.125	SS 316	10 bar	1/8"	hexagon	
SHP-0.25	SS 316	10 bar	1/4"	hexagon	
SHP-0.375	SS 316	10 bar	3/8"	hexagon	
SHP-0.5	SS 316	10 bar	1/2"	hexagon	
SHP-0.75	SS 316	10 bar	3/4"	hexagon	
SHP-1.0	SS 316	10 bar	1"	octagon	
SHP-1.25	SS 316	10 bar	1 1/4"	octagon	
SHP-1.5	SS 316	10 bar	1 1/2"	octagon	
SHP-2.0	SS 316	10 bar	2"	octagon	

Stopfen, Vierkant mit BSPT AG

Square plug with BSPT male

Bouchon mâle avec collet

Tapón cuadrado con rosca macho BSPT

Korek kwadratowy z gwintem zewnętrznym BSPT

Tappo quadrato con filetto maschio BSPTT



Part-No.	Material	WP	Male	Price
SSP-0.125	SS 316	10 bar	1/8"	
SSP-0.25	SS 316	10 bar	1/4"	
SSP-0.375	SS 316	10 bar	3/8"	
SSP-0.5	SS 316	10 bar	1/2"	
SSP-0.75	SS 316	10 bar	3/4"	
SSP-1.0	SS 316	10 bar	1"	
SSP-1.25	SS 316	10 bar	1 1/4"	
SSP-1.5	SS 316	10 bar	1 1/2"	
SSP-2.0	SS 316	10 bar	2"	



Wasserhahn BSPT AG mit AG Auslaufgewinde auf Stutzen

Ball valve with BSPT male thread and outlet tap BSPT male thread with hose shank

Vanne avec filetage mâle BSPT et robinet de sortie filetage mâle BSPT avec tige de tuyau

Válvula de bola con rosca macho BSPT y grifo de salida

Zawór kulowy z gwintem zewnętrznym BSPT i kurkiem wylotowym z gwintem zewnętrznym BSPT z trzpieniem do węża

Valvola a sfera con filettatura maschio

Part-No.	Material	WP	Thread	Thread	Shank	Price
BBV050HT015	Brass chromated	16 bar	1/2"	3/4"	15mm (SS201)	
BBV075HT020	Brass chromated	16 bar	3/4"	1"	20mm (SS201)	
BBV100HT025	Brass chromated	16 bar	1"	1 1/4"	25mm (SS201)	



Kugelhahn - IG/IG (arretierbarer Griff) voller Durchgang - PTFE Dichtung

Ball valves female/female thread (lockable handle), full passage - PTFE gasket

Vanne 2 pièces passage intégral femelle/femelle BSP - Joint PTFE

Valvula de bola roscada, dos piezas - PTFE Junta

Zawór kulowy z gwintami wewnętrznymi (zamykana dźwignia) z pełnym przelotem - PTFE Uszczelka

Valvola a sfera in due pezzi - filettatura femmina - guarnizione in PTFE

Part-No.	Material	WP	Dimenson	Thread	Price
SSBV025-2	SS 316	25 bar	DN8	1/4"	
SSBV038-2	SS 316	25 bar	DN10	3/8"	
SSBV050-2	SS 316	25 bar	DN15	1/2"	
SSBV075-2	SS 316	25 bar	DN19	3/4"	
SSBV100-2	SS 316	25 bar	DN25	1"	
SSBV125-2	SS 316	25 bar	DN32	1 1/4"	
SSBV150-2	SS 316	25 bar	DN38	1 1/2"	
SSBV200-2	SS 316	25 bar	DN50	2"	
SSBV250-2	SS 316	25 bar	DN65	2 1/2"	
SSBV300-2	SS 316	25 bar	DN80	3"	
SSBV400-2	SS 316	25 bar	DN100	4"	

Minikugelhahn IG / IG

Mini ball valve female/female thread
 Robinet «mini» femelle/femelle
 Mini válvula hembra/hembra
 Zawór kulowy - Mini - z gwintami wewnętrznymi
 Mini valvola femmina / femmina



Part-No.	Material	WP	Dimension	Thread	Price
BMBV025	Brass chromated	16 bar	DN8	1/4"	

PE Fasshahn mit BSPP AG

Polyethylen barrel tap with BSPP male thread
 Robinet de fût PE avec filetage mâle
 Grifo de PE para barril con rosca macho
 Kran beczkowy PE z gwintem zewnętrznym
 Rubinetto da barile in PE con filettatura maschio



Part-No.	Description	Material	Dimension	Thread	Price
BSPM075TAP	without Gasket	Polyethylen	DN19	3/4"	
BSPM200TAP	with Gasket	Polyethylen	DN50	2"	

Saugkorb mit Schlauchstutzen

Tin can strainer
 Crépine
 Lata colador
 Kosz ssawny z końcówką do węża
 Filtro del barattolo di latta



Part-No.	Material	Dimension	Price
TS100	Steel galvanized	DN25	
TS150	Steel galvanized	DN38	
TS200	Steel galvanized	DN50	
TS250	Steel galvanized	DN65	
TS300	Steel galvanized	DN80	
TS400	Steel galvanized	DN100	
TS600	Steel galvanized	DN150	
TS800	Steel galvanized	DN200	

FITTINGS & ZUBEHÖR

Kugelhahn - BSPT IG / BSPT IG, voller Durchgang

Ball valve female / female BSP, full passage

Vanne à sphère passage intégral femelle/femelle BSP

Válvula de bola hembra / hembra BSP

Zawór kulowy z gwintami wewnętrznymi z pełnym przelotem

Valvola a sfera femmina / femmina BSP



FITTINGS & ZUBEHÖR

Part-No.	Colour	Material	WP	Dimensin	Thread	Price
PBV050-B	Blue	PVC	10 bar	DN15	1/2"	
PBV075-B	Blue	PVC	10 bar	DN19	3/4"	
PBV100-B	Blue	PVC	10 bar	DN25	1"	
PBV125-B	Blue	PVC	10 bar	DN32	1 1/4"	
PBV150-B	Blue	PVC	10 bar	DN38	1 1/2"	
PBV200-B	Blue	PVC	10 bar	DN50	2"	
PBV250-B	Blue	PVC	10 bar	DN65	2 1/2"	
PBV300-B	Blue	PVC	10 bar	DN80	3"	
PBV400-B	Blue	PVC	10 bar	DN100	4"	
PBV050-W	White	PVC	10 bar	DN15	1/2"	
PBV075-W	White	PVC	10 bar	DN19	3/4"	
PBV100-W	White	PVC	10 bar	DN25	1"	
PBV125-W	White	PVC	10 bar	DN32	1 1/4"	
PBV150-W	White	PVC	10 bar	DN38	1 1/2"	
PBV200-W	White	PVC	10 bar	DN50	2"	
PBV250-W	White	PVC	10 bar	DN65	2 1/2"	
PBV300-W	White	PVC	10 bar	DN80	3"	
PBV400-W	White	PVC	10 bar	DN100	4"	

20 bar Platzdruck

20 bar Burst Pressure

Kugelhahn - BSPT IG / BSPT IG, voller Durchgang

Ball valve female / female BSP, full passage

Vanne à sphère passage intégral femelle/femelle BSP

Válvula de bola hembra / hembra BSP

Zawór kulowy z gwintami wewnętrznymi z pełnym przelotem

Valvola a sfera femmina / femmina BSP

Part-No.	Colour	Material	WP	Dimensin	Thread	Price
PBV050-G	Grey	PVC	10 bar	DN15	1/2"	
PBV075-G	Grey	PVC	10 bar	DN19	3/4"	
PBV100-G	Grey	PVC	10 bar	DN25	1"	
PBV125-G	Grey	PVC	10 bar	DN32	1 1/4"	
PBV150-G	Grey	PVC	10 bar	DN38	1 1/2"	
PBV200-G	Grey	PVC	10 bar	DN50	2"	
PBV250-G	Grey	PVC	10 bar	DN65	2 1/2"	
PBV300-G	Grey	PVC	10 bar	DN80	3"	
PBV400-G	Grey	PVC	10 bar	DN100	4"	

20 bar Platzdruck

20 bar Burst Pressure



Prallschutz

Protection ring

Anneau de protection

Anillo de protección

Ochrona przed uderzeniami

Anello di protezione



FITTINGS & ZUBEHÖR

Part-No.	Colour	Material	Shore°	DN	ID ø	OD ø	Price
RDP025B	Blue	NR	45	DN25	35mm	95mm	
RDP025B-37	Blue	NR	45	DN25	37mm	95mm	
RDP032B	Blue	NR	45	DN32	44mm	103mm	
RDP038B	Blue	NR	45	DN38	45mm	105mm	
RDP040B	Blue	NR	45	DN40	51mm	105mm	
RDP040B-54	Blue	NR	45	DN40	54mm	115mm	
RDP040B-58	Blue	NR	45	DN40	58mm	115mm	
RDP050B	Blue	NR	45	DN50	60mm	115mm	
RDP050B-66	Blue	NR	45	DN50	66mm	115mm	
RDP065B	Blue	NR	45	DN65	70mm	130mm	
RDP065B-89	Blue	NR	45	DN65	89mm	130mm	
RDP070B	Blue	NR	45	DN70	78mm	145mm	
RDP075B	Blue	NR	45	DN75	85mm	145mm	
RDP025R	Red	NR	45	DN25	35mm	95mm	
RDP025R-37	Red	NR	45	DN25	37mm	95mm	
RDP032R	Red	NR	45	DN32	44mm	103mm	
RDP038R	Red	NR	45	DN38	45mm	105mm	
RDP040R	Red	NR	45	DN40	51mm	105mm	
RDP040R-54	Red	NR	45	DN40	54mm	115mm	
RDP040R-58	Red	NR	45	DN40	58mm	115mm	
RDP050R	Red	NR	45	DN50	60mm	115mm	
RDP050R-66	Red	NR	45	DN50	66mm	115mm	
RDP065R	Red	NR	45	DN65	70mm	130mm	
RDP065R-89	Red	NR	45	DN65	89mm	130mm	
RDP070R	Red	NR	45	DN70	78mm	145mm	
RDP075R	Red	NR	45	DN75	85mm	145mm	

Prallschutz

Protection ring

Anneau de protection

Anillo de protección

Ochrona przed uderzeniami

Anello di protezione

Part-No.	Colour	Material	Shore°	DN	ID ø	OD ø	Price
RDP025S	Black	NR	45	DN25	35mm	95mm	
RDP025S-37	Black	NR	45	DN25	37mm	95mm	
RDP032S	Black	NR	45	DN32	44mm	103mm	
RDP038S	Black	NR	45	DN38	45mm	105mm	
RDP040S	Black	NR	45	DN40	51mm	105mm	
RDP040S-54	Black	NR	45	DN40	54mm	115mm	
RDP040S-58	Black	NR	45	DN40	58mm	115mm	
RDP050S	Black	NR	45	DN50	60mm	115mm	
RDP050S-66	Black	NR	45	DN50	66mm	115mm	
RDP065S	Black	NR	45	DN65	70mm	130mm	
RDP065S-89	Black	NR	45	DN65	89mm	130mm	
RDP070S	Black	NR	45	DN70	78mm	145mm	
RDP075S	Black	NR	45	DN75	85mm	145mm	
RDP025W	White	NR	45	DN25	35mm	95mm	
RDP025W-37	White	NR	45	DN25	37mm	95mm	
RDP032W	White	NR	45	DN32	44mm	103mm	
RDP038W	White	NR	45	DN38	45mm	105mm	
RDP040W	White	NR	45	DN40	51mm	105mm	
RDP040W-54	White	NR	45	DN40	54mm	115mm	
RDP040W-58	White	NR	45	DN40	58mm	115mm	
RDP050W	White	NR	45	DN50	60mm	115mm	
RDP050W-66	White	NR	45	DN50	66mm	115mm	
RDP065W	White	NR	45	DN65	70mm	130mm	
RDP065W-89	White	NR	45	DN65	89mm	130mm	
RDP070W	White	NR	45	DN70	78mm	145mm	
RDP075W	White	NR	45	DN75	85mm	145mm	



2-teiliger Prallschutz für Schlauchleitungen

2 pieces protection ring for hose

Rondelle de protection

Anillo de protección de dos piezas para manguera

2 częściowa ochrona przed uderzeniami do węży

Anello di protezione del tubo in due pezzi



Part-No.	Colour	Material	DN	Hose	Size	Price
RDP25x6B	Blue	NBR	25	25x6	34-38	
RDP32x6B	Blue	NBR	32	32x6	42-46	
RDP38x6,5B	Blue	NBR	38	38x6,5	48-53	
RDP38x8B	Blue	NBR	38	38x8	53-57	
RDP50x6B	Blue	NBR	50	50x6	59-64	
RDP50x8B	Blue	NBR	50	50x8	65-70	
RDP75x8B	Blue	NBR	75	75x8	87-91	
RDP75x10B	Blue	NBR	75	75x10	95-99	
RDP100x8B	Blue	NBR	100	100x8	114-119	
RDP25x6R	Red	NBR	25	25x6	34-38	
RDP32x6R	Red	NBR	32	32x6	42-46	
RDP38x6,5R	Red	NBR	38	38x6,5	48-53	
RDP38x8R	Red	NBR	38	38x8	53-57	
RDP50x6R	Red	NBR	50	50x6	59-64	
RDP50x8R	Red	NBR	50	50x8	65-70	
RDP75x8R	Red	NBR	75	75x8	87-91	
RDP75x10R	Red	NBR	75	75x10	95-99	
RDP100x8R	Red	NBR	100	100x8	114-119	
RDP25x6S	Black	NBR	25	25x6	34-38	
RDP32x6S	Black	NBR	32	32x6	42-46	
RDP38x6,5S	Black	NBR	38	38x6,5	48-53	
RDP38x8S	Black	NBR	38	38x8	53-57	
RDP50x6S	Black	NBR	50	50x6	59-64	
RDP50x8S	Black	NBR	50	50x8	65-70	
RDP75x8S	Black	NBR	75	75x8	87-91	
RDP75x10S	Black	NBR	75	75x10	95-99	
RDP100x8S	Black	NBR	100	100x8	114-119	

2-teiliger Prallschutz für Schlauchleitungen

2 pieces protection ring for hose

Rondelle de protection

Anillo de protección de dos piezas para manguera

2 częściowa ochrona przed uderzeniami do węży

Anello di protezione del tubo in due pezzi

Part-No.	Colour	Material	DN	Hose	Size	Price
RDP25x6W	White	NBR	25	25x6	34-38	
RDP32x6W	White	NBR	32	32x6	42-46	
RDP38x6,5W	White	NBR	38	38x6,5	48-53	
RDP38x8W	White	NBR	38	38x8	53-57	
RDP50x6W	White	NBR	50	50x6	59-64	
RDP50x8W	White	NBR	50	50x8	65-70	
RDP75x8W	White	NBR	75	75x8	87-91	
RDP75x10W	White	NBR	75	75x10	95-99	
RDP100x8W	White	NBR	100	100x8	114-119	
RDP25x6G	Yellow	NBR	25	25x6	34-38	
RDP32x6G	Yellow	NBR	32	32x6	42-46	
RDP38x6,5G	Yellow	NBR	38	38x6,5	48-53	
RDP38x8G	Yellow	NBR	38	38x8	53-57	
RDP50x6G	Yellow	NBR	50	50x6	59-64	
RDP50x8G	Yellow	NBR	50	50x8	65-70	
RDP75x8G	Yellow	NBR	75	75x8	87-91	
RDP75x10G	Yellow	NBR	75	75x10	95-99	
RDP100x8G	Yellow	NBR	100	100x8	114-119	



Wassersparventil mit Silikon Gummierung mit BSPP Innengewinde

Wash down gun with silicone rubber with BSPP female thread
 Pistolet de lavage avec taraudage femelle BSPP
 Pistola de agua para limpieza industrial - rosca hembra BSPP '
 Pistolet do wody z gumowym pokryciem z gwintem wewnętrznym BSPP
 Pistola per lavaggio in gomma siliconica blu con filettatura femmina ' BSPT

NEW



Part-No.	Colour	Material	Temperature	Thread	Price
CDG75B	Blue	Brass	65° C	1/2"	
CDG75SS	Blue	SS 304	95° C	1/2"	
CDG75B-R	Red	Brass	65° C	1/2"	
CDG75SS-R	Red	SS 304	95° C	1/2"	

Max. Durchflussrate 30 l/min 5 bar ~ 80 l/min 24 bar
 Max. Flow 30 l/min 5 bar ~ 80 l/min 24 bar

FITTINGS & ZUBEHÖR

Griffschutz für Wassersparventil

Protection frame for washgun
 Protection de la poignée de la valve du pistolet
 Protector para la mano
 Zabezpieczenie uchwytu dla zaworu oszczędzania wody
 Protezione della mano della pistola per lavaggio



Part-No.	Colour	Material	Price
CDGS	blue silicon cover	SS 304	



Example

Schlauchtülle, drehbar mit 1/2" Außengewinde

Rotable hose shank with 1/2" male thread

Pistolet de lavage 1/2" filetage mâle BSPP

Giratorio rosca macho 1/2" para pistola de limpieza industrial

Końcówka obrotowa do węża z 1/2" gwintem zewnętrznym

Girevole con 1/2" maschio



Part-No.	Material	Thread	Hose	Price
MT13SS	SS 304	1/2"	DN13	
MT19SS	SS 304	1/2"	DN19	
MT13	Brass	1/2"	DN13	
MT19	Brass	1/2"	DN19	

Lippendichtung für TW - Kronenring

Lipgasket for TW crown ring

Joint pour raccord Tankwagen

Junta para corona

Uszczelka profilowa do TW pierścień koronowy

Guarnizione per corona



Part-No.	Colour	Material	Dimension	Price
2MKV	black	FKM	DN50	
3MKV	black	FKM	DN80	
4MKV*	black	FKM	DN100	
2MKG	green	CSM	DN50	
3MKG	green	CSM	DN80	
4MKG*	green	CSM	DN100	
2MKN	black	NBR	DN50	
3MKN	black	NBR	DN80	
4MKN*	black	NBR	DN100	
2MKNB	blue	NBR	DN50	
3MKNB	blue	NBR	DN80	
4MKNB*	blue	NBR	DN100	
2MKNW	white	NBR	DN50	
3MKNW	white	NBR	DN80	
4MKNW*	white	NBR	DN100	

*DN100 O-Ring keine Lippendichtung

*DN100 O-Ring no Lipgasket



Dichtung für TW - Kappe

Tankwagon cap gasket

Joint pour raccord Tankwagen cap

Junta tapa Tankwagen

Uszczelka do TW Pokrywy

Guarnizioni per tappi Tankwagen

Part-No.	Colour	Material	Dimension	Price
2MBN	black	NBR	DN50	
3MBN	black	NBR	DN80	
4MBN	black	NBR	DN100	
2MBNW	white	NBR	DN50	
3MBNW	white	NBR	DN80	
4MBNW	white	NBR	DN100	
2MBH	green	CSM	DN50	
3MBH	green	CSM	DN80	
4MBH	green	CSM	DN100	
2MBV	black	FKM	DN50	
3MBV	black	FKM	DN80	
4MBV	black	FKM	DN100	



Kupplungsdichtung für Kamlok

Gasket for Camlock female coupling

Joint pour Camlock femelle

Junta para Camlock hembra

Uszczelki do Camlock Kobiety

Guarnizione per Camlock femmina



Part-No.	Colour	Material	Dimension	Price
050B	black - blue Marking	NBR	DN15	
075B	black - blue Marking	NBR	DN20	
100B	black - blue Marking	NBR	DN25	
125B	black - blue Marking	NBR	DN32	
150B	black - blue Marking	NBR	DN40	
200B	black - blue Marking	NBR	DN50	
250B	black - blue Marking	NBR	DN65	
300B	black - blue Marking	NBR	DN80	
400B	black - blue Marking	NBR	DN100	
500B	black - blue Marking	NBR	DN125	
600B	black - blue Marking	NBR	DN150	
800B	black - blue Marking	NBR	DN200	
050E	black - white Marking	EPDM	DN15	
075E	black - white Marking	EPDM	DN20	
100E	black - white Marking	EPDM	DN25	
125E	black - white Marking	EPDM	DN32	
150E	black - white Marking	EPDM	DN40	
200E	black - white Marking	EPDM	DN50	
250E	black - white Marking	EPDM	DN65	
300E	black - white Marking	EPDM	DN80	
400E	black - white Marking	EPDM	DN100	
500E	black - white Marking	EPDM	DN125	
600E	black - white Marking	EPDM	DN150	

Kupplungsdichtung für Kamlok

Gasket for Camlock female coupling

Joint pour Camlock femelle

Junta para Camlock hembra

Uszczelki do Camlock Kobiety

Guarnizione per Camlock femmina

Part-No.	Colour	Material	Dimension	Price
050V	black - yellow Marking	FKM	DN15	
075V	black - yellow Marking	FKM	DN20	
100V	black - yellow Marking	FKM	DN25	
125V	black - yellow Marking	FKM	DN32	
150V	black - yellow Marking	FKM	DN40	
200V	black - yellow Marking	FKM	DN50	
250V	black - yellow Marking	FKM	DN65	
300V	black - yellow Marking	FKM	DN80	
400V	black - yellow Marking	FKM	DN100	
500V	black - yellow Marking	FKM	DN125	
600V	black - yellow Marking	FKM	DN150	
050H	green	CSM	DN15	
075H	green	CSM	DN20	
100H	green	CSM	DN25	
125H	green	CSM	DN32	
150H	green	CSM	DN40	
200H	green	CSM	DN50	
250H	green	CSM	DN65	
300H	green	CSM	DN80	
400H	green	CSM	DN100	
600H	green	CSM	DN150	



Kupplungsdichtung für Kamlok

Gasket for Camlock female coupling

Joint pour Camlock femelle

Junta para Camlock hembra

Uszczelki do Camlock Kobiety

Guarnizione per Camlock femmina



Part-No.	Colour	Material	Dimension	Price
050TB	white - open laterally	NBR/PTFE	DN15	
075TB	white - open laterally	NBR/PTFE	DN20	
100TB	white - open laterally	NBR/PTFE	DN25	
125TB	white - open laterally	NBR/PTFE	DN32	
150TB	white - open laterally	NBR/PTFE	DN40	
200TB	white - open laterally	NBR/PTFE	DN50	
250TB	white - open laterally	NBR/PTFE	DN65	
300TB	white - open laterally	NBR/PTFE	DN80	
400TB	white - open laterally	NBR/PTFE	DN100	
050TV	white - open laterally	FKM/PTFE	DN15	
075TV	white - open laterally	FKM/PTFE	DN20	
100TV	white - open laterally	FKM/PTFE	DN25	
125TV	white - open laterally	FKM/PTFE	DN32	
150TV	white - open laterally	FKM/PTFE	DN40	
200TV	white - open laterally	FKM/PTFE	DN50	
250TV	white - open laterally	FKM/PTFE	DN65	
300TV	white - open laterally	FKM/PTFE	DN80	
400TV	white - open laterally	FKM/PTFE	DN100	

Kupplungsdichtung für Kamlok

Gasket for Camlock female coupling

Joint pour Camlock femelle

Junta para Camlock hembra

Uszczelki do Camlock Kobiety

Guarnizione per Camlock femmina

Part-No.	Colour	Material	Dimension	Price
050TE	white - open laterally	EPDM/PTFE	DN15	
075TE	white - open laterally	EPDM/PTFE	DN20	
100TE	white - open laterally	EPDM/PTFE	DN25	
125TE	white - open laterally	EPDM/PTFE	DN32	
150TE	white - open laterally	EPDM/PTFE	DN40	
200TE	white - open laterally	EPDM/PTFE	DN50	
250TE	white - open laterally	EPDM/PTFE	DN65	
300TE	white - open laterally	EPDM/PTFE	DN80	
400TE	white - open laterally	EPDM/PTFE	DN100	
050FEP	red - sheathed	FEP (Silicone core)	DN15	
075FEP	red - sheathed	FEP (Silicone core)	DN20	
100FEP	red - sheathed	FEP (Silicone core)	DN25	
125FEP	red - sheathed	FEP (Silicone core)	DN32	
150FEP	red - sheathed	FEP (Silicone core)	DN40	
200FEP	red - sheathed	FEP (Silicone core)	DN50	
300FEP	red - sheathed	FEP (Silicone core)	DN80	
400FEP	red - sheathed	FEP (Silicone core)	DN100	



Kupplungsdichtung für Kamlok - EU1935/2004 für Lebensmittel

Gasket for Camlock - EU1935/2004 confirm

Joint Recouvert - Conforme à la norme EU1935/2004

Junta para acople Camlock - conforme EU1935/2004

Uszczelki do Camlock - EU1935/2004

Guarnizione per accoppiamento Camlock - Accreditemento EU1935/2004



Part-No.	Colour	Material	Norm	Dimension	Price
050E-EU1935	white	EPDM	FDA EU1935/2024	DN15	
075E-EU1935	white	EPDM	FDA EU1935/2024	DN20	
100E-EU1935	white	EPDM	FDA EU1935/2024	DN25	
125E-EU1935	white	EPDM	FDA EU1935/2024	DN32	
150E-EU1935	white	EPDM	FDA EU1935/2024	DN40	
200E-EU1935	white	EPDM	FDA EU1935/2024	DN50	
250E-EU1935	white	EPDM	FDA EU1935/2024	DN65	
300E-EU1935	white	EPDM	FDA EU1935/2024	DN80	
400E-EU1935	white	EPDM	FDA EU1935/2024	DN100	
050S-EU1935	red	Silicone	FDA EU1935/2024	DN15	
075S-EU1935	red	Silicone	FDA EU1935/2024	DN20	
100S-EU1935	red	Silicone	FDA EU1935/2024	DN25	
125S-EU1935	red	Silicone	FDA EU1935/2024	DN32	
150S-EU1935	red	Silicone	FDA EU1935/2024	DN40	
200S-EU1935	red	Silicone	FDA EU1935/2024	DN50	
250S-EU1935	red	Silicone	FDA EU1935/2024	DN65	
300S-EU1935	red	Silicone	FDA EU1935/2024	DN80	
400S-EU1935	red	Silicone	FDA EU1935/2024	DN100	

Dichtung für Guillemín Kupplung - EU1935/2004 für Lebensmittel

Gasket for Guillemín - EU1935/2004 confirm

Joint pour raccord Guillemín - EU1935/2004

Junta Guillemín EU1935/2004

Uszczelki do Złącze Guillemín EU1935/2004

Guarnizione Guillemín EU1935/2004

Part-No.	Colour	Material	Norm	Dimension	Price
CGE040-EU1935	white	EPDM	FDA EU1935/2024	DN40	
CGE050-EU1935	white	EPDM	FDA EU1935/2024	DN50	
CGE065-EU1935	white	EPDM	FDA EU1935/2024	DN65	
CGE080-EU1935	white	EPDM	FDA EU1935/2024	DN80	
CGE100-EU1935	white	EPDM	FDA EU1935/2024	DN100	
CGN040-EU1935	white	NBR	FDA EU1935/2024	DN40	
CGN050-EU1935	white	NBR	FDA EU1935/2024	DN50	
CGN065-EU1935	white	NBR	FDA EU1935/2024	DN65	
CGN080-EU1935	white	NBR	FDA EU1935/2024	DN80	
CGN100-EU1935	white	NBR	FDA EU1935/2024	DN100	
CGS040-EU1935	white	Silicone	FDA EU1935/2024	DN40	
CGS050-EU1935	white	Silicone	FDA EU1935/2024	DN50	
CGS065-EU1935	white	Silicone	FDA EU1935/2024	DN65	
CGS080-EU1935	white	Silicone	FDA EU1935/2024	DN80	
CGS100-EU1935	white	Silicone	FDA EU1935/2024	DN100	



Dichtung für Guillemin Kupplung

Guillemin gasket

Joint pour raccord Guillemin

Junta Guillemin

Uszczelki do Złącze Guillemin

Guarnizione Guillemin



Part-No.	Colour	Material	Dimension	Price
CGP020	White	PTFE	DN20	
CGP025	White	PTFE	DN25	
CGP032	White	PTFE	DN32	
CGP040	White	PTFE	DN40	
CGP050	White	PTFE	DN50	
CGP065	White	PTFE	DN65	
CGP080	White	PTFE	DN80	
CGP100	White	PTFE	DN100	
CGV020	Black	FKM	DN20	
CGV025	Black	FKM	DN25	
CGV032	Black	FKM	DN40	
CGV040	Black	FKM	DN40	
CGV050	Black	FKM	DN50	
CGV065	Black	FKM	DN65	
CGV080	Black	FKM	DN80	
CGV100	Black	FKM	DN100	
CGE020	White	EPDM	DN20	
CGE025	White	EPDM	DN25	
CGE032	White	EPDM	DN32	
CGE040	White	EPDM	DN40	
CGE050	White	EPDM	DN50	
CGE065	White	EPDM	DN65	
CGE080	White	EPDM	DN80	
CGE100	White	EPDM	DN100	

Dichtung für Guillemin Kupplung

Guillemin gasket

Joint pour raccord Guillemin

Junta Guillemin

Uszczelki do Złącze Guillemin

Guarnizione Guillemin

Part-No.	Colour	Material	Dimension	Price
CGN020	Black	NBR	DN20	
CGN025	Black	NBR	DN25	
CGN032	Black	NBR	DN32	
CGN040	Black	NBR	DN40	
CGN050	Black	NBR	DN50	
CGN065	Black	NBR	DN65	
CGN080	Black	NBR	DN80	
CGN080SW*	Black	NBR	DN80	
CGN100	Black	NBR	DN100	
CGN100SW*	Black	NBR	DN100	
CGN040-W	White	NBR	DN40	
CGN050-W	White	NBR	DN50	
CGN065-W	White	NBR	DN65	
CGN080-W	White	NBR	DN80	
CGN080SW-W*	White	NBR	DN80	
CGN100-W	White	NBR	DN100	
CGN100SW-W*	White	NBR	DN100	
CGN125-W	White	NBR	DN125	
CGN150-W	White	NBR	DN150	



*nur für die drehbaren Alu Kupplungen

*only for aluminum swivel Couplings



Dichtung für DSP Kupplung

DSP gasket
 Joint pour raccord DSP
 Junta DSP
 Uszczelki do Złącze DSP
 Guarnizione DSP

Part-No.	Colour	Material	Dimension	Price
DSPJ040	black	NBR	DN40	
DSPJ065	black	NBR	DN65	
DSPJ100	black	NBR	DN100	



Ersatzdichtung für «EUROPEAN» und «US-Ausführung»

Claw coupling AMERICAN and EUROPEAN type - gasket
 Raccord type Américain DIN3489 - Joint
 Racor tipo USA Junta
 Złącze kłowe «Typ Amerykański» Uszczelka
 Raccordo tipo USA - Guarnizioni



Part-No.	Colour	Material	Dimension	Price
AKG	Black	NBR	Universal	
AKG-V	Green	FKM	Universal	



Ersatzdichtung für Sandstrahlarmatur

Sandblast coupling - gasket
 Joint pour raccord de sablage
 Junta para acople chorro de arena
 Uszczelka do złączy do piaskowania
 Guarnizione per raccordo per sabbiatrice

Part-No.	Colour	Material	Dimension	Price
SABJ-N	Black	NBR	Universal	

Ersatzdichtung für Wasserschlaucharmaturen

Gasket for water hose fitting

Joint pour raccord d'eau

Racor para agua - Junta

Złącza kłowe do wody - Uszczelka

Raccordo per acqua - Guarnizioni



Part-No.	Colour	Material	Dimension	Price
EXG	Black	NBR	Universal	
EXG-VG	Green	FKM	Universal	

Barcelona Ersatzdichtungen

Barcelona gaskets

Joint pour raccord Barcelona

Junta para racor Barcelona

Uszczelka do złączy Barcelona

Guarnizione per raccordo Barcelona



Part-No.	Colour	Material	Dimension	Price
BACON25	black	NBR	DN25	
BACON45	black	NBR	DN45	
BACON70	black	NBR	DN70	

Dichtung für Storz - Saug & Druckdichtung

Storz gasket - suction and pressure gasket

Joint pour raccord Storz - joint d'aspiration et de pression

Junta para Storz - Junta de succión y presión

Uszczelki do Storz - Uszczelnienie ssące i ciśnieniowe

Guarnizione per Stortz - Tenuta in aspirazione e in pressione

NEW

Part-No.	Colour	Material	Dimension	Price
STJ31	Black	NBR	DN25(D)	
STJ44	Black	NBR	DN32	
STJ52	Black	NBR	DN38	
STJ66	Black	NBR	DN52(C)	
STJ81	Black	NBR	DN65	
STJ89	Black	NBR	DN75(B)	
STJ115	Black	NBR	DN100	
STJ133	Black	NBR	DN110(A)	
STJ148	Black	NBR	DN125	
STJ31B	White	NBR	DN25 (D)	
STJ44B	White	NBR	DN32	
STJ52B	White	NBR	DN38	
STJ66B	White	NBR	DN52(C)	
STJ81B	White	NBR	DN65	
STJ89B	White	NBR	DN75(B)	
STJ115B	White	NBR	DN100	
STJ133B	White	NBR	DN110(A)	
STJ148B	White	NBR	DN125	
STJ160B	White	NBR	DN150	

Dichtung für Storz - Saug & Druckdichtung

Storz gasket - suction and pressure gasket

Joint pour raccord Storz - joint d'aspiration et de pression

Junta para Storz - Junta de succión y presión

Uszczelki do Storz - Uszczelnienie ssące i ciśnieniowe

Guarnizione per Stortz - Tenuta in aspirazione e in pressione

NEW

Part-No.	Colour	Material	Dimension	Price
STJ31V	Black	FKM	DN25(D)	
STJ44V	Black	FKM	DN32	
STJ52V	Black	FKM	DN38	
STJ66V	Black	FKM	DN52(C)	
STJ81V	Black	FKM	DN65	
STJ89V	Black	FKM	DN75(B)	
STJ115V	Black	FKM	DN100	
STJ133V	Black	FKM	DN110(A)	
STJ31V-G	Green	FKM	DN25(D)	
STJ44V-G	Green	FKM	DN32	
STJ52V-G	Green	FKM	DN38	
STJ66V-G	Green	FKM	DN52(C)	
STJ81V-G	Green	FKM	DN65	
STJ89V-G	Green	FKM	DN75(B)	
STJ115V-G	Green	FKM	DN100	
STJ133V-G	Green	FKM	DN110(A)	
STJ31S-FDA	Transparent	Silicone -FDA	DN25(D)	
STJ44S-FDA	Transparent	Silicone -FDA	DN32	
STJ52S-FDA	Transparent	Silicone -FDA	DN38	
STJ66S-FDA	Transparent	Silicone -FDA	DN52(C)	
STJ81S-FDA	Transparent	Silicone -FDA	DN65	
STJ89S-FDA	Transparent	Silicone -FDA	DN75(B)	
STJ115S-FDA	Transparent	Silicone -FDA	DN100	
STJ133S-FDA	Transparent	Silicone -FDA	DN110(A)	



Dichtung für Storz - Druckdichtung

Storz gasket - pressure seal

Joint pour raccord Storz - joint de pression

Junta para Storz - sello de presión

Uszczelki do Storz - uszczelnienie ciśnieniowe

Guarnizione per Storz - tenuta a pressione

NEW

Part-No.	Colour	Material	Dimension	Price
STJ31-O	Black	NBR	DN25(D)	
STJ44-O	Black	NBR	DN32	
STJ52-O	Black	NBR	DN38	
STJ66-O	Black	NBR	DN52(C)	
STJ81-O	Black	NBR	DN65	
STJ89-O	Black	NBR	DN75(B)	
STJ115-O	Black	NBR	DN100	
STJ133-O	Black	NBR	DN110(A)	
STJ148-O	Black	NBR	DN125	
STJ31B-O	White	NBR	DN25 (D)	
STJ44B-O	White	NBR	DN32	
STJ52B-O	White	NBR	DN38	
STJ66B-O	White	NBR	DN52(C)	
STJ81B-O	White	NBR	DN65	
STJ89B-O	White	NBR	DN75(B)	
STJ115B-O	White	NBR	DN100	
STJ133B-O	White	NBR	DN110(A)	
STJ148B-O	White	NBR	DN125	

Dichtung für Storz - Druckdichtung

Storz gasket - pressure seal

Joint pour raccord Storz - joint de pression

Junta para Storz - sello de presión

Uszczelki do Storz - uszczelnienie ciśnieniowe

Guarnizione per Storz - tenuta a pressione

NEW

Part-No.	Colour	Material	Dimension	Price
STJ31V-O	Black	FKM	DN25(D)	
STJ44V-O	Black	FKM	DN32	
STJ52V-O	Black	FKM	DN38	
STJ66V-O	Black	FKM	DN52(C)	
STJ81V-O	Black	FKM	DN65	
STJ89V-O	Black	FKM	DN75(B)	
STJ115V-O	Black	FKM	DN100	
STJ133V-O	Black	FKM	DN110(A)	
STJ44V-G-O	Green	FKM	DN32	
STJ52V-G-O	Green	FKM	DN38	
STJ66V-G-O	Green	FKM	DN52(C)	
STJ81V-G-O	Green	FKM	DN65	
STJ89V-G-O	Green	FKM	DN75(B)	
STJ115V-G-O	Green	FKM	DN100	
STJ133V-G-O	Green	FKM	DN110(A)	
STJ31S-FDA-O	Transparent	Silicone -FDA	DN25(D)	
STJ44S-FDA-O	Transparent	Silicone -FDA	DN32	
STJ52S-FDA-O	Transparent	Silicone -FDA	DN38	
STJ66S-FDA-O	Transparent	Silicone -FDA	DN52(C)	
STJ81S-FDA-O	Transparent	Silicone -FDA	DN65	
STJ89S-FDA-O	Transparent	Silicone -FDA	DN75(B)	
STJ115S-FDA-O	Transparent	Silicone -FDA	DN100	
STJ133S-FDA-O	Transparent	Silicone -FDA	DN110(A)	



Dichtung für IBC Kupplung

Gasket for IBC couplings
 Joint recouvert pour IB
 Junta para IBC
 Uszczelki do IBC
 Guarnizione per accoppiamento IBC



Part-No.	Colour	Material	Confirm	Dimension	Price
IBCJ60	White	PE		S60	
IBCJ60E-EU1935	White	EPDM	EU1935	S60	
IBCJ60B-EU1935	White	NBR	EU1935	S60	
IBCJ60S-EU1935	Transparent	Silicone	EU1935	S60	

Dichtung für Composite Armaturen

Gaskets for Composite couplings
 Joint pour raccord composite
 Juntas para acoplamientos composite
 Uszczelki do Złącza węzła kompozytowego
 Guarnizione per composite



Part-No.	for Helics	Colour	Material	Dimension	Price
JH150	1	Black	NBR	DN38	
JH200	1	Black	NBR	DN50	
JH250	1	Black	NBR	DN65	
JH300	1	Black	NBR	DN80	
JH400	1	Black	NBR	DN100	
JV150	1	Brown	FKM	DN38	
JV200	1	Brown	FKM	DN50	
JV250	1	Brown	FKM	DN65	
JV300	1	Brown	FKM	DN80	
JV400	1	Brown	FKM	DN100	

Dichtungen für «CLAMP» Kupplung - FDA - EU1935/2004

Gaskets for Clamp coupling - FDA - EU1935/2004 Confim

Joint pour raccord CLAMP - FDA - Conforme à la norme EU1935/2004

Juntas Clamp - FDA - acreditación EU1935/2004

«Clamp» Uszczelki - FDA - EU1935/2004 A

Guarnizione per accoppiamento Clamp - FDA - Accreditemento EU1935/2004

Part-No.	Colour	Material	Norm	DN	Disk	Price
CLGNW106	White	NBR	FDA EU1935/2024	25	50,5	
CLGNW156	White	NBR	FDA EU1935/2024	40	50.5	
CLGNW206	White	NBR	FDA EU1935/2024	50	64	
CLGNW256	White	NBR	FDA EU1935/2024	65	91	
CLGNW306	White	NBR	FDA EU1935/2024	80	106	
CLGEP051	Black	EPDM	FDA EU1935/2024	15	34	
CLGEP076	Black	EPDM	FDA EU1935/2024	20	34	
CLGEP106	Black	EPDM	FDA EU1935/2024	25	50,5	
CLGEP125	Black	EPDM	FDA EU1935/2024	32	50,5	
CLGEP156	Black	EPDM	FDA EU1935/2024	40	50,5	
CLGEP206	Black	EPDM	FDA EU1935/2024	50	64	
CLGEP256	Black	EPDM	FDA EU1935/2024	65	91	
CLGEP306	Black	EPDM	FDA EU1935/2024	80	106	
CLGEP406	Black	EPDM	FDA EU1935/2024	100	119	
CLGS051	Transparent	Silicone	FDA EU1935/2024	15	34	
CLGS076	Transparent	Silicone	FDA EU1935/2024	20	34	
CLGS106	Transparent	Silicone	FDA EU1935/2024	25	50,5	
CLGS125	Transparent	Silicone	FDA EU1935/2024	32	50,5	
CLGS156	Transparent	Silicone	FDA EU1935/2024	40	50,5	
CLGS206	Transparent	Silicone	FDA EU1935/2024	50	64	
CLGS256	Transparent	Silicone	FDA EU1935/2024	65	91	
CLGS306	Transparent	Silicone	FDA EU1935/2024	80	106	
CLGS406	Transparent	Silicone	FDA EU1935/2024	100	119	



NEW

Dichtungen für «CLAMP» Kupplung - FDA - EU1935/2004

Gaskets for Clamp coupling - FDA - EU1935/2004 Confim

Joint pour raccord CLAMP - FDA - Conforme à la norme EU1935/2004

Juntas Clamp - FDA - acreditación EU1935/2004

«Clamp» Uszczelki - FDA - FD EU1935/2004 A

Guarnizione per accoppiamento Clamp - FDA - Accreditemento EU1935/2004

**NEW**

Part-No.	Colour	Material	Norm	DN	Disk	Price
CLGP051	White	PTFE	FDA EU1935/2024	15	34	
CLGP076	White	PTFE	FDA EU1935/2024	20	34	
CLGP106	White	PTFE	FDA EU1935/2024	25	50,5	
CLGP125	White	PTFE	FDA EU1935/2024	32	50,5	
CLGP156	White	PTFE	FDA EU1935/2024	40	50,5	
CLGP206	White	PTFE	FDA EU1935/2024	50	64	
CLGP256	White	PTFE	FDA EU1935/2024	65	91	
CLGP306	White	PTFE	FDA EU1935/2024	80	106	
CLGP406	White	PTFE	FDA EU1935/2024	100	119	

Dichtungsplatte für Milchrohr Kappe nach DIN11851

DIN11851 hygenic gaskets

Joint pour bouchon raccord DIN11851

Juntas tapón DIN11851

Uszczelka zaślepki DIN11851

Guarnizioni igieniche DIN11851 Tappo



Part-No.	Colour	Material	Norm	Dimension	Price
DINC20JS	White	Silicone	FDA	DN20	
DINC25JS	White	Silicone	FDA	DN25	
DINC32JS	White	Silicone	FDA	DN32	
DINC40JS	White	Silicone	FDA	DN40	
DINC50JS	White	Silicone	FDA	DN50	
DINC65JS	White	Silicone	FDA	DN65	
DINC80JS	White	Silicone	FDA	DN80	
DINC100JS	White	Silicone	FDA	DN100	

Dichtung für Milchrohrverschraubung - EU1935/2004

DIN hygenic gaskets - EU1935/2004 confim

Joint semi-torique pour raccord DIN - Conforme à la norme EU1935/2004

Juntas higiénicas DIN - acreditación EU1935/2004

Uszczelki do złączy mleczarskich- FD EU1935/2004 A

Guarnizioni igieniche DIN - Accreditemento EU1935/2004



Part-No.	Colour	Material	Norm	Dimension	Price
DINJP020	White	PTFE	FDA EU1935/2024	DN20	
DINJP025	White	PTFE	FDA EU1935/2024	DN25	
DINJP032	White	PTFE	FDA EU1935/2024	DN32	
DINJP040	White	PTFE	FDA EU1935/2024	DN40	
DINJP050	White	PTFE	FDA EU1935/2024	DN50	
DINJP065	White	PTFE	FDA EU1935/2024	DN65	
DINJP080	White	PTFE	FDA EU1935/2024	DN80	
DINJP100	White	PTFE	FDA EU1935/2024	DN100	

Dichtung für Milchrohrverschraubung - EU1935/2004

DIN hygenic Gaskets - EU1935/2004 confim

Joint semi-torique pour raccord DIN - Conforme à la norme EU1935/2004

Juntas higiénicas DIN - acreditación EU1935/2004

Uszczelki do złączy mleczarskich- FD EU1935/2004 A

Guarnizioni igieniche DIN - Accreditemento EU1935/2004



FITTINGS & ZUBEHÖR

Part-No.	Colour	Material	Norm	Dimension	Price
DINJE020	Transparent	Silicone	FDA EU1935/2024	DN20	
DINJE025	Transparent	Silicone	FDA EU1935/2024	DN25	
DINJE032	Transparent	Silicone	FDA EU1935/2024	DN32	
DINJE040	Transparent	Silicone	FDA EU1935/2024	DN40	
DINJE050	Transparent	Silicone	FDA EU1935/2024	DN50	
DINJE065	Transparent	Silicone	FDA EU1935/2024	DN65	
DINJE080	Transparent	Silicone	FDA EU1935/2024	DN80	
DINJE100	Transparent	Silicone	FDA EU1935/2024	DN100	
DINJN020	Blue	NBR	FDA EU1935/2024	DN20	
DINJN025	Blue	NBR	FDA EU1935/2024	DN25	
DINJN032	Blue	NBR	FDA EU1935/2024	DN32	
DINJN040	Blue	NBR	FDA EU1935/2024	DN40	
DINJN050	Blue	NBR	FDA EU1935/2024	DN50	
DINJN065	Blue	NBR	FDA EU1935/2024	DN65	
DINJN080	Blue	NBR	FDA EU1935/2024	DN80	
DINJN100	Blue	NBR	FDA EU1935/2024	DN100	
DINJEP020	Black	EPDM	FDA EU1935/2024	DN20	
DINJEP025	Black	EPDM	FDA EU1935/2024	DN25	
DINJEP032	Black	EPDM	FDA EU1935/2024	DN32	
DINJEP040	Black	EPDM	FDA EU1935/2024	DN40	
DINJEP050	Black	EPDM	FDA EU1935/2024	DN50	
DINJEP065	Black	EPDM	FDA EU1935/2024	DN65	
DINJEP080	Black	EPDM	FDA EU1935/2024	DN80	
DINJEP100	Black	EPDM	FDA EU1935/2024	DN100	

Dichtung für SMS Dichtung - FDA

SMS gasket - FDA

Joint à lèvres SMS - FDA

Junta SMS - FDA

SMS Uszczelka - FDA Guarnizioni SMS

Guarnizioni SMS - FDA



Part-No.	Colour	Material	Norm	Dimension	Price
SMSJ25	White	EPDM	FDA	DN25	
SMSJ32	White	EPDM	FDA	DN32	
SMSJ38	White	EPDM	FDA	DN38	
SMSJ50	White	EPDM	FDA	DN50	
SMSJ63	White	EPDM	FDA	DN63	
SMSJ80	White	EPDM	FDA	DN76	
SMSJ100	White	EPDM	FDA	DN104	



Dichtung für Macon Kupplung

Macon gasket
 Joint à lèvres Macon
 Junta Macon
 Macon Uszczelka
 Guarnizione Macon

Part-No.	Colour	Material	Dimension	Price
MACJ38	White	EPDM	DN38	
MACJ50	White	EPDM	DN50	
MACJ70	White	EPDM	DN70	

Dichtung für Macon - EU1935/2004

Macon gasket - EU1935/2004 confim
 Joint à lèvres Macon - Conforme à la norme EU1935/2004
 Junta Macon - acreditación EU1935/2004
 Macon Uszczelka - EU1935/2004
 Guarnizione Macon - Accreditemento EU1935/2004

NEW

Part-No.	Colour	Material	Dimension	Price
MACJE038-EU1935	White	EPDM	FDA EU1935/2024 DN38	
MACJE050-EU1935	White	EPDM	FDA EU1935/2024 DN50	
MACJE070-EU1935	White	EPDM	FDA EU1935/2024 DN70	
MACJN038-EU1935	White	NBR	FDA EU1935/2024 DN38	
MACJN050-EU1935	White	NBR	FDA EU1935/2024 DN50	
MACJN070-EU1935	White	NBR	FDA EU1935/2024 DN70	
MACJS038-EU1935	Transparent	Silicone	FDA EU1935/2024 DN38	
MACJS050-EU1935	Transparent	Silicone	FDA EU1935/2024 DN50	
MACJS070-EU1935	Transparent	Silicone	FDA EU1935/2024 DN70	

Gewindedichtungen für Armaturen nach EN 14420

Thread gasket for EN 14420 couplings

Joint de filetage EN 14420

Junta para rosca EN 14420

Uszczelki gwintowane do zgodnie EN 14420

Guarnizione per filettatura EN 14420

Part-No.	Colour	Material	Dimension	Price
SFPU13	Black	PU	DN13	
SFPU19	Black	PU	DN19	
SFPU25	Black	PU	DN25	
SFPU32	Black	PU	DN32	
SFPU38	Black	PU	DN38	
SFPU50	Black	PU	DN50	
SFPU65	Black	PU	DN65	
SFPU80	Black	PU	DN75	
SFPU100	Black	PU	DN100	
SFPU13B	Blue	PU	DN13	
SFPU19B	Blue	PU	DN19	
SFPU25B	Blue	PU	DN25	
SFPU32B	Blue	PU	DN32	
SFPU38B	Blue	PU	DN38	
SFPU50B	Blue	PU	DN50	
SFPU65B	Blue	PU	DN65	
SFPU80B	Blue	PU	DN75	
SFPU100B	Blue	PU	DN100	



Gewindedichtungen für Armaturen nach EN 14420

Thread gasket for EN 14420 couplings

Joint de filetage EN 14420

Junta para rosca EN 14420

Uszczelki gwintowane do zgodnie EN 14420

Guarnizione per filettatura EN 14420



Part-No.	Colour	Material	Dimension	Price
SFPU13T	Transparent	PU	DN13	
SFPU19T	Transparent	PU	DN19	
SFPU25T	Transparent	PU	DN25	
SFPU32T	Transparent	PU	DN32	
SFPU38T	Transparent	PU	DN38	
SFPU50T	Transparent	PU	DN50	
SFPU65T	Transparent	PU	DN65	
SFPU80T	Transparent	PU	DN75	
SFPU100T	Transparent	PU	DN100	
0.75TWTFG	White	PTFE GF reinforced	DN19	
1TWTFG	White	PTFE GF reinforced	DN25	
1.25TWTFG	White	PTFE GF reinforced	DN32	
1.5TWTFG	White	PTFE GF reinforced	DN38	
2TWTFG	White	PTFE GF reinforced	DN50	
2.5TWTFG	White	PTFE GF reinforced	DN65	
3TWTFG	White	PTFE GF reinforced	DN75	
4TWTFG	White	PTFE GF reinforced	DN100	
2TWVI	Black	FKM	DN50	
3TWVI	Black	FKM	DN75	
4TWVI	Black	FKM	DN100	



Gewindedichtungen für Armaturen nach EN 14420

Thread gasket for EN 14420 couplings

Joint de filetage EN 14420

Junta para rosca EN 14420

Uszczelki gwintowane do zgodnie EN 14420

Guarnizione per filettatura EN 14420

Part-No.	Colour	Material	Dimension	Price
SFN19	Black	NBR	DN19	
SFN25	Black	NBR	DN25	
SFN32	Black	NBR	DN32	
SFN38	Black	NBR	DN38	
SFN50	Black	NBR	DN50	
SFN65	Black	NBR	DN64	
SFN80	Black	NBR	DN75	
SFN100	Black	NBR	DN100	
SFN125	Black	NBR	DN125	
SFN19-W	White	NBR	DN19	
SFN25-W	White	NBR	DN25	
SFN32-W	White	NBR	DN32	
SFN38-W	White	NBR	DN38	
SFN50-W	White	NBR	DN50	
SFN65-W	White	NBR	DN64	
SFN80-W	White	NBR	DN75	
SFN100-W	White	NBR	DN100	
SFN125-W	White	NBR	DN125	



Gewindedichtungen für Armaturen nach EN 14420 - für Lebensmittel

Thread gasket for EN 14420 couplings

Joint de filetage EN 14420 - pour les produits alimentaires

Junta para rosca EN 14420 - alimentaria

Uszczelki gwintowane do zgodnie EN 14420 - dla żywności

Guarnizione per filettatura N 14420 - per il cibo



Part-No.	Colour	Material	Norm	Dimension	Price
SFE13-FDA	White	EPDM	FDA EU1935/2024	DN13	
SFE19-FDA	White	EPDM	FDA EU1935/2024	DN19	
SFE25-FDA	White	EPDM	FDA EU1935/2024	DN25	
SFE32-FDA	White	EPDM	FDA EU1935/2024	DN32	
SFE38-FDA	White	EPDM	FDA EU1935/2024	DN38	
SFE50-FDA	White	EPDM	FDA EU1935/2024	DN50	
SFE65-FDA	White	EPDM	FDA EU1935/2024	DN65	
SFE80-FDA	White	EPDM	FDA EU1935/2024	DN75	
SFE100-FDA	White	EPDM	FDA EU1935/2024	DN100	
SFE125-FDA	White	EPDM	FDA EU1935/2024	DN125	
SFE150-FDA	White	EPDM	FDA EU1935/2024	DN150	
SFN13-EU1935	White	NBR	FDA EU1935/2024	DN13	
SFN19-EU1935	White	NBR	FDA EU1935/2024	DN19	
SFN25-EU1935	White	NBR	FDA EU1935/2024	DN25	
SFN32-EU1935	White	NBR	FDA EU1935/2024	DN32	
SFN38-EU1935	White	NBR	FDA EU1935/2024	DN38	
SFN50-EU1935	White	NBR	FDA EU1935/2024	DN50	
SFN65-EU1935	White	NBR	FDA EU1935/2024	DN65	
SFN80-EU1935	White	NBR	FDA EU1935/2024	DN75	
SFN100-EU1935	White	NBR	FDA EU1935/2024	DN100	
SFN125-EU1935	White	NBR	FDA EU1935/2024	DN125	
SFN150-EU1935	White	NBR	FDA EU1935/2024	DN150	

Gewindedichtungen für Armaturen nach EN 14420 - für Lebensmittel

Thread gasket for EN 14420 couplings

Joint de filetage EN 14420 - pour les produits alimentaires

Junta para rosca EN 14420 - alimentaria

Uszczelki gwintowane do zgodnie EN 14420 - dla żywności

Guarnizione per filettatura EN 14420 - per il cibo

Part-No.	Colour	Material	Norm	Dimension	Price
SFS13-EU1935	Transparent	Silicone	FDA EU1935/2024	DN13	
SFS19-EU1935	Transparent	Silicone	FDA EU1935/2024	DN19	
SFS25-EU1935	Transparent	Silicone	FDA EU1935/2024	DN25	
SFS32-EU1935	Transparent	Silicone	FDA EU1935/2024	DN32	
SFS38-EU1935	Transparent	Silicone	FDA EU1935/2024	DN38	
SFS50-EU1935	Transparent	Silicone	FDA EU1935/2024	DN50	
SFS65-EU1935	Transparent	Silicone	FDA EU1935/2024	DN65	
SFS80-EU1935	Transparent	Silicone	FDA EU1935/2024	DN75	
SFS100-EU1935	Transparent	Silicone	FDA EU1935/2024	DN100	
SFS125-EU1935	Transparent	Silicone	FDA EU1935/2024	DN125	
SFS150-EU1935	Transparent	Silicone	FDA EU1935/2024	DN150	
SFPV13-EU1935	White	PTFE Virginal	FDA EU1935/2024	DN13	
SFPV19-EU1935	White	PTFE Virginal	FDA EU1935/2024	DN19	
SFPV25-EU1935	White	PTFE Virginal	FDA EU1935/2024	DN25	
SFPV32-EU1935	White	PTFE Virginal	FDA EU1935/2024	DN32	
SFPV38-EU1935	White	PTFE Virginal	FDA EU1935/2024	DN38	
SFPV50-EU1935	White	PTFE Virginal	FDA EU1935/2024	DN50	
SFPV65-EU1935	White	PTFE Virginal	FDA EU1935/2024	DN65	
SFPV80-EU1935	White	PTFE Virginal	FDA EU1935/2024	DN75	
SFPV100-EU1935	White	PTFE Virginal	FDA EU1935/2024	DN100	



NEW



Gewindedichtungen für Armaturen nach EN 14420 Dampfschlaucharmaturen

Thread gasket for EN 14420 couplings

Joint de filetage EN 14420

Junta para rosca Camlock EN 14420

Uszczelki gwintowane do zgodnie EN 14420

Guarnizione per filettatura EN 14420

Part-No.	Description	Material	Dimension	Price
FVJ50	Be careful when installing. Risk of breakage	Fiber Gasket	DN13	
FVJ75	Be careful when installing. Risk of breakage	Fiber Gasket	DN19	
FVJ100	Be careful when installing. Risk of breakage	Fiber Gasket	DN25	
FVJ125	Be careful when installing. Risk of breakage	Fiber Gasket	DN32	
FVJ150	Be careful when installing. Risk of breakage	Fiber Gasket	DN38	
FVJ200	Be careful when installing. Risk of breakage	Fiber Gasket	DN50	

«Whipcheck» Schlauchsicherungskabel

Whipcheck

Câble anti-fouet

Cable de seguridad para mangueras

«Whipcheck» Linka zabezpieczająca do węży

Cavo di sicurezza per tubi



Part-No.	Material	DN-Cable	Length	Tensile Strength	Price
WCB1	Steel	1/2" - 2"	500 mm	620 kg	
WCB2	Steel	3/4" - 2"	450 mm	620 kg	
WCA2	Steel	2" - 4"	900 mm	1150 kg	
CHAUSS815	Steel	8-15mm	687,5 mm	900 kg	
CHAUSS1525	Steel	15-25 mm	801,5 mm	1800 kg	
CHAUS2545	Steel	25-45 mm	878 mm	1800 kg	
CHAUSS3050	Steel	30-50 mm	898,5 mm	1800 kg	
CHAUSS6080	Steel	60-80 mm	975 mm	1800 kg	

PTFE Dichtband

PTFE tape

Bande PTFE

Cinta de PTFE

Taśma PTFE

Nastro di PTFE



Part-No.	Colour	Length	Thickness	Width	Density	Price
TB01-12M	Yellow	12m	0,1mm	12mm	100g/m ²	
TB02-10M	Blue	10m	0,1mm	12mm	40g/m ²	

Silikon Vulkanisierband

Silicone vulcanising tape
 Bande de vulcanisation en silicone
 Cinta vulcanizadora de silicona
 Silikonowa taśma wulkanizacyjna
 Nastro vulcanizzante in silicone



Part-No.	Colour	Length	Thickness	Width	Price
VB01-10M	Red	10m	0,5mm	25mm	
VB02-10M	Black	10m	0,5mm	25mm	

NEW

Schlauchschneidemesser

Hose cutting knife
 Couteau à couper les tuyaux
 Cuchillo para cortar mangueras
 Nóż do cięcia węży
 Coltello da taglio per tubi flessibili



NEW

Part-No.	Description	Price
CUTSSM	Cutting edge with sharp teeth wooden handle 315mm blade	



Metric Standard
Series
NBR-70
32 Size
419 pcs

O-Ring Service Kit (ORING419N) - Inhalt siehe Tabelle

O-ring service kit (ORING419N) - see table for contents

Kit de service O-Ring (ORING419N)- Voir tableau pour contenu

Kit de servicio de junta tórica (ORING419N) - ver tabla de contenido

Zestaw serwisowy O-ring (ORING419N) - patrz spis treści

Kit di servizio O-ring (ORING419N)- vedi tabella per il contenuto

No	IDxCS	PCS	No	IDxCS	PCS	No	IDxCS	PCS
R-01	3,0x1,5	20	R-12	18x2,5	14	R-23	30,0x3,5	10
R-02	4,4x2,0	20	R-13	19x2,5	13	R-24	31,0x3,5	10
R-03	5,0x2,0	18	R-14	21x2,5	14	R-25	33,0x3,5	10
R-04	7,0x1,5	23	R-15	22x2,5	13	R-26	34,5x3,5	10
R-05	10x1,5	23	R-16	18x3,5	10	R-27	36,0x3,5	10
R-06	13x1,5	23	R-17	20,0x3,5	10	R-28	38,0x3,5	10
R-07	10x2,5	14	R-18	22,0x3,5	10	R-29	41,0x3,5	10
R-08	11x2,5	13	R-19	23,5x3,5	10	R-30	44,0x3,5	10
R-09	13x2,5	14	R-20	25,0x3,5	10	R-31	47,0x3,5	10
R-10	14x2,5	13	R-21	26,5x3,5	10	R-32	50,0x3,5	10
R-11	16x2,5	14	R-22	28,0x3,5	10	Part-Nr:	ORING419N	



Zapfpistole mit Schlauch

Nozzle PP with hose

Pistolet de distribution PP avec tuyau

Boquerel de PP con manguera

Dysza PP z wężem

Pistola di riempimento in PP con tubo flessibile

Part-No.	Hose	WP	Side 1	Side 2	Price
NZS075IBCF60-2M	PVC black, 2 meter length	5 bar	white PP Noz- zle Outlet 3/4" in SS304	IBC S60X6 female thread, black	

10 bar Platzdruck

10 bar Burtst Pressure

Zapfpistole Polypropylen

Nozzle polypropylene

Pistolet de distribution PP

Boquerel de PP

Dysza PP

Pistola di riempimento in PP

Part-No.	Description	WP	Inlet	Outlet	Price
NZP100HTP075	(1) Black - PP outlet Medium: diesel, kerosene, no corrosive liquid	5 bar	3/4"	1"	
NZP100HTP100	(1) Black - PP outlet Medium: diesel, kerosene, no corrosive liquid	5 bar	1"	1"	
NZP100HTP075-W	(2) White - PP outlet Medium: diesel, gasoline, kerosene, AdBlue and other low corrosive liquids	5 bar	3/4"	1"	
NZP100HTP100-W	(2) White - PP outlet Medium: diesel, gasoline, kerosene, AdBlue and other low corrosive liquids	5 bar	1"	1"	
NZS075HTP075-W	(3) White - SS304 outlet Medium: diesel, gasoline, kerosene, AdBlue and other low corrosive liquids	5 bar	3/4"	3/4"	
NZS075HTP100-W	(3) White - SS304 outlet Medium: diesel, gasoline, kerosene, AdBlue and other low corrosive liquids	5 bar	1"	3/4"	
NZS075HTP075-B	(4) Blue - FSS304 outlet Medium: diesel, gasoline, kerosene, AdBlue and other low corrosive liquids	5 bar	3/4"	3/4"	
NZS075HTP075-R	(5) Red - SS304 outlet Medium: diesel, gasoline, kerosene, AdBlue and other low corrosive liquids	5 bar	3/4"	3/4"	

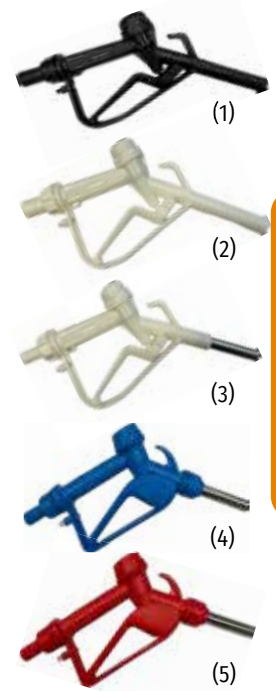

FITTINGS & ZUBEHÖR

10 bar Platzdruck

10 bar burst pressure

Schauglas mit beidseitigem BSPP Außengewinde, Material PC

Sight glass with both sides BSPP male thread, polycarbonate

Tube transparent Filetage mâle BSPP des deux côtés, polycarbonate

Mirilla con rosca macho BSPP en ambos lados, material PC

Tubo transparente rosca macho BSPP en ambos lados, policarbonato

Tubo trasparente con filetto maschio BSPP su entrambi i lati, policarbonato



Part-No.	Material	WP	Thread	Thread	Length	Price
SGBSPM200	Polycarbonate	10 bar	2"	2"	200mm	
SGBSPM300	Polycarbonate	10 bar	3"	3"	200mm	
SGBSPM400	Polycarbonate	10 bar	4"	4"	200mm	

PVC Gewindeschutzkappe

PVC thread protection cap

Capuchon de protection en PVC

Tapa protectora de PVC

Nakładka ochronna z PVC

Cappuccio di protezione in PVC

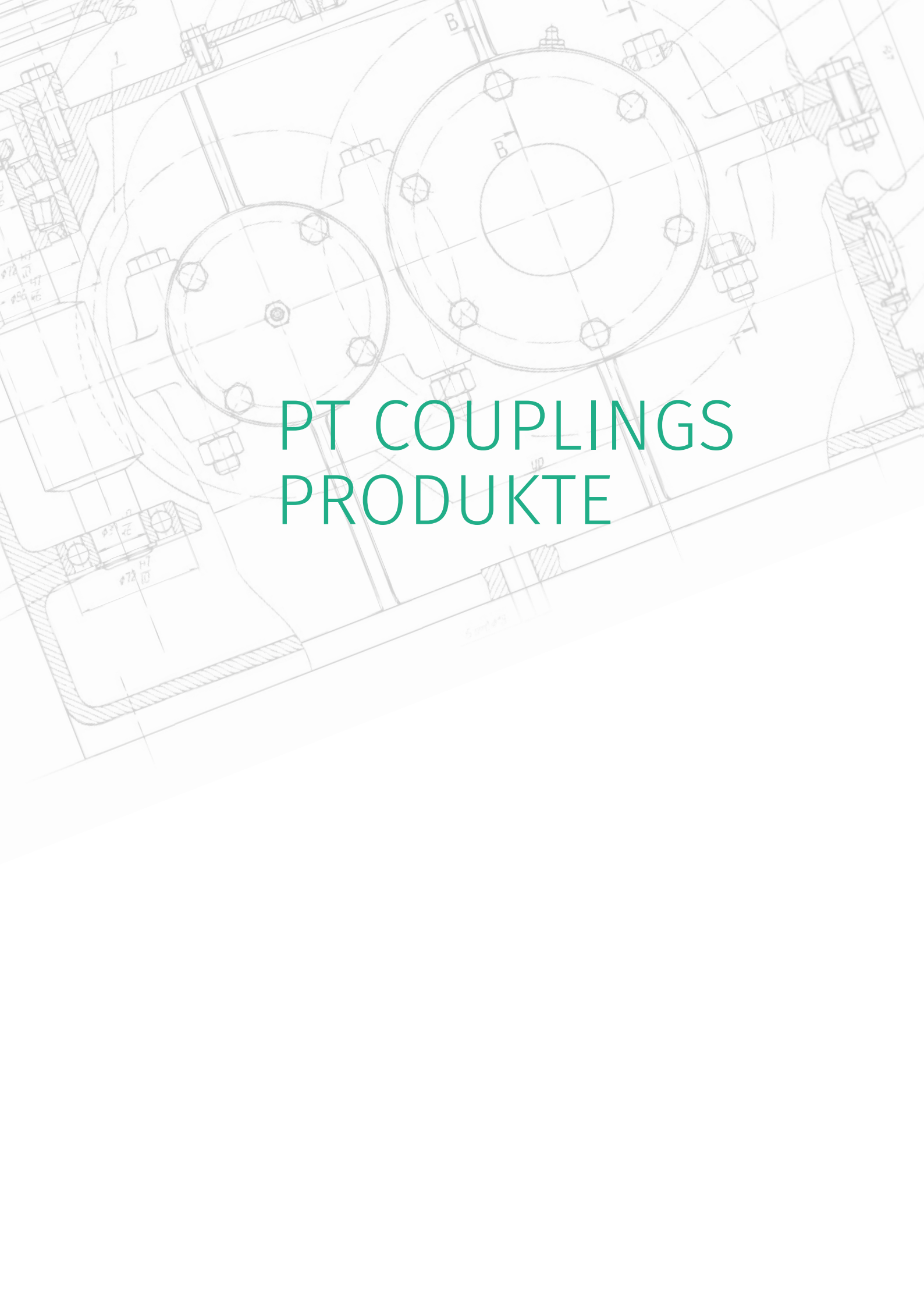

Part-No.	Colour	Material	Dimension	Price
CAP050PVC-B	Blue	PVC	1/2"	
CAP075PVC-B	Blue	PVC	3/4"	
CAP100PVC-B	Blue	PVC	1"	
CAP125PVC-B	Blue	PVC	1 1/4"	
CAP150PVC-B	Blue	PVC	1 1/2"	
CAP200PVC-B	Blue	PVC	2"	
CAP250PVC-B	Blue	PVC	2 1/2"	
CAP300PVC-B	Blue	PVC	3"	
CAP400PVC-B	Blue	PVC	4"	
CAP050PVC-T	Transparent	PVC	1/2"	
CAP075PVC-T	Transparent	PVC	3/4"	
CAP100PVC-T	Transparent	PVC	1"	
CAP125PVC-T	Transparent	PVC	1 1/4"	
CAP150PVC-T	Transparent	PVC	1 1/2"	
CAP200PVC-T	Transparent	PVC	2"	
CAP250PVC-T	Transparent	PVC	2 1/2"	
CAP300PVC-T	Transparent	PVC	3"	
CAP400PVC-T	Transparent	PVC	4"	

A detailed technical drawing of a mechanical coupling assembly, likely a PT coupling. The drawing shows two large circular flanges, one slightly larger than the other, connected by a central shaft. The flanges are secured with multiple bolts around their perimeters. The drawing includes various technical annotations such as 'B' for section lines, 'HT' for heat treatment, and 'HT 10' for a specific heat treatment process. The drawing is rendered in a light green color on a white background.

PT COUPLINGS PRODUKTE

Kamlok Kappen SAFETY BUMP® mit Arretierung

C&G Caps SAFETY BUMP® with locking device

Bouchon coupleur SAFETY BUMP® douille annelée

Tapones Camlock SAFETY BUMP® con cierre

Zaślepka wtyku SAFETY BUMP® z blokadą

Tappo femmina SAFETY BUMP® con chiusura



(1)



(1)



(1)

Part-No.	Material	Colour	PT Name	Size	Price
77021	Polypropylene	blue	20SBF	2"	
77023	Polypropylene	blue	30SBF	3"	
77025	Polypropylene	blue	40SBF	4"	
77004	Food Grade Poly	white	20SBF	2"	
77008	Food Grade Poly	white	30SBF	3"	
77012	Food Grade Poly	white	40SBF	4"	
77042	Aluminum		20SBF	2"	
77039	Aluminum		30SBF	3"	
77033	Aluminum		40SBF	4"	



Kamlok Stopfen SAFETY BUMP®

C&G Plug SAFETY BUMP®

Bouchon coupleur SAFETY BUMP®

Tapón Camlock hembra SAFETY BUMP®

Zaślepka wtyku SAFETY BUMP®

Tappo C&G SAFETY BUMP®



Part-No.	Material	Colour	PT Name	Size	Price
77020	Polypropylene	blue	20SBM	2"	
77022	Polypropylene	blue	30SBM	3"	
77024	Polypropylene	blue	40SBM	4"	
77002	Food Grade Poly	white	20SBM	2"	
77006	Food Grade Poly	white	30SBF	3"	
77010	Food Grade Poly	white	40SBF	4"	
77032	Aluminum		20SBM	2"	
77029	Aluminum		30SBM	3"	
77027	Aluminum		40SBM	4"	



(1) Zum einfacheren Händeln von Schlauchleitungen eignen sich die PT- Kamlock Kappen SAFETY BUMP® mit Arretierung (Kappe) und sehr stabilem Griff besonders gut. Passend für alle Standard Kamlock Kupplungen (Mutter/ Vatterteile) nach MIL und DIN.

(1) The PT Camlock SAFETY BUMP® with lock (cap) are designed to facilitate hose assemblies. They are suitable for all standard Camlock couplings (female/male parts) according to MIL and DIN. Suitable for all standard Camlock couplings (female / male parts) in accordance with MIL and DIN.



(2)

Kamlok Stopfen SAFETY BUMP®

C&G Plug SAFETY BUMP®
 Bouchon coupleur SAFETY BUMP®
 Tapón Camlock hembra SAFETY BUMP®
 Zaślepka wtyku SAFETY BUMP®
 Tappo C&G SAFETY BUMP®

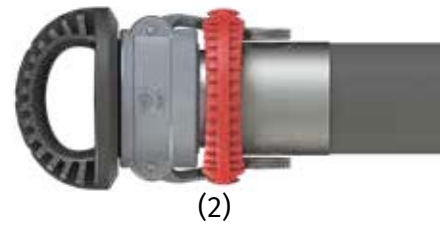

(2)

Part-No.	Material	Colour	PT Name	Size	Price
77041	Polypropylene	green	10SBL	1"	
77015	Polypropylene	blue	20SBL	2"	
77013	Polypropylene	red	30SBL	3"	
77014	Polypropylene	orange	40SBL	4"	

(2) PP Kamlock Sicherungsclip, einfache Sicherung für der Kamlock Hebel gegen ungewolltes öffnen. Geignet für Kamlock Kupplungen nach MIL und DIN. Nicht geeignet für MCC-Security/Self Lock Ausführungen. In vier Farben erhältlich zur besseren Unterscheidung der durchgeleiteten Medien.

(2) PP Camlock safety clips prevent unintentional opening. Suitable for Camlock couplings according to MIL and DIN. Not suitable for MCC-Security/Self Lock versions. Available in four colors for better differentiation of the media passed through.

Kamlock Hebelsicherung mit Klettverschluss



(3)

Camlock lever lock with hook & loop
 Sangle de fermeture avec velcro pour levier camlock
 Cinta velcro para asegurar manetas Kamlock
 Zamek dźwigniowy Kamlock z zapięciem na rzepy
 Chiusura a leva Kamlock con chiusura in velcro

Part-No.	Description	PT Name	Price
700001	Fits up to 1/2" couplings	CAM STRAP 112	
700002	Fits up to 3" couplings	CAM STRAP 218	
700004	Fits up to 4" couplings	CAM STRAP 236	

(3) Mit diesem einfachen breiten Klettverschluss ist eine simple Sicherung der Kamlock Hebel möglich. Verhindert ungewolltes Öffnen der Kupplung durch z.B. Vibrationen.

(3) This Camlock strap provides an easy protection for the Camlock arms since it prevents unintentional opening caused by e.g. vibrations

Kamlock Hebelsicherung Security Lock™

Kamlock lever lock Security Lock™

Serrure à levier camlock Security Lock™

Abrazadera para asegurar manetas Kamlock Security Lock™

Zamek dźwigniowy Kamlock Security Lock™

Chiusura a leva Kamlock Security Lock™



Part-No.	Material	PT Name	Size	Price
5007020	SS 316	SECURE-LOK™ 20	2"	
5007030	SS 316	SECURE-LOK™ 30	3"	
5007740	SS 316	SECURE-LOK™ 40	4"	

(4) Durch einfache Montage über die Kamlock Hebel zusammen mit einem Vorhängeschloss kann die Kamlock Kupplung nicht mehr geöffnet werden.

(4) By overstriking the SECURE LOK™ over the arms and closing the padlock, the coupling can no longer be opened.



A detailed technical drawing of a fire protection hose reel assembly. The drawing shows two circular reels mounted on a common frame. Each reel has a central hub and is surrounded by a series of bolts. The drawing includes various mechanical details, such as flanges, bolts, and seals, and is annotated with letters like 'B' and 'A' and numerical values like '100' and '120'. The drawing is rendered in a light blue color on a white background.

FEUERSCHUTZ- SCHLÄUCHE



Feuerschutzschlauch - EN45545 / DIN5510-2

Fire protection hose - EN45545 / DIN5510-2

Tuyau de protection contre l'incendie - EN45545 / DIN5510-2

Funda de protección contra incendios - EN45545 / DIN5510-2

Wąż przeciwpożarowy - EN45545 / DIN5510-2

Protezione antifiamma per tubi - EN45545 / DIN5510-2

Beschreibung: Silikonbeschichtetes
Fiberglas

Betriebstemperatur: max 260°C kurzfristig
1100°C

Norm: EN45545 und DIN5510-2
UL 1441







Rollenware: <= DN75 20m
> DN75 15m
(kein Anschnitt)

Description: Silicone coated fibreglas

Temperature: max 260°C short time
1100°C

Norm: EN45545 and DIN5510-2
UL 1441

Coil: <= DN75 20m
> DN75 15m
(no short lengths
available)

Part-No.	 mm	 mm	 bar	 mm	 %	 g/m	Price/m
SSCF-6	6	8,4					
SSCF-8	8	10,6					
SSCF-10	10	13,2					
SSCF-12	12	15,4					
SSCF-13	13	16,8					
SSCF-15	15	19,2					
SSCF-20	20	24,6					
SSCF-22	22	27					
SSCF-25	25	30,2					
SSCF-30	30	35,8					
SSCF-32	32	38					
SSCF-35	35	41,2					
SSCF-38	38	44,6					
SSCF-40	40	46,8					
SSCF-45	45	52					
SSCF-50	50	57,4					
SSCF-55	55	62,8					
SSCF-60	60	68					
SSCF-65	65	73,2					
SSCF-70	70	78,6					
SSCF-75	75	83,8					
SSCF-89	89	99					
SSCF-102	102	114					
SSCF-105	105	117					
SSCF-110	110	122					
SSCF-115	115	127					
SSCF-127	127	139					

Feuerschutzschlauch - EN45545 / DIN5510-2

Fire protection hose - EN45545 / DIN5510-2

Tuyau de protection contre l'incendie - EN45545 / DIN5510-2

Funda de protección contra incendios - EN45545 / DIN5510-2

Wąż przeciwpożarowy - EN45545 / DIN5510-2

Protezione antifiamma per tubi - EN45545 / DIN5510-2



NEW

Part-No.	 mm	 mm	 bar	 mm	 %	 g/m	Price/m
SSCF-10B	10	13,2					
SSCF-15B	15	19,2					
SSCF-20B	20	24,6					
SSCF-22B	22	27					
SSCF-25B	25	30,2					
SSCF-30B	30	35,8					
SSCF-32B	32	38					
SSCF-35B	35	41,2					
SSCF-40B	40	46,8					
SSCF-50B	50	57,4					

Beschreibung: Silikonbeschichtetes Fiberglas
 Betriebstemperatur: max 260°C kurzfristig 1100°C
 Norm: EN45545 und DIN5510-2 UL 1441
 Rollenware: 20m (kein Anschnitt)
 Description: Silicone coated fiberglas
 Temperature: max 260°C short time 1100°C
 Norm: EN45545 and DIN5510-2 UL 1441
 Coil: 20m (no short lengths available)



Feuerschutzschlauch mit Klettverschluss - EN45545 / DIN5510-2

Fire protection hose with hook & loop closure - EN45545 / DIN5510-2

Tuyau de protection contre l'incendie avec velcro - EN45545 / DIN5510-2

Manguera de protección contra incendios con velcro - EN45545 / DIN5510-2

Wąż przeciwpożarowy z zapięciem na rzep - EN45545 / DIN5510-2

Protezione antifiamma per tubi con velcro - EN45545 / DIN5510-2

Beschreibung: Silikonbeschichtetes Fiberglas mit Klettverschluss
Betriebstemperatur: max 260°C kurzfristig 1100°C
Norm: EN45545 und DIN5510-2 UL 1441
Rollenware: <= DN75 20m > DN75 10m (kein Anschnitt)
Description: Silicone coated fibreglas with loop closure
Temperature: max 260°C short time 1100°C
Norm: EN45545 and DIN5510-2 UL 1441
Coil: <= DN75 20m > DN75 10m (no short lengths available)

Part-No.	 mm	 mm	 bar	 mm	 %	 g/m	Price/m
SSCF-15-W	15	19,2					
SSCF-20-W	20	25					
SSCF-25-W	25	30,2					
SSCF-30-W	30	35,8					
SSCF-35-W	35	41,2					
SSCF-40-W	40	46,8					
SSCF-45-W	45	52					
SSCF-50-W	50	57,4					
SSCF-55-W	55	62,8					
SSCF-60-W	60	68					
SSCF-65-W	65	73,2					
SSCF-70-W	70	78,6					
SSCF-75-W	75	83,8					
SSCF-80-W	80	89					
SSCF-90-W	90	100					
SSCF-95-W	95	105					
SSCF-100-W	100	112					

FEUERSCHUTZSCHLÄUCHE



Silikon Vulkanisierband

Silicone vulcanising tape

Bande de vulcanisation en silicone

Cinta vulcanizadora de silicona

Silikonowa taśma wulkanizacyjna

Nastro vulcanizzante in silicone

NEW







Part-No.	Colour	Length	Thickness	Width	Price
VB01-10M	Red	10m	0,5mm	25mm	
VB02-10M	Black	10m	0,5mm	25mm	

Feuerschutzschlauch

Fire protection hose
 Tuyau de protection contre l'incendie
 Funda de protección contra incendios
 Wąż przeciwpożarowy
 Protezione antifiamma per tubi



NEW

Part-No.	 mm	 mm	 bar	 mm	 %	 g/m	Price/m
SSFF-10	10						
SSFF-12	12						
SSFF-15	15						
SSFF-20	20						
SSFF-25	25						







Beschreibung: Siliziumfaserschlauch
 Betriebstemperatur: max 1000°C kurzfristig
 1650°C
 Rollenware: 30m (kein Anschnitt)
 Description: Silica Fiber Sleeve, White
 Temperature: max 1000°C short time
 1650°C
 Coil: 30m (no short lengths available)

Nylon Schutzschlauch

Nylon protection sleeve
 Tube de protection en nylon
 Manguera protectora de nailon
 Nylonowy wąż ochronny
 Tubo protettivo in nylon



NEW

Part-No.	 mm	 mm	 bar	 mm	 %	 g/m	Price/m
SNPS-20	20						
SNPS-25	25						
SNPS-31	31						
SNPS-36	36						
SNPS-40	40						

Beschreibung: Nylon Schutzschlauch;
 Abriebfest, UV-Beständig
 und Staubdicht
 Betriebstemperatur: -40 °C bis +125 °C
 Rollenware: 50m (kein Anschnitt)
 Description: Nylon Protection Sleeve:
 Abrasion resistance, UV
 resistance and dust proof
 Temperature: -40 °C bis +125 °C
 Coil: 50m (no short lengths available)

FEUERSCHUTZSCHLÄUCHE









Scheuerschutzschlauch aus PP

PP Spiral guard hose
 Tuyau de protection
 Manguera de protección contra
 Wąż przeciwpożarowy z zapięciem
 Spirali per protezione tubi

NEW

Beschreibung: Scheuerschutzschlauch aus PP
 Betriebstemperatur: -50°C bis +100°C
 Rollenware: (kein Anschnitt)
 Description: PP Spiral guard hose
 Temperature: -50°C bis +100°C
 Coil: (no short lengths available)

Part-No.	 mm	 mm	 bar	 mm	 %	 g/m	Price/m
SSPG-10B	10						
SSPG-12B	12						
SSPG-14B	14						
SSPG-16B	16						
SSPG-20B	20						
SSPG-25B	25						
SSPG-32B	32						
SSPG-38B	38						
SSPG-50B	50						
SSPG-60B	60						
SSPG-72B	72						
SSPG-102B	102						
SSPG-114B	114						
SSPG-127B	127						







FEUERSCHUTZSCHLÄUCHE

Scheuerschutzschlauch aus PP

PP Spiral guard hose
 Tuyau de protection
 Manguera de protección contra
 Wąż przeciwpożarowy z zapięciem
 Spirali per protezione tubi



NEW

Part-No.	 mm	 mm	 bar	 mm	 %	 g/m	Price/m
SSPG-10Y	10						
SSPG-12Y	12						
SSPG-14Y	14						
SSPG-16Y	16						
SSPG-20Y	20						
SSPG-25Y	25						
SSPG-32Y	32						
SSPG-38Y	38						
SSPG-50Y	50						
SSPG-60Y	60						
SSPG-72Y	72						
SSPG-102Y	102						
SSPG-114Y	114						
SSPG-127Y	127						

Beschreibung: Scheuerschutzschlauch aus PP
 Betriebstemperatur: -50°C bis +100°C
 Rollenware: (kein Anschnitt)
 Description: PP Spiral guard hose
 Temperature: -50°C bis +100°C
 Coil: (no short lengths available)

WEITERE AUSFÜHRUNGEN

Feuer- und Hitzeschutzschläuche



FEUERSCHUTZSCHLÄUCHE

Im Zuge der Erweiterung des Programms Feuerschutzschläuche, werden wir weitere Gewebe-ausführungen mit den unterschiedlichsten beschichtungen in unser Programm mit aufnehmen (siehe unten).

Weitere Ausführungen auf Anfrage.



Nylon Sleeve Dual Guard

125°C
10mm - 95mm



Velcro Aluminium Coated Fiberglass Sleeve

260°C
15mm - 100mm



Nylon Sleeve

125°C
10mm - 95mm



Aluminium Coated Fiberglass Sleeve

260°C
5mm - 65mm



Firesleeve, Priority

260°C | 550°C
10mm - 50mm



Siresleeve, First

260°C | 550°C
6mm - 150mm



Zipper Firesleeve

260°C | 550°C
10mm - 305mm



Snap Button Firesleeve

260°C | 550°C
10mm - 305mm



Aramid Knitted Sleeve

350°C
6mm - 102mm



Electrical Firesleeve

260°C | 550°C
1,5mm - 30mm



Aramid Braided Sleeve

350°C
10mm - 80mm





MORE VERSIONS Fire and Heat Protection Hoses

FIRE AND HEATPROTECTION

As part of the expansion of the fire protection conduit programme, we will include further fabric versions with a wide variety of coatings in our product range (see below).

More versions on request.



Fiberglass Braided Sleeve

550C
10mm - 120mm



Fiberglass Knitted Sleeve

550C
13mm - 152mm



Expandable Fiberglass Sleeve

550°C
13mm - 89mm



Stainless Steel Fiber Knitted Sleeve

650°C
4mm - 120mm



Carbon Fiber Sleeve

650°C
8mm - 80mm



Basalt Fiber Knitted Sleeve

760°C
25mm - 152mm



Basalt Fiber Braided Sleeve

760°C
5mm - 120mm



Ceramic Fiber Sleeve

650°C / 1000°C
10mm - 150mm



Silica Fiber Sleeve

1000°C
3mm - 120mm



Heat Treated Fiberglass Sleeve

450°C
1mm - 30mm



Quartz Fiber Sleeve

1200°C
1mm - 63mm

WEITERE AUSFÜHRUNGEN

Feuer- und Hitzeschutzschläuche



BESCHICHTETES GEWEBE

Im Zuge der Erweiterung unseres Lieferprogramm Haben wir die Möglichkeit Ihnen auch einige Typen von Beschichtetem Gewebe anzubieten. Diese finden, konfektioniert, ihren Einsatz z.B: als Schweißservorhänge, Hitzeschutzplanen etc.

Weitere Informationen wie Gewicht, mögliche Beschichtungsstärken, Rollenlänge und Breite, auf Anfrage.



Silicone Coated Fiberglass Fabric

(Coating on both sides)

260°C

0.26mm - 2.0mm



Vermiculite Coated Silica Fiber Fabric

1000°C

0,7mm - 1,3mm



Aluminium Coated Fiberglass Fabric

260°C

0.2mm -2.0mm



Silicone Coated Fiberglass Fabric

(Coating on one side)

260°C | 550°C

0,5mm - 3,0mm



Fiberglass Fabric

550C

0.2mm -1.5mm



Texturized Fiberglass Fabric

550°C

0,8mm - 3,0mm



Stainless Steel Fiber Knitted Fabric

650°C

0.5mm - 0.75mm



Carbon Fiber Fabric

650°C

0,2mm - 0,9mm



Basalt Fiber Fabric

760°C

0.2mm - 0.9mm



Ceramic Fiber Fabric

650°C / 1000°C

1,5mm - 3,0mm



MORE VERSIONS

Fire and Heat Protection Hoses

COATED FABRICS

As part of the expansion of our product range, we are now also able to offer you some types of coated fabrics. These are used in ready-made form, e.g. as welding curtains, heat protection tarpaulins, etc.

Further information such as weight, roll length and width on request.t.



Silica Fiber Fabric

1000°C
0,26mm - 1,35mm



Quartz Fiber Fabric

1200°C
0,06mm - 0,5mm

WEITERE AUSFÜHRUNGEN

Feuer- und Hitzeschutzschläuche



ROPE PACKING

Gefertigt aus Beschichtetem Gewebe, finden diese Rundschnüre ihren Einsatz beim Abdichten Hochtemperaturbereich.

Weitere Infos auf Anfrage.



Silicone Coated Fiberglass Rope (Round)

260°C
4mm-50mm



Silicone Coated Fiberglass Rope (Square)

260°C
4x4mm-50x50mm



Fiberglass Rope (Round)

550°C
4mm -50mm



Fiberglass Rope (Square)

550°C
4x4mm-50x50mm



Ceramic Fiber Rope (Round)

650°C / 1000°C
3mm - 60mm



Ceramic Fiber Rope (Square)

650°C / 1000°C
4x4mm-50x50mm



Ceramic Fiber Rope (Round)

650°C / 1000°C
3mm - 60mm



Basalt Fiber Rope (Square)

760°C
4x4mm-50x50mm



MORE VERSIONS

Fire and Heat Protection Hoses

ROPPE PACKING

Made from coated fabric, these types round cords are used for sealing in high-temperature installation.

Further information on request.



Silica Fiber Rope (Round)

1000°C

3mm - 60mm



Silica Fiber Rope (Square)

1000°C

4x4mm-50x50mm



SILIKON-
SCHLÄUCHE



Silikonschlauch transparent - FDA

Silicone hose - transparent - FDA







Tuyau en silicone transparent - FDA

Manguera de silicona - transparente FDA

Wąż silikonowy przezroczysty - zgodny FDA

Tubo in silicone - FDA trasparente

Seele::	Silikon transparent PLATINVERNETZT
Betriebsdruck:	siehe Tabelle
Betriebstemperatur:	-50 bis +200°
Rollenlänge:	25 m (kein Anschnitt)
Shore:	70 Shore A +/-5
Zulassung	FDA; 2007/19/EC A+B+C: AS 2069, EC 1935/2004 (A, B, C, D1)
Tube:	silicone transparent PLATINUM CURED
Working Pressure:	see data sheet
Temperature:	-50 bis +200°
Coil Length:	25 m (no short lengths available)
Shore:	70 Shore A +/-5
Norm:	FDA; 2007/19/EC A+B+C: AS 2069, EC 1935/2004 (A, B, C, D1)

Part-No.	 mm	 mm	 bar	 mm	 %	 g/m	Price/m
SSI002X1	2	4	0,60			4,906	
SSI002X2	2	6	0,92			11,785	
SSI003X1,25	3	5,5	0,60			21,097	
SSI003X2	3	7	0,65			39,25	
SSI003X2,5	3	8	0,65			54	
SSI004X1	4	6	0,65			19,625	
SSI004X2	4	8	0,75			47,1	
SSI005X1	5	7	0,45			23,55	
SSI005X2	5	9	0,50			54,95	
SSI005X3	5	11	0,68			94,2	
SSI006X1	6	8	0,33			27,475	
SSI006X2	6	10	0,46			62,8	
SSI006X3	6	12	0,63			105,97	
SSI007X1	7	9	0,31			31,4	
SSI007X2	7	11	0,38			70,65	
SSI007X3	7	13	0,55			117,75	
SSI008X1	8	10	0,31			35,325	
SSI008X2	8	12	0,35			78,5	
SSI008X3	8	14	0,46			129,53	
SSI009X1	9	11	0,28			39,25	
SSI009X2	9	13	0,37			86,35	
SSI010X1	10	12	0,25			43,175	
SSI010X2	10	14	0,37			94,2	
SSI010X3	10	16	0,45			153,08	
SSI012X1,75	12	15,5	0,20			94,691	
SSI012X2	12	16	0,28			109,9	
SSI012X3	12	18	0,30			176,63	

Silikonschlauch transparent - FDA

Siliconehose - transparent - FDA

Tuyau en silicone transparent - FDA

Manguera de silicona - transparente FDA

Wąż silikonowy przezroczysty - zgodny FDA

Tubo in silicone - FDA trasparente



Part-No.	 mm	 mm	 bar	 mm	 %	 g/m	Price/m
SSI014X2	14	18	0,25			125,6	
SSI015X2	15	19	0,25			133,45	
SSI015X3	15	21	0,31			211,95	
SSI016X2	16	20	0,2			141,3	
SSI020X2	20	24	0,17			172,7	
SSI020X3,5	20	27	0,28			322,81	
SSI022X2	22	26	0,16			188,4	
SSI022X3	22	28	0,25			294,4	
SSI025X2	25	29	0,14			211,9	
SSI025X4	25	33	0,28			455,3	
SSI025X5	25	35	0,28			490,63	

Seele::	Silikon transparent PLATINVERNETZT
Betriebsdruck:	siehe Tabelle
Betriebstemperatur:	-50 bis +200°
Rollenlänge:	25 m (kein Anschnitt)
Shore:	70 Shore A +/-5
Zulassung	FDA; 2007/19/EC A+B+C; AS 2069, EC 1935/2004 (A, B, C, D1)
Tube::	silicone transparent PLATINUM CURED
Working Pressure:	see data sheet
Temperature:	-50 bis +200°
Coil Length:	25 m (no short lengths available)
Shore:	70 Shore A +/-5
Norm:	FDA; 2007/19/EC A+B+C; AS 2069, EC 1935/2004 (A, B, C, D1)

Silikonschlauch transparent - mit Einlage - FDA

Silicone Hose - transparent - braid reinforcement - FDA







Tuyau en silicone transparent avec filet intérieur

Manguera de silicona transparente con malla interior - FDA

Wąż silikonowy przezroczysty - z wkładką - zgodny FDA

Tubo in silicone trasparente con rete interna - FDA



Part-No.	 mm	 mm	 bar	 mm	 %	 g/m	Price
SSI004x2,5-G	4	9	9,0				
SSI005x3-G	5	11	9,0				
SSI006,3x3-G	6,3	12,3	9,0				
SSI009,5x3,25-G	9,5	16,5	7,0				
SSI012,7x4-G	12,7	20,7	5,5				
SSI016x4-G	16	24	4,0				
SSI019x4,5-G	19	28	3,5				
SSI025x5-G	25	35	3,0				
SSI032x5-G	32	42	2,0				
SSI038x5-G	38	48	2,0				

Seele:	Silikon transparent m. einlagigem Polyesterger- flecht PLATINVERNETZT
Druckträger:	text. Druckträger
Betriebsdruck:	siehe Tabelle
Betriebstemperatur:	- 40 °C - + 180°C
Rollenlänge:	25 m (kein Anschnitt)
Zulassung	FDA; 2007/19/EC A+B+C; AS 2069 EC 1935/2004 (A, B, C, D1)
Tube:	transparent silicone polyester braid reinfor- cement PLATINUM CURED
Working Pressure:	see data sheet
Temperature:	- 40 °C - + 180°C
Coil Length:	25 m (no short lengths available)
Norm:	FDA; 2007/19/EC A+B+C; AS 2069 EC 1935/2004 (A, B, C, D1)



Silikonschlauch transparent - mit Einlage - rot - FDA

Silicone hose - transparent - braid reinforcement - red - FDA
 Tuyau en silicone rouge avec un entoilage de polyester intercalé - FDA
 Manguera de silicona - Roja con entretela poliéster intercalada - FDA
 Wąż silikonowy czerwony - z wkładką - FDA
 Tubo in silicone - Rosso con fodera in poliesteri interlacciato - FDA

Seele: Silikon rot transparent m. einlagigem Polyestergerflecht
 PLATINVERNETZT
 Druckträger: text. Druckträger
 Betriebsdruck: siehe Tabelle
 Betriebstemperatur: - 40 °C - + 180°C
 Rollenlänge: 25 m (kein Anschnitt)
 Zulassung: FDA; 2007/19/EC A+B+C; AS 2069 EC 1935/2004 (A, B, C, D1)
 Tube: silicone red polyester braid reinforcement
 PLATINUM CURED
 Working Pressure: see data sheet
 Temperature: - 40 °C - + 180°C
 Coil Length: 25m (no short lengths available)
 Norm: FDA; 2007/19/EC A+B+C; AS 2069 EC 1935/2004 (A, B, C, D1)

Part-No.	mm	mm	bar	mm	%	g/m	Price/m
SSI006x3-GR	6	12	9,0				
SSI009x3-GR	9	15	7,0				
SSI012,7x4-GR	12,7	20,7	5,5				
SSI019x4-GR	19	27	3,5				
SSI025x5-GR	25	35	3,0				



Silikonschlauch mit Spirale gem. USP Class VI mit Einlage

USP VI. silicone hose - transparent - braid reinforcement - FDA
 USP VI. Tuyau en silicone transparent avec filet intérieur
 USP VI. - Manguera de silicona transparente con malla interior - FDA
 USP VI. - Wąż silikonowy przezroczysty - z wkładką - zgodny FDA
 USP VI. - Tubo in silicone trasparente con rete interna - FDA

Seele: Platin vernetztes Silikon gemäß USP VI, Serie 75
 Druckträger: 4 Lagen, SS316L Spirale
 Betriebsdruck: siehe Tabelle
 Betriebstemperatur: - 60 °C - + 180°C
 Rollenlänge: 4m (kein Anschnitt)
 Zulassung: Normen: USP VI. FDA 21 CFR 177.2600, BfR, EC1935/2004 (A,B,C,D1), Nicht für D2 (fettige Produkte)
 Markierung: MCC Pharma Serie 75 Max 180°C DNxxx USP ClassVI FDA CFR 177 2600
 Tube: USP VI Platinum-cured silicone hose 75 Serie
 Reinforcement: 4 Ply Polyester, SS316L Wire
 Working Pressure: see data sheet
 Temperature: - 60 °C - + 180°C
 Coil Length: 4m (no short lengths available)
 Norm: USP VI, FDA 21 CFR 177.2600, BfR, EC 1935/2004 (A, B, C, D1), Not for D2 and fatty food
 Marking: MCC Pharma Serie 75 Max 180°C DNxxx USP ClassVI FDA CFR 177 2600

Part-No.	mm	mm	bar	mm	%	g/m	Price/m
USP013X5,5-75	13	24	9,5				
USP016X5,5-75	16	27	9,0				
USP019X5,5-75	19	30	8,5				
USP022X5,5-75	22	33	8,0				
USP025X5,5-75	25	36	7,5				
USP032X5,5-75	32	43	6,5				
USP038X5,5-75	38	49	6,0				
USP051X5,5-75	51	62	5,0				

Silikon Kühlerschlauch - blau

Performance silicone hose - blue







Tuyau de refroidissement en silicone - bleu

Manguera de silicona para refrigeración - azul

Wąż silikonowy do wody chłodzącej - niebieski

Tubo in silicone di raffreddamento da - blu



Part-No.	 mm	 mm	 bar	 mm	 %	 g/m	Price/m
SBSH-6-25M	6	14	5,0				
SBSH-8-25M	8	16	5,0				
SBSH-10-25M	10	18	5,0				
SBSH-13-25M	13	21	5,0				
SBSH-16-25M	16	24	5,0				
SBSH-19-25M	19	27	4,5				
SBSH-22-25M	22	31	4,5				
SBSH-25-25M	25	34	4,0				

Seele:	Silikon rot PEROXIDVERNETZT
Druckträger:	text. Druckträger
Decke:	Silikon blau
Betriebsdruck:	siehe Tabelle
Betriebstemperatur:	- 60 °C - + 180°C
Lage:	1 Lage
Rollenlänge:	25m (kein Anschnitt)
Norm::	SAE J20 R3 / UL94 V-1
Tube:	silicone red PEROXID CURED
Reinforcement:	High tensile textile fabrics
Tube:	silicone blue
Working Pressure:	see data sheet
Temperature:	- 50 °C - + 180°C
Layers:	1 Layer
Coil Length:	25m (no short lengths available)
Norm	SAE J20 R3 / UL94 V-1



Silikon Kühlerschlauch 1m - blau

Performance silicone hose - 1m - blue







Tuyau de refroidissement en silicone - 1m - bleu

Manguera de silicona para refrigeración 1m - azul

Wąż silikonowy do wody chłodzącej - 1m - niebieski

Tubo in silicone di raffreddamento da 1m - blu

Seele:	Silikon blau PEROXIDVERNETZT
Druckträger:	text. Druckträger
Decke:	Silikon blau
Betriebsdruck:	siehe Tabelle
Betriebstemperatur:	- 50 °C - + 180°C
Lage:	< 51mm 3 Lagen > 51mm 4 Lagen > 89mm 5 Lagen
Norm::	SAE J20 R1 / UL94 V-1
Tube:	silicone blue PEROXID CURED
Reinforcement:	High tensile textile fabrics
Cover:	silicone blue
Working Pressure:	see data sheet
Temperature:	- 50 °C - + 180°C
Layers:	< 51mm 3 Layers > 51mm 4 Layers > 89mm 5 Layers
Norm	SAE J20 R1 / UL94 V-1

Part-No.	 mm	 mm	 bar	 mm	 %	 g/m	Price/pcs
SBSH-6-1M	6	14	12				
SBSH-8-1M	8	16	12				
SBSH-10-1M	10	18	10				
SBSH-13-1M	13	21	10				
SBSH-16-1M	16	24	8				
SBSH-19-1M	19	27	7,5				
SBSH-22-1M	22	30	6,5				
SBSH-25-1M	25	33	6				
SBSH-28-1M	28	36	6				
SBSH-30-1M	30	38	6				
SBSH-32-1M	32	40	5				
SBSH-35-1M	35	43	5				
SBSH-38-1M	38	46	4,5				
SBSH-40-1M	40	48	4,5				
SBSH-42-1M	42	50	4				
SBSH-45-1M	45	53	4				
SBSH-48-1M	48	56	4				
SBSH-51-1M	51	61	4				
SBSH-54-1M	54	64	4				
SBSH-57-1M	57	67	4				
SBSH-60-1M	60	70	4				
SBSH-64-1M	64	74	4				
SBSH-70-1M	70	80	4				
SBSH-76-1M	76	86	4				

Silikon Kühlerschlauch 1m - blau

Performance silicone hose - 1m - blue

Tuyau de refroidissement en silicone - 1m - bleu

Manguera de silicona para refrigeración 1m - azul

Wąż silikonowy do wody chłodzącej - 1m - niebieski

Tubo in silicone di raffreddamento da 1 m - blu



Part-No.	 mm	 mm	 bar	 mm	 %	 g/m	Price/pcs
SBSH-80-1M	80	90	4				
SBSH-83-1M	83	93	4				
SBSH-89-1M	89	99	4				
SBSH-102-1M	102	112	4				
SBSH-114-1M	114	124	4				
SBSH-127-1M	127	137	4				
SBSH-130-1M	130	140	4				
SBSH-152-1M	152	162	4				

Seele:	Silikon blau PEROXIDVERNETZT
Druckträger:	text. Druckträger
Decke:	Silikon blau
Betriebsdruck:	siehe Tabelle
Betriebstemperatur:	- 50 °C - + 180°C
Lage:	< 51mm 3 Lagen > 51mm 4 Lagen > 89mm 5 Lagen
Norm::	SAE J20 R1 / UL94 V-1
Tube:	silicone blue PEROXID CURED
Reinforcement:	High tensile textile fabrics
Cover:	silicone blue
Working Pressure:	see data sheet
Temperature:	- 50 °C - + 180°C
Layers:	< 51mm 3 Layers > 51mm 4 Layers > 89mm 5 Layers
Norm	SAE J20 R1 / UL94 V-1

Silikon Kühlerschlauch Reduzierung - blau

Performance silicone hose - reducer - blue







Réducteur pour tuyau de refroidissement en silicone - bleu

Reductor de silicona para refrigeración - azul

Wąż silikonowy do wody chłodzącej - łącznik redukcyjny - niebieski

Riduttore per tubo flessibile in silicone di raffreddamento - blu



Part-No.	 mm	 mm	 mm	 mm	 %	 kg/pcs	Price/pcs
SBSH-1316	13		16				
SBSH-2535	25		35				
SBSH-2544	25		44				
SBSH-2832	28		32				
SBSH-2835	28		35				
SBSH-3245	32		45				
SBSH-3538	35		38				
SBSH-3545	35		45				
SBSH-5060	50		60				
SBSH-5070	50		70				
SBSH-5176	51		76				
SBSH-6065	60		65				
SBSH-6376	63		76				

Seele:	Silikon blau PEROXIDVERNETZT
Druckträger:	text. Druckträger
Decke:	Silikon blau
Betriebsdruck:	siehe Tabelle
Betriebstemperatur:	- 50 °C - + 180°C
Lage:	< 51mm 3 Lagen > 51mm 4 Lagen
Norm::	SAE J20 R1 / UL94 V-1
Tube:	silicone blue PEROXID CURED
Reinforcement:	High tensile textile fabrics
Cover:	silicone blue
Working Pressure:	see data sheet
Temperature:	- 50 °C - + 180°C
Layers:	< 51mm 3 Layers > 51mm 4 Layers
Norm	SAE J20 R1 / UL94 V-1



Silikon Kühlerschlauch mit Balg - blau

Performance silicone hose - bellow - blue

Tuyau soufflet en silicone - bleu

Manguera de silicona - Fuelle - Azul

Wąż silikonowy do wody chłodzącej - Łącznik antywibracyjny - niebieski

Tubo in silicone - Soffietto - Blu

Seele:	Silikon blau PEROXIDVERNETZT
Druckträger:	text. Druckträger
Decke:	Silikon blau
Betriebsdruck:	siehe Tabelle
Betriebstemperatur:	- 50 °C - + 180°C
Lage:	< 51mm 3 Lagen > 51mm 4 Lagen
Norm::	SAE J20 R1 / UL94 V-1
Tube:	silicone blue PEROXID CURED
Reinforcement:	High tensile textile fabrics
Cover:	silicone blue
Working Pressure:	see data sheet
Temperature:	- 50 °C - + 180°C
Layers:	< 51mm 3 Layers > 51mm 4 Layers
Norm	SAE J20 R1 / UL94 V-1

Part-No.	 mm	 mm	 bar	 mm	 %	 kg/pcs	Price/pcs
SBSH-42-BELLOW	42		4,5				
SBSH-48-BELLOW	48		4				
SBSH-51-BELLOW	51		4				
SBSH-57-BELLOW	57		4				
SBSH-60-BELLOW	60		3,5				
SBSH-63-BELLOW	63		3,5				
SBSH-70-BELLOW	70		3,5				
SBSH-76-BELLOW	76		3				
SBSH-89-BELLOW	89		2,5				
SBSH-102-BELLOW	102		1				
SBSH-114-BELLOW	114		1				
SBSH-139-BELLOW	139		1				

Silikon Kühlerschlauch 45° - blau

Performance silicone hose - 45° elbow - blue







Tuyau de refroidissement en silicone avec coude 45° - bleu

Codo 45° de silicona para refrigeración

Wąż silikonowy do wody chłodzącej - Kolano 45° Stopni - niebieski

Curva di raffreddamento in silicone a 45°



Part-No.	 mm	 mm	 bar	 mm	 %	 kg/pcs	Price/pcs
SBSH-6-45	6		12				
SBSH-8-45	8		12				
SBSH-10-45	10		10				
SBSH-13-45	13		10				
SBSH-16-45	16		8				
SBSH-19-45	19		7,5				
SBSH-22-45	22		6,5				
SBSH-25-45	25		6				
SBSH-28-45	28		6				
SBSH-30-45	30		6				
SBSH-32-45	32		5				
SBSH-35-45	35		5				
SBSH-38-45	38		4,5				
SBSH-40-45	40		4,5				
SBSH-45-45	45		4				
SBSH-48-45	48		4				
SBSH-51-45	51		4				
SBSH-54-45	54		4				
SBSH-57-45	57		4				
SBSH-60-45	60		4				
SBSH-64-45	64		4				
SBSH-70-45	70		4				
SBSH-76-45	76		4				
SBSH-80-45	80		4				
SBSH-83-45	83		4				
SBSH-89-45	89		4				
SBSH-102-45	102		4				

Seele:	Silikon blau PEROXIDVERNETZT
Druckträger:	text. Druckträger
Decke:	Silikon blau
Betriebsdruck:	siehe Tabelle
Betriebstemperatur:	- 60 °C - + 180°C
Schenkelmaß:	152 mm 45° Winkel
Lage:	< 51mm 3 Lagen > 51mm 4 Lagen > 89mm 5 Lagen
Norm:	SAE J20 R1 / UL94 V-1
Tube:	silicone blue PEROXID CURED
Reinforcement:	High tensile textile fabrics
Cover:	silicone blue
Working Pressure:	see data sheet
Temperature:	- 60 °C - + 180°C
Long Legs:	152mm 45° elbow
Layers:	< 51mm 3 Layers > 51mm 4 Layers > 89mm 5 Layers
Norm	SAE J20 R1 / UL94 V-1



Silikon Kühlerschlauch 45° - blau

Performance silicone hose - 45° elbow - blue

Tuyau de refroidissement en silicone avec coude 45° - bleu

Codo 45° de silicona para refrigeración

Wąż silikonowy do wody chłodzącej - Kolano 45° Stopni - niebieski

Curva di raffreddamento in silicone a 45°

Seele:	Silikon blau PEROXIDVERNETZT
Druckträger:	text. Druckträger
Decke:	Silikon blau
Betriebsdruck:	siehe Tabelle
Betriebstemperatur:	- 60 °C - + 180°C
Schenkelmaß:	200 mm 45° Winkel
Lage:	< 51mm 3 Lagen > 51mm 4 Lagen > 89mm 5 Lagen
Norm.:	SAE J20 R1 / UL94 V-1
Tube:	silicone blue PEROXID CURED
Reinforcement:	High tensile textile fabrics
Cover:	silicone blue
Working Pressure:	see data sheet
Temperature:	- 60 °C - + 180°C
Long Legs:	200mm 45° elbow
Layers:	< 51mm 3 Layers > 51mm 4 Layers > 89mm 5 Layers
Norm	SAE J20 R1 / UL94 V-1

Part-No.	 mm	 mm	 bar	 mm	 %	 kg/pcs	Price/pcs
SBSH-8-45/200	8		12				
SBSH-10-45/200	10		10				
SBSH-12-45/200	12		10				
SBSH-14-45/200	14		8				
SBSH-15-45/200	15		8				
SBSH-16-45/200	16		8				
SBSH-19-45/200	19		7,5				
SBSH-20-45/200	20		6,5				
SBSH-22-45/200	22		6,5				
SBSH-25-45/200	25		6				
SBSH-28-45/200	28		6				
SBSH-30-45/200	30		6				
SBSH-32-45/200	32		5				
SBSH-35-45/200	35		5				
SBSH-38-45/200	38		4,5				
SBSH-40-45/200	40		4,5				
SBSH-42-45/200	42		4				
SBSH-45-45/200	45		4				
SBSH-51-45/200	51		4				
SBSH-55-45/200	55		4				
SBSH-57-45/200	57		4				
SBSH-60-45/200	60		4				
SBSH-64-45/200	64		4				
SBSH-70-45/200	70		4				
SBSH-76-45/200	76		4				
SBSH-80-45/200	80		4				
SBSH-83-45/200	83		4				
SBSH-85-45/200	85		4				
SBSH-89-45/200	89		4				
SBSH-95-45/200	95		4				
SBSH-102-45/200	102		4				

Silikon Kühlerschlauch 45° - Reduzierung - blau

Performance silicone hose - 45° elbow - reducer - blue

Tuyau réducteur en silicone avec coude 45° - bleu

Codo reductor 45° de silicona para refrigeración

Wąż silikonowy do wody chłodzącej - Kolano redukcyjne 45° - niebieski

Curva riduttore in silicone a 45° per il raffreddamento



Part-No.	1 mm		2 mm		%	kg/pcs	Price/pcs
	1 mm	1 mm	2 mm	2 mm			
SBSH-5055-45	50		55				
SBSH-5070-45	50		70				
SBSH-5157-45	51		57				
SBSH-5160-45	51		60				
SBSH-5763-45	57		63				

Seele:	Silikon blau PEROXIDVERNETZT
Druckträger:	text. Druckträger
Decke:	Silikon blau
Betriebsdruck:	siehe Tabelle
Betriebstemperatur:	- 60 °C - + 180°C
Schenkelmaß:	150 mm 45° Winkel
Lage:	< 51mm 3 Lagen > 51mm 4 Lagen
Norm::	SAE J20 R1 / UL94 V-1
Tube:	silicone blue PEROXID CURED
Reinforcement:	High tensile textile fabrics
Cover:	silicone blue
Working Pressure:	see data sheet
Temperature:	- 60 °C - + 180°C
Long Legs:	150mm 45° elbow
Layers:	< 51mm 3 Layers > 51mm 4 Layers
Norm	SAE J20 R1 / UL94 V-1

Silikon Kühlerschlauch 90° - Reduzierung - blau

Performance silicone hose - 90° elbow - reducer - blue

Tuyau réducteur en silicone avec coude 90° - bleu

Codo reductor 90° de silicona para refrigeración

Wąż silikonowy do wody chłodzącej - Kolano redukcyjne 90° - niebieski

Curva riduttore in silicone a 90° per il raffreddamento



Part-No.	1 mm		2 mm		%	kg/pcs	Price/pcs
	1 mm	1 mm	2 mm	2 mm			
SBSH-1316-90	13		16				
SBSH-1319-90	13		19				
SBSH-2835-90	28		35				
SBSH-3245-90	32		45				
SBSH-3540-90	35		40				
SBSH-3851-90	38		51				
SBSH-4551-90	45		51				
SBSH-5070-90	50		70				
SBSH-5154-90	51		54				
SBSH-5160-90	51		60				
SBSH-6351-90	63		51				
SBSH-8090-90	80		90				

Seele:	Silikon blau PEROXIDVERNETZT
Druckträger:	text. Druckträger
Decke:	Silikon blau
Betriebsdruck:	siehe Tabelle
Betriebstemperatur:	- 60 °C - + 180°C
Schenkelmaß:	152 mm 90° Winkel
Lage:	< 51mm 3 Lagen > 51mm 4 Lagen > 89mm 5 Lagen
Norm::	SAE J20 R1 / UL94 V-1
Tube:	silicone blue PEROXID CURED
Reinforcement:	High tensile textile fabrics
Cover:	silicone blue
Working Pressure:	see data sheet
Temperature:	- 60 °C - + 180°C
Long Legs:	152mm 90° elbow
Layers:	< 51mm 3 Layers > 51mm 4 Layers > 89mm 5 Layers
Norm	SAE J20 R1 / UL94 V-1



Silikon Kühlerschlauch 90° - blau

Performance silicone hose - 90° elbow - blue







Tuyau de refroidissement en silicone avec coude 90° - bleu

Codo 90° de silicona para refrigeración

Wąż silikonowy do wody chłodzącej - Kolano 90° Stopni - niebieski

Curva di raffreddamento in silicone a 90°

Seele:	Silikon blau PEROXIDVERNETZT
Druckträger:	text. Druckträger
Decke:	Silikon blau
Betriebsdruck:	siehe Tabelle
Betriebstemperatur:	- 60 °C - + 180°C
Schenkelmaß:	152 mm 90° Winkel
Lage:	< 51mm 3 Lagen > 51mm 4 Lagen > 89mm 5 Lagen
Norm::	SAE J20 R1 / UL94 V-1
Tube:	silicone blue PEROXID CURED
Reinforcement:	High tensile textile fabrics
Cover:	silicone blue
Working Pressure:	see data sheet
Temperature:	- 60 °C - + 180°C
Long Legs:	152mm 90° elbow
Layers:	< 51mm 3 Layers > 51mm 4 Layers > 89mm 5 Layers
Norm	SAE J20 R1 / UL94 V-1

Part-No.	 mm	 mm	 bar	 mm	 %	 kg/pcs	Price/pcs
SBSH-6-90	6		12				
SBSH-8-90	8		12				
SBSH-10-90	10		10				
SBSH-13-90	13		10				
SBSH-16-90	16		8				
SBSH-19-90	19		7,5				
SBSH-22-90	22		6,5				
SBSH-25-90	25		6				
SBSH-28-90	28		6				
SBSH-30-90	30		6				
SBSH-32-90	32		5				
SBSH-35-90	35		5				
SBSH-38-90	38		4,5				
SBSH-40-90	40		4,5				
SBSH-45-90	45		4				
SBSH-48-90	48		4				
SBSH-51-90	51		4				
SBSH-54-90	54		4				
SBSH-57-90	57		4				
SBSH-60-90	60		4				
SBSH-64-90	64		4				
SBSH-70-90	70		4				
SBSH-76-90	76		4				
SBSH-80-90	80		4				
SBSH-83-90	83		4				
SBSH-89-90	89		4				
SBSH-102-90	102		4				
SBSH-114-90	114		4				

Silikon Kühlerschlauch 90° - blau

Performance silicone hose - 90° elbow - blue

Tuyau de refroidissement en silicone avec coude 90° - bleu

Codo 90° de silicona para refrigeración

Wąż silikonowy do wody chłodzącej - Kolano 90° Stopni - niebieski

Curva di raffreddamento in silicone a 90°



Part-No.	 mm	 mm	 bar	 mm	 %	 kg/pcs	Price/pcs
SBSH-8-90/200	8		12				
SBSH-10-90/200	10		10				
SBSH-12-90/200	12		10				
SBSH-14-90/200	14		8				
SBSH-15-90/200	15		8				
SBSH-16-90/200	16		8				
SBSH-19-90/200	19		7,5				
SBSH-20-90/200	20		6,5				
SBSH-22-90/200	22		6,5				
SBSH-25-90/200	25		6				
SBSH-28-90/200	28		6				
SBSH-30-90/200	30		6				
SBSH-32-90/200	32		5				
SBSH-35-90/200	35		5				
SBSH-38-90/200	38		4,5				
SBSH-40-90/200	40		4,5				
SBSH-42-90/200	42		4				
SBSH-45-90/200	45		4				
SBSH-51-90/200	51		4				
SBSH-55-90/200	55		4				
SBSH-57-90/200	57		4				
SBSH-60-90/200	60		4				
SBSH-64-90/200	64		4				
SBSH-70-90/200	70		4				
SBSH-76-90/200	76		4				
SBSH-80-90/200	80		4				
SBSH-83-90/200	83		4				
SBSH-85-90/200	85		4				
SBSH-89-90/200	89		4				
SBSH-95-90/200	95		4				
SBSH-102-90/200	102		4				

Seele:	Silikon blau PEROXIDVERNETZT
Druckträger:	text. Druckträger
Decke:	Silikon blau
Betriebsdruck:	siehe Tabelle
Betriebstemperatur:	- 60 °C - + 180°C
Schenkelmaß:	200 mm 90° Winkel
Lage:	< 51mm 3 Lagen > 51mm 4 Lagen > 89mm 5 Lagen
Norm:	SAE J20 R1 / UL94 V-1
Tube:	silicone blue PEROXID CURED
Reinforcement:	High tensile textile fabrics
Cover:	silicone blue
Working Pressure:	see data sheet
Temperature:	- 60 °C - + 180°C
Long Legs:	200mm 90° elbow
Layers:	< 51mm 3 Layers > 51mm 4 Layers > 89mm 5 Layers
Norm	SAE J20 R1 / UL94 V-1



Silikon Kühlerschlauch 180° - blau

Performance silicone hose - 180° elbow - blue





Tuyau de refroidissement en silicone avec coude 180° - bleu

Codo 180° de silicona para refrigeración

Wąż silikonowy do wody chłodzącej - Kolano 180° Stopni - niebieski

Curva di raffreddamento in silicone a 180°

Seele:	Silikon blau PEROXIDVERNETZT
Druckträger:	text. Druckträger
Decke:	Silikon blau
Betriebsdruck:	siehe Tabelle
Betriebstemperatur:	- 60 °C - + 180°C
Schenkelmaß:	100 mm 180° Winkel
Norm:	SAE J20 R1 / UL94 V-1
Tube:	silicone blue PEROXID CURED
Reinforcement:	High tensile textile fabrics
Cover:	silicone blue
Working Pressure:	see data sheet
Temperature:	- 60 °C - + 180°C
Long Legs:	100mm 180° elbow
Norm	SAE J20 R1 / UL94 V-1

Part-No.	 mm	 mm	 bar	CL mm	LL mm	 kg/pcs	Price/pcs
SBSH-10-180	10			44	100		
SBSH-16-180	16			46	100		
SBSH-19-180	19			51	100		
SBSH-22-180	22			112	100		
SBSH-25-180	25			99	100		
SBSH-28-180	28			112	100		
SBSH-32-180	32			62	100		
SBSH-38-180	38			109	100		
SBSH-51-180	51			100	100		
SBSH-54-180	54			109	100		
SBSH-57-180	57			112	100		
SBSH-60-180	60			122	100		
SBSH-64-180	64			151	100		



Silikon Turboladerschlauch - rot

Silicone intercooler / turbocharge - red





Tuyau en silicone avec compresseur - Turbocompresseur

Manguera de silicona sobrealimentador / Turbosobrealimentador - rojo

Wąż silikonowy intercooler - czerwony

Tube flessibile in silicone per compressore / turbocompressore - Rosso

Seele:	Silikon blau PEROXIDVERNETZT
Druckträger:	text. Druckträger
Decke:	Silikon Rot mit Stahl Stützring
Betriebstemperatur:	- 50 °C - + 220°C
Tube:	silicone blue PEROXID CURED
Reinforcement:	High tensile textile fabrics
Tube:	silicone Red with Steel wire ring
Temperature:	- 50 °C - + 220°C

Part-No.	 mm	Length mm	 bar	 mm	 %	 kg/pcs	Price/pcs
SBSH-34-IC	34	160	4	44	100		
SBSH-38-IC	38	160	4	46	100		
SBSH-42-IC	42	160	4	51	100		
SBSH-48-IC	48	160	4	112	100		
SBSH-54-IC	54	160	4	99	100		
SBSH-60-IC	60	200	4	112	100		
SBSH-70-IC	70	200	4	62	100		
SBSH-76-IC	76	200	4	109	100		
SBSH-89-IC	89	200	4	100	100		

Silikon Kühlerschlauch T-Stück - blau

Performance silicone hose - T-piece - blue







Tuyau de refroidissement en silicone - T - bleu

Manguito de silicona en "T" para refrigeración - azul

Wąż silikonowy do wody chłodzącej - Trójnik- niebieski

Tubo flessibile in silicone T per raffreddamento - Blu



Part-No.	 mm	 mm	 bar	 mm	 %	 kg/pcs	Price/pcs
SBSH-38-T25	38	46	4,5				
SBSH-51-T25	51	61	4				
SBSH-76-T25	76	86	4				

Seele:	Silikon blau PEROXIDVERNETZT
Druckträger:	text. Druckträger
Decke:	Silikon blau
Tülle ID:	25mm
Tüllenlänge:	50mm
Betriebstemperatur:	- 60 °C - + 180°C
Länge:	100mm

Tube:	silicone blue PEROXID CURED
Reinforcement:	High tensile textile fabrics
Cover:	silicone blue
Spout ID:	25mm
Spout Length:	50mm
Temperature:	- 60 °C - + 180°C
Length:	100 mm

Flexibler Silikon Kühlerschlauch außen gewellt - 5m - blau

Flexible Performance silicone hose - 5m - blue

Tuyau flexible en silicone - 5m - bleu

Manguera corrugada flexible de silicona - 5m - azul

Wąż elastyczny silikonowy do wody chłodzącej - 5m - niebieski

Tubo flessibile ondulato in silicona - 5m - blu



Part-No.	 mm	 mm	 bar	 mm	 %	 kg/pcs	Price/pcs
SBSH-13-5M-F	13	21	3				
SBSH-16-5M-F	16	24	3				
SBSH-19-5M-F	19	27	3				
SBSH-22-5M-F	22	30	3				
SBSH-25-5M-F	25	33	3				
SBSH-28-5M-F	28	36	3				
SBSH-30-5M-F	30	38	3				
SBSH-32-5M-F	32	40	3				
SBSH-35-5M-F	35	43	3				
SBSH-38-5M-F	38	46	3				

Seele:	Silikon blau PEROXIDVERNETZT
Druckträger:	text. Druckträger
Decke:	Silikon blau, Draht verstärkt
Betriebstemperatur:	- 60 °C - + 180°C
Lagen:	3 Lagen
Länge:	5m

Tube:	silicone blue PEROXID CURED
Reinforcement:	High tensile textile fabrics
Cover:	silicone blue, wire reinforced
Temperature:	- 60 °C - + 180°C
Layers:	3 Layers
Length:	5m



350mm

Flexibler Silikon Kühlerschlauch mit glatten Enden - blau

Flexible performance silicone hose with smooth ends - blue







Tuyau flexible en silicone - embouts lisses - bleu

Manguera corrugada abocardada flexible de silicona - azul

Wąż elastyczny silikonowy do wody chłodzącej - gładki - niebieski

Tubo flessibile ondulato in silicone con estremità lisce - blu

Seele:	Silikon blau PEROXIDVERNETZT
Druckträger:	text. Druckträger
Decke:	Silikon blau, Draht verstärkt
Betriebstemperatur:	- 60 °C - + 180°C
Lagen:	2 Schlauch / 4 Schlauchende
Länge:	350mm
Tube:	silicone blue PEROXID CURED
Reinforcement:	High tensile textile fabrics
Cover:	silicone blue, wire reinforced
Temperature:	- 60 °C - + 180°C
Layers:	2 Hose / 4 Hose end
Length:	350mm

Part-No.	 mm	 mm	 bar	 mm	 %	 kg/pcs	Price/pcs
SBSH-13-F350SM	13	23	1,5	60			
SBSH-15-F350SM	15	25	1,5	65			
SBSH-20-F350SM	20	30	1,5	70			
SBSH-22-F350SM	22	32	1,5	95			
SBSH-25-F350SM	25	35	1,5	100			
SBSH-28-F350SM	28	38	1,5	105			
SBSH-30-F350SM	30	40	1,5	110			
SBSH-35-F350SM	35	45	1,5	115			
SBSH-38-F350SM	38	48	1,5	130			
SBSH-40-F350SM	40	50	1,5	145			
SBSH-45-F350SM	45	55	1,5	160			
SBSH-50-F350SM	50	60	1,5	200			
SBSH-57-F350SM	57	67	1,5	230			
SBSH-60-F350SM	60	70	1,5	250			
SBSH-65-F350SM	65	75	1,5	270			
SBSH-70-F350SM	70	80	1,5	350			

Flexibler Silikon Kühlerschlauch mit glatten Enden - blau

Flexible performance silicone hose with smooth ends - blue

Tuyau flexible en silicone - embouts lisses - bleu







Manguera corrugada abocardada flexible de silicona - azul

Wąż elastyczny silikonowy do wody chłodzącej - gładki - niebieski

Tubo flessibile ondulato in silicone con estremità lisce - blu



500mm

Part-No.	 mm	 mm	 bar	 mm	 %	 kg/pcs	Price/pcs
SBSH-13-F500SM	13	23	1,5	60			
SBSH-15-F500SM	15	25	1,5	65			
SBSH-20-F500SM	20	30	1,5	70			
SBSH-22-F500SM	22	32	1,5	95			
SBSH-25-F500SM	25	35	1,5	100			
SBSH-28-F500SM	28	38	1,5	105			
SBSH-30-F500SM	30	40	1,5	110			
SBSH-35-F500SM	35	45	1,5	115			
SBSH-38-F500SM	38	48	1,5	130			
SBSH-40-F500SM	40	50	1,5	145			
SBSH-45-F500SM	45	55	1,5	160			
SBSH-50-F500SM	50	60	1,5	200			
SBSH-57-F500SM	57	67	1,5	230			
SBSH-60-F500SM	60	70	1,5	250			
SBSH-65-F500SM	65	75	1,5	270			
SBSH-70-F500SM	70	80	1,5	350			

Seele:	Silikon blau PEROXIDVERNETZT
Druckträger:	text. Druckträger
Decke:	Silikon blau, Draht verstärkt
Betriebstemperatur:	- 60 °C - + 180°C
Lagen:	2 Schlauch / 4 Schlauchende
Länge:	500mm
Tube:	silicone blue PEROXID CURED
Reinforcement:	High tensile textile fabrics
Cover:	silicone blue, wire reinforced
Temperature:	- 60 °C - + 180°C
Layers:	2 Hose / 4 Hose end
Length:	500mm



750mm

Flexibler Silikon Kühlerschlauch mit glatten Enden - blau

Flexible performance silicone hose with smooth ends - blue







Tuyau flexible en silicone - embouts lisses - bleu

Manguera corrugada abocardada flexible de silicona - azul

Wąż elastyczny silikonowy do wody chłodzącej - gładki - niebieski

Tubo flessibile ondulato in silicone con estremità lisce - blu

Seele:	Silikon blau PEROXIDVERNETZT
Druckträger:	text. Druckträger
Decke:	Silikon blau, Draht verstärkt
Betriebstemperatur:	- 60 °C - + 180°C
Lagen:	2 Schlauch / 4 Schlauchende
Länge:	750mm
Tube:	silicone blue PEROXID CURED
Reinforcement:	High tensile textile fabrics
Cover:	silicone blue, wire reinforced
Temperature:	- 60 °C - + 180°C
Layers:	2 Hose / 4 Hose end
Length:	750mm

Part-No.	 mm	 mm	 bar	 mm	 %	 kg/pcs	Price/pcs
SBSH-13-F750SM	13	23	1,5	60			
SBSH-15-F750SM	15	25	1,5	65			
SBSH-20-F750SM	20	30	1,5	70			
SBSH-22-F750SM	22	32	1,5	95			
SBSH-25-F750SM	25	35	1,5	100			
SBSH-28-F750SM	28	38	1,5	105			
SBSH-30-F750SM	30	40	1,5	110			
SBSH-35-F750SM	35	45	1,5	115			
SBSH-38-F750SM	38	48	1,5	130			
SBSH-40-F750SM	40	50	1,5	145			
SBSH-45-F750SM	45	55	1,5	160			
SBSH-50-F750SM	50	60	1,5	200			
SBSH-57-F750SM	57	67	1,5	230			
SBSH-60-F750SM	60	70	1,5	250			
SBSH-65-F750SM	65	75	1,5	270			
SBSH-70-F750SM	70	80	1,5	350			

Flexibler Silikon Kühlerschlauch mit glatten Enden - blau

Flexible performance silicone hose with smooth ends - blue

Tuyau flexible en silicone - embouts lisses - bleu







Manguera corrugada abocardada flexible de silicona - azul

Wąż elastyczny silikonowy do wody chłodzącej - gładki - niebieski

Tubo flessibile ondulato in silicone con estremità lisce - blu



1000mm

Part-No.	 mm	 mm	 bar	 mm	 %	 kg/pcs	Price/pcs
SBSH-13-F1000SM	13	23	1,5	60			
SBSH-15-F1000SM	15	25	1,5	65			
SBSH-20-F1000SM	20	30	1,5	70			
SBSH-22-F1000SM	22	32	1,5	95			
SBSH-25-F1000SM	25	35	1,5	100			
SBSH-28-F1000SM	28	38	1,5	105			
SBSH-30-F1000SM	30	40	1,5	110			
SBSH-35-F1000SM	35	45	1,5	115			
SBSH-38-F1000SM	38	48	1,5	130			
SBSH-40-F1000SM	40	50	1,5	145			
SBSH-45-F1000SM	45	55	1,5	160			
SBSH-50-F1000SM	50	60	1,5	200			
SBSH-57-F1000SM	57	67	1,5	230			
SBSH-60-F1000SM	60	70	1,5	250			
SBSH-65-F1000SM	65	75	1,5	270			
SBSH-70-F1000SM	70	80	1,5	350			

Seele:	Silikon blau PEROXIDVERNETZT
Druckträger:	text. Druckträger
Decke:	Silikon blau, Draht verstärkt
Betriebstemperatur:	- 60 °C - + 180°C
Lagen:	2 Schlauch / 4 Schlauchende
Länge:	1000mm
Tube:	silicone blue PEROXID CURED
Reinforcement:	High tensile textile fabrics
Cover:	silicone blue, wire reinforced
Temperature:	- 60 °C - + 180°C
Layers:	2 Hose / 4 Hose end
Length:	1000mm

WEITERE AUSFÜHRUNGEN

Silikonschlauch



SONDERANFERTIGUNGEN

Rahmen der kontinuierlichen Erweiterung des Silikonschlauchprogramms wird MCC weitere Varianten mit und ohne Gewebeeinlagen in das Lieferprogramm aufnehmen. Sonderlängen, spezielle Maße und Ausführungen sind nach Absprache ebenfalls kurzfristig lieferbar.



90°/45° Elbow Coolant Hose

Cold side & hot side



Customer Design



CAC Hose

Hot Side



Customer Design



CAC Hose

Cold Side



Vacuum Hose

Standard-Colour: black/blue/red

SILIKONSCHLÄUCHE



MORE VERSIONS

Silicon hoses

CUSTOMISED PRODUCTS

As part of our expansion of silicone hoses, we are adding more options to our range, including hoses with and without reinforcement. Customized designs, lengths, and other specifications are available upon request.



T-Piece

Multiple combinations are possible



Single Hump

Any ID is available from 6 to 152mm



Elbows

45° / 90° 135° / 180 °
Different lengths possible



Silicone Screw Couplings

Various possibilities: with BSP female thread or DIN clamp



Elbows - Reducer

45° / 90° 135° / 180 °
Different lengths possible



Straight Reducer

Any ID is available from 6 to 152mm



ARBEITSSCHUTZ PRODUKTE

Gehörschutz	474
Kopfschutz	475
Augenschutz	476
Gesichtsschutz	479



Gehörschutzstöpsel mit Band

Banded ear plugs
 Bouchons d'oreilles avec arceau
 Tapones para los oídos con banda
 Zatycka wielokrotnego użytku ze sznurkiem
 Tappi di protezione dell'udito con banda

Part-No.	Colour	CE	Price
EP505	orange	EN 352-2	

- Wiederverwendbar
- Geräuschdämmung 25dB (SNR)
- Reusable
- Noise absorption 25dB (SNR)



Gehörschutzstöpsel mit Band

Corded Ear Plugs
 Bouchons d'oreilles cordés
 Orejeras de protección
 Zatycka do uszu ze sznurkiem
 Tappi di protezione dell'udito con banda

Part-No.	Colour	CE	Price
EP33C	orange	EN 352-2	

- Wiederverwendbar
- Geräuschdämmung 25dB (SNR)
- Reusable
- Noise absorption 25dB (SNR)

Atmungsaktive Anstoßkappe

Ventilation head protection working cap

Casquette de protection antichoc

Gorra protectora antigolpes

Czapka antyskalpowa z wentylacją

Cappuccio traspirante per il bernoccolo



Part-No.	Colour	CE	Price
SM933	blue	EN 812	

- Atmungsaktive Netzstruktur für bessere Luftzirkulation
- Gepolstertes Innenleben
- Breathable mesh for better ventilation
- Internal foam pad for even more comfort

Anstoßkappe

Head protection working cap

Casquette de protection antichoc

Gorra protectora antigolpes

Czapka antyskalpowa

Tappo a urto



Part-No.	Colour	CE	Price
SM913	blue	EN 183	

- Gepolstertes Innenleben
- Internal foam pad for even more comfort



Leichte Schutzbrille

Lightweight safety glasses
 Lunettes de sécurité
 Gafas de seguridad
 Okulary ochronne wytrzymałe panoramiczne
 Occhiali protettivi leggeri

Part-No.	Colour	CE	Price
SG2629	transparent	EN166F	
SG2629B	black	EN166F	

- Leicht
- Guter Schlagschutz
- Weites Sichtfeld inklusive Seitenschutz
- 100% Polycarbonat
- Lightweight
- Excellent impact protection
- Wide field of vision and side protection with large side shields
- 100% polycarbonate



Schutzbrille mit verstellbarer Bügellänge

Safety glasses with adjustable length
 Lunettes de sécurité
 Gafas de seguridad
 Okulary ochronne, regulowana długość zauszniaka
 Occhiali di sicurezza con lunghezza delle aste regolabile

Part-No.	Colour	CE	Price
SG2612	transparent	EN166	

- Anpassbare, variable Bügellänge
- Kratzfeste Schutzgläser
- Antibeschlag Beschichtung
- Adjustable length
- Anti scratch
- Anti fog

Vollzicht-Schutzbrille für Chemie-Industrie

Anti chemical safety goggle

Lunettes de protection anti produits chimiques

Gafas de seguridad de protección anti productos químicos

Gogle ochronne z wentylacją, które chronią przed chemikaliami

Occhiali di sicurezza a visione completa per l'industria chimica



Part-No.	Colour	CE	Price
SG204	transparent	EN 166B	

- Indirekte Belüftung an Ober- und Unterseite
- Geeignet für den Einsatz in der chemischen Industrie
- Schlagfest
- Indirect vents on the bottom and top
- Anti-chemical
- Anti- Impact

Vollzicht-Schutzbrille

Safety goggle

Lunettes de sécurité

Gafas de seguridad

Gogle ochronne z wentylacją pośrednią

Occhiali di sicurezza a visione completa



Part-No.	Colour	CE	Price
SG212	transparent	EN166B	

- Öffnungen an der Oberseite ermöglichen optimale Belüftung
- Staubschutz
- Schlagfest
- Direct vents on the top ensure ideal ventilation
- Anti-dust
- Anti-impact



Vollzicht-Schutzbrille

Safety goggle
 Lunettes de sécurité
 Gafas de seguridad
 Gogle ochronne z wentylacją pośrednią
 Occhiali di sicurezza a visione completa

Part-No.	Colour	CE	Price
SG232	green / transparent	EN 166B	

- Integrierte indirekte Belüftung
- Spritzfest
- Integrated indirect ventilation
- Anti-Splash lenses



Überziehbrille

Safety glasses
 Lunettes de sécurité
 Gafas de seguridad
 Okulary ochronne z wentylacją boczną
 Coprire gli occhiali

Part-No.	Colour	CE	Price
SG2610	transparent	EN166	

- Über der Brille tragbar
- Kratzfeste Schutzgläser
- Antibeschlag Beschichtung
- Stirnschutz mit seitlicher Belüftung.
- Hergestellt aus 100% Polycarbonat
- Glasses fit over most prescription eyewear
- Anti-scratch & anti-fog
- Brow protection
- Side vents
- Made of 100% PC

Gesichtsschutz

Face shield
Écran facial
Máscara de protección facial
Osłona twarzy, regulowany pasek
Scudo facciale



Part-No.	Colour	CE	Price
FS801	black / transparent	EN166	

- Größenverstellbares Kopfband
- Großes Polycarbonat Visier (ca. 20cm x 34cm)
- Klappbares Visier
- adjustable headgear
- 8"x13.5" polycarbonate visor
- Flip front

Klares Ersatzvisier

Transparent visor
Visière transparente
Visera transparente
Wizjerka zapasowa, przezroczysta
Visiera di ricambio trasparente



Part-No.	Colour	CE	Price
VC85M	transparent	EN 166	

- Durchsichtiges Polycarbonat Visier
- Ca. 20cm x 39cm x1.0mm
- Clear polycarbonate visor
- 8"x15.5"x1.0mm

Getöntes Ersatzvisier

Face shield replacement face shield
Écran de rechange teinté
Visor de repuesto tintado
Wizjerka zapasowa przyciemniana
Visiera di ricambio colorata



Part-No.	Colour	CE	Price
VC85MS	black	EN166 EN 172	

- Getöntes Polycarbonat Visier
- Ca. 20cm x 39cm x1.0mm
- tinted polycarbonate visor
- 8"x15.5"x1.0mm

Allgemeine Geschäftsbedingungen der Millennium Coupling Germany GmbH

1 / Allgemeines

Die nachstehend aufgeführten Geschäftsbedingungen der Millennium Coupling Germany GmbH (Verkäufer) gelten für alle Kaufverträge vorbehaltlich einer ausdrücklichen und formellen Zustimmung des Verkäufers.

Erteilte Aufträge gelten als Zustimmung zu den nachstehend genannten Verkaufsbedingungen, die auch dann Gültigkeit haben, wenn die allgemeinen Geschäftsbedingungen des Kunden, die auf dessen Bestellschein vermerkt sind, diesen widersprechen. Die Tatsache, dass der Verkäufer, nicht ausdrücklich von seinem Recht Gebrauch macht, bedeutet nicht, dass er zu einem späteren Zeitpunkt diese Bedingungen geltend machen kann.

2 / Bestellungen

Aufträge bedürfen der schriftlichen Bestätigung des Verkäufers. Erteilte Aufträge können nur mit ausdrücklicher Zustimmung des Verkäufers geändert oder storniert werden. Eine Auftragsänderung oder Stornierung bedarf der schriftlichen Form durch Einschreiben mit Rückschein vor Warenauslieferung oder Bereitstellung der Leistung.

Wenn der Verkäufer der Auftragsstornierung zustimmt, ist dieser berechtigt, eine Ausgleichzahlung, entsprechend dem entstandenen Verlust in Rechnung zu stellen.

Die Auftragsausführung gilt mit einer bestellten Menge von +/-5% als abgeschlossen und kann je nach Lieferverfügbarkeit des Verkäufers reduziert oder storniert werden.

3 / Preise

Preise für Material in der Produktion oder im Lager des Verkäufers sind Nettopreise, zzgl. Transport und Einwegverpackung. Rechnungspreise basieren auf dem am Liefertag gültigen Listenpreis. Der Verkäufer behält sich das Recht vor, Preise ohne Vorankündigung zu ändern.

4 / Lieferung – Gewährleistung

Wenn nicht anders vereinbart, ist der Leistungsort für die Lieferung die Produktionsstätte oder das Lager des Verkäufers.

Die Lieferung erfolgt durch Bestätigung der Warenverfügbarkeit und direkte Übergabe an den Käufer, oder durch Übergabe der Ware in den Räumlichkeiten des Verkäufers an den Spediteur/Verfrachter der vom Verkäufer oder Käufer beauftragt wird.

Wenn nicht anders von beiden Parteien schriftlich vereinbart, gelten die derzeit gültigen Incoterms 2000 der Industrie- und Handelskammer für die Übernahme der Transportrisiken.

Angaben der Lieferzeiten dienen lediglich der Kenntnisnahme. Lieferverzögerungen berechtigen den Käufer nicht, Schadensersatz zu fordern, die Warenannahme zu verweigern oder den laufenden Auftrag zu stornieren. Unbeschadet der Maßnahmen, die gegenüber dem Spediteur zu ergreifen sind, ist jegliche Reklamation in Bezug auf die Liefermenge, Ausführung, Qualität oder andere Gründe dem Verkäufer durch Einschreiben mit Rückschein innerhalb einer Woche ausgehend vom Datum der Anlieferung beim Käufer mitzuteilen. Nach Ablauf dieser Frist gilt die Ware als akzeptiert.

Der Käufer ist berechtigt, selbst Maßnahmen gegen den Spediteur zu ergreifen. Der Spediteur ist innerhalb von drei (3) Tagen nach Erhalt der Ware durch schriftlichen Vermerk auf dem Transportdokument und per Einschreiben mit Rückschein davon in Kenntnis zu setzen. Der Käufer informiert den Verkäufer über diesen Sachverhalt durch Zusendung einer Kopie des Einschreibens.

Der Käufer ist verpflichtet, aufgetretene Mängel und Fehler zu begründen. Er stellt dem Verkäufer alle Mittel zur Verfügung, die zur Überprüfung und Behebung dieser Fehler und/oder Mängel erforderlich sind.

Im Fall einer anerkannten Reklamation, beschränkt sich die Haftung des Verkäufers lediglich auf das Auswechseln der defekten Teile, eine Schadensersatzzahlung wird nicht geleistet.

Der Verkäufer wird von seiner Lieferverpflichtung entbunden, wenn der Käufer die Zahlungsbedingungen nicht einhält, d. h. insbesondere:

- Keine der Rechnungen oder Zuschläge werden zum fälligen Datum beglichen.
- Das Fälligkeitsdatum für eine Voraus- oder Anzahlung wird nicht eingehalten.
- Verzögerte Lieferung, die durch den Käufer selbst veranlasst wird
- Veränderung der ursprünglichen Auftragsbedingungen
- Wenn für die Auftragsausführung weitere Ergänzungen oder technische Abstimmungen erforderlich werden, und über die der Käufer den
- Verkäufer nicht in angemessener Zeit in Kenntnis gesetzt hat
- Höhere Gewalt.

Der Verkäufer garantiert, dass die von ihm gelieferten Produkte für den vom Käufer genannten Verwendungszweck geeignet sind. Der Verkäufer übernimmt keine Haftung dafür, dass seine Produkte in Bereichen angewendet werden können, die ihm der Käufer nicht genannt hat. Der Verkäufer haftet nicht für die Verwendung seiner Produkte im Zusammenhang mit Fremdprodukten, d.h. wenn diese nicht vom Verkäufer geliefert wurden.

5 / Warenrückgabe

Jegliche Warenrückgabe bedarf der vorherigen schriftlichen Zustimmung des Verkäufers. Bei Rückgabe ohne eine solche Zustimmung kann keine Gutschrift erteilt werden. Wenn nicht anders vereinbart, gehen Frachtkosten und Risiken für eine Warenrückgabe zwecks Überprüfung und/oder Reparatur sowie die Rücksendung an den Käufer zu Lasten des Käufers.

Jede Warenrückgabe zur Überprüfung berechtigt den Verkäufer, Materialproben zu Untersuchungs- und Analyse Zwecken zu entnehmen. Im Fall einer akzeptierten Warenrückgabe, erstellt der Verkäufer eine Gutschrift zu Gunsten des Käufers.

6 / Rechnungsstellung -Begleichung

Wenn nicht anders zwischen den Parteien vereinbart, werden Lieferungen mit dreißig Tagen zum Monatsende in Rechnung gestellt und sind netto ohne Abzug per Banküberweisung zu begleichen.

Die Rechnung beinhaltet das Fälligkeitsdatum: Zahlungen erfolgen auf das Konto des Verkäufers. Bei Zahlungsverzug, gemäß der vertraglich genannten Fälligkeit, fallen Verzugszinsen für den offenstehenden Betrag an, entsprechend dem französischen Gesetz, die das dreifache des Basissatzes betragen, oder in anderen Fällen gemäß dem jeweilig geltenden nationalen Gesetz, wodurch die Einklagbarkeit der ausstehenden Forderung nicht beeinträchtigt wird.

Bei Erstaufträgen, nach Eröffnung eines Kundenkontos, ist die Rechnung vor Versand zu begleichen.

Der Verkäufer behält sich das Recht vor, eine Mindestvorauszahlung von 30% des gesamten Auftragswertes zu fordern. Die Zahlungsfälligkeiten können grundsätzlich nicht auf ein späteres Datum verlegt werden und sind in einem solchen Fall Gegenstand einer Klage. Der Verkäufer ist berechtigt, die Bedingungen der Auftragsdurchführung, auch bei bereits laufender Auftragsabwicklung, sowie Zahlungsbedingungen einer erneuten Überprüfung zu unterziehen, wenn sich die wirtschaftliche und finanzielle Situation des Käufers erheblich verändert.

Allgemeine Geschäftsbedingungen der Millennium Coupling Germany GmbH

Zahlungsverzug:

Bei Nichteinhaltung der Fälligkeit, behält sich der Verkäufer das Recht vor, alle noch nicht fälligen Rechnungen einschließlich Wechsel einzufordern.

Aussetzungs- und Rücktrittsklausel:

Gerät der Käufer mit seiner Fälligkeiten in Verzug, behält sich der Verkäufer das Recht vor, alle noch offenstehenden Aufträge auszusetzen oder zu kündigen. Bereits geleistete Teilzahlungen werden nicht erstattet.

7 / Eigentumsvorbehalt

Der Verkäufer behält das Eigentumsrecht an der Kaufsache bis zum Eingang aller Zahlungen aus der Geschäftsverbindung mit dem Käufer. Bei Nichteinhaltung einer Fälligkeit, ist der Verkäufer berechtigt, die Ware zurückzufordern. Der Käufer wird darüber vom Verkäufer per Einschreiben mit Rückschein in Kenntnis gesetzt.

Ungeachtet dieser Bestimmungen, übernimmt der Käufer nach Anlieferung sämtliche aus den Waren resultierenden Risiken. Der Käufer trägt die Versicherungskosten zur Deckung solcher Risiken und erbringt auf Verlangen des Verkäufers den entsprechenden Nachweis.

Der Verkäufer stellt sicher, dass eine Identifizierung der Produkte jederzeit möglich ist.

Noch nicht beglichene Produkte werden getrennt gelagert.

Der Käufer betreibt den Weiterverkauf der Produkte im ordentlichen Geschäftsgang und benachrichtigt den Verkäufer umgehend über getätigte Verkäufe, Namen und Adressen der Abnehmer, so dass der Verkäufer gegebenenfalls Rechtsansprüche gegenüber einer dritten Partei geltend machen kann.

Im Fall eines Sanierungs-, Insolvenzverfahrens oder Konkurs wird die Befugnis zum Weiterverkauf automatisch entzogen.

8 / Haftung

Sichtbare Mängel oder Abweichungen, die Gegenstand einer Überprüfung sind, müssen innerhalb von 24 Stunden nach Empfang der Ware per Einschreiben mit Rückschein angezeigt werden. Die Reklamation muss exakte Angaben über Art und Umfang des Mangels enthalten. Auf die gleiche Art und Weise, innerhalb der gesetzlichen Frist, handelt der Käufer im Fall einer Reklamation gegenüber dem Spediteur.

Der Verkäufer übernimmt die Haftung bis zu einem Höchstwert, der dem Gesamtwert der verkauften Ware entspricht. Der Verkäufer haftet für alle direkten Kosten, die dem Käufer infolge mangelhafter Produktlieferungen des Verkäufers entstehen.

Der Verkäufer lehnt jegliche Haftung für direkte oder indirekte Nachteile ab, die u. a. entstanden sein könnten aus: Umsatzeinbußen, Kundenrückgang, Geschäftsverlusten oder anderen Gründen.

Der Verkäufer übernimmt keine Haftung für Schäden infolge unsachgemäßer Nutzung seiner Produkte. Die vom Verkäufer vorgegebenen Bedingungen gelten für Lagerung, Handhabung Montage Nutzungsbedingungen und Wartung und müssen vom Käufer befolgt werden, der seinerseits gehalten ist, Anwender der Produkte über diese Bedingungen in Kenntnis zu setzen.

9 / Industrielles und kommerzielles Eigentum

Mit Ausnahme der Standardprodukte, hat der Käufer dafür Sorge zu tragen, dass das Produkt nicht das geistige Eigentumsrecht einer dritten Partei verletzt. Im Fall eines solchen Verstoßes sind sowohl der Verkäufer als auch der Käufer berechtigt die Produktion dieses Produktes einzustellen, ohne dass eine der beiden Parteien rechtliche Schritte gegeneinander einleiten können.

Der Käufer erwirbt keine Ansprüche auf das industrielle, geistige und kommerzielle Eigentum des Verkäufers, dies gilt insbesondere für Kataloge,

Preislisten, Werbeliteratur oder technische Datenblätter. Sie sind das alleinige Eigentum des Verkäufers.

Der Käufer nutzt sie ausschließlich zu persönlichen Zwecken oder zum Verkauf der Produkte des Verkäufers.

Wenn nicht ausdrücklich anders mit dem Verkäufer vereinbart, bietet der Käufer die Produkte ausschließlich unter dem Namen, der Referenz, der Verpackung oder Aufmachung des Verkäufers an.

Wenn nicht anders vereinbart, sind Produktionswerkzeuge, Formen und Bildmaterial Eigentum des Verkäufers, da diese nach eigenen Spezifikationen erstellt wurden, selbst wenn der Kunde sich an deren Erstellungskosten beteiligt hat. Der Verkäufer behält sich das Recht vor, Werkzeuge, Formen und Bildmaterial nicht mehr zu lagern, wenn deren letzte Verwendung drei Jahre zurückliegt.

10 / Höhere Gewalt

Umstände von höherer Gewalt entbinden den Verkäufer von seiner vertraglichen Verpflichtung.

Umstände von höherer Gewalt sind Ereignisse, die unabhängig vom Willen des Verkäufers sind und einen normalen Ablauf bei der Produktion und/oder Auslieferung der Waren verhindern.

Falls ein Umstand von höherer Gewalt den Verkäufer daran hindert, die vereinbarten Liefertermine einzuhalten, sind die vertraglich festgelegten Fristen zu verlängern, d.h. entsprechend dem Zeitverlust, der aus dem Umstand von höherer Gewalt resultiert.

Der Kunde ist nicht berechtigt, Schadensersatz oder Ansprüche gegen den Verkäufer geltend zu machen, wenn die Ursache einer solchen Verzögerung auf höhere Gewalt zurückzuführen ist.

11 / Gerichtsstand und Erfüllungsort

Gerichtsstand und Erfüllungsort jeglichen Rechtsstreits zwischen Verkäufer und Käufer ist das am Geschäftssitz des Verkäufers ansässige Handelsgericht, gleiches gilt für Regressklagen oder Streitverkündung.

Für die vertraglichen Beziehungen zwischen den Parteien gilt das Deutsche Recht.

WE DO IT UNDER PRESSURE



E-Mail: info@mcc-germany.com
Telefon: +49(0)2241/932580
Adresse: Langbaughstr. 5; 53842 Troisdorf

www.mcc-germany.com

